

INDICE CATALOGO

<u>Informazioni Generali e Tecniche</u>	<u>Schede IG</u>
	<u>Schede IT</u>
<u>Elenco numerico progressivo dei profilati di tutte le serie</u>	<u>Schede IT</u>
<u>Elenco Accessori/Attrezzature dedicate</u>	<u>Schede EA</u>
<u>Elenco Guarnizioni</u>	<u>Schede EG</u>
<u>Elenco Componenti Profilati</u>	<u>Schede CP</u>
<u>Sezioni Profilati</u>	<u>Schede SP</u>
<u>Nodi Serramenti</u>	<u>Schede NS</u>
	<u>Schede NSa</u>
<u>Schede Tecniche</u>	<u>Schede SM</u>
	<u>Schede SV</u>
	<u>Schede ST</u>
<u>Schede Lavorazioni</u>	<u>Schede SL</u>

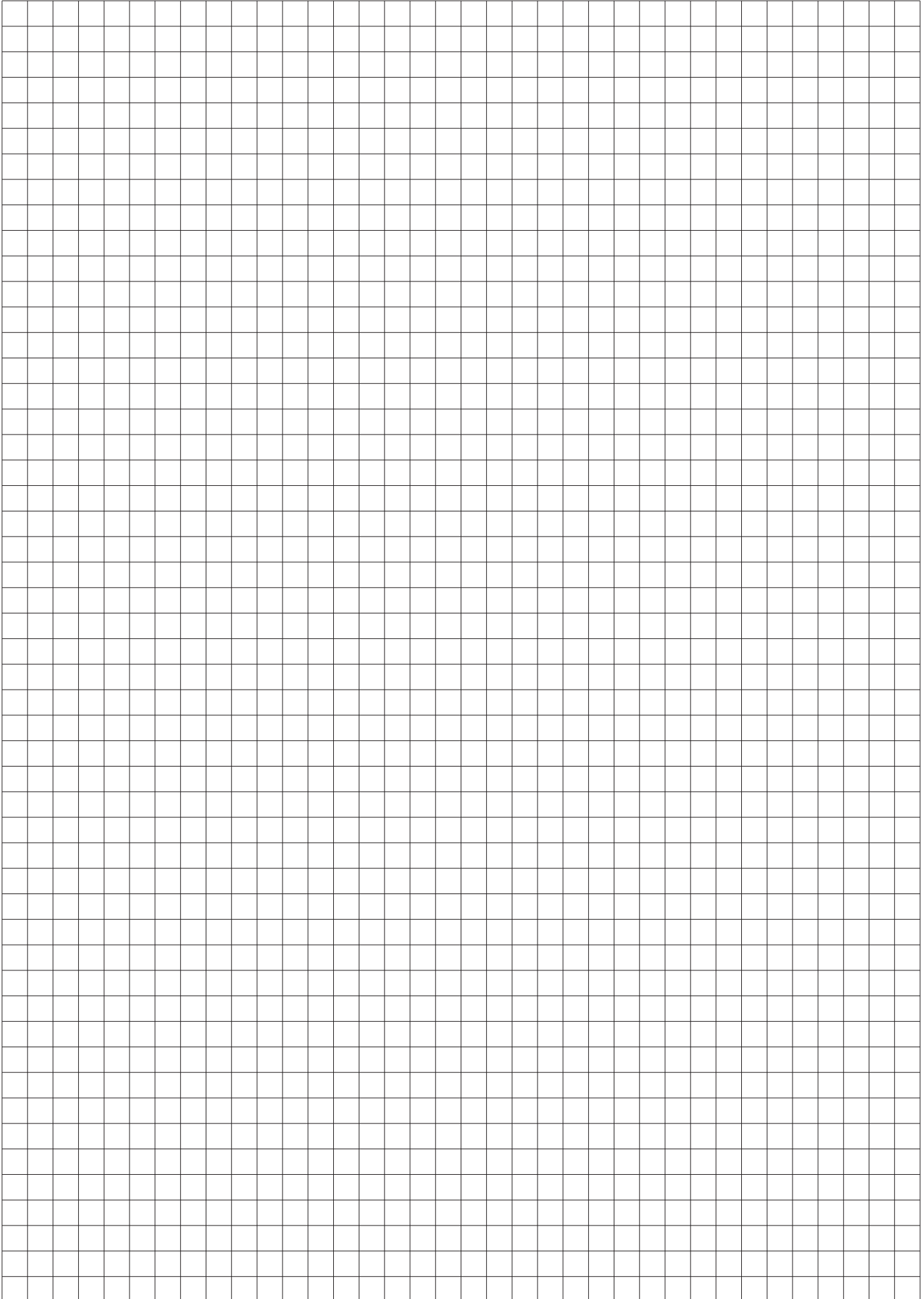

INFORMAZIONI GENERALI

- *Presentazione catalogo
ed Informazioni Generali (Schede IG)*

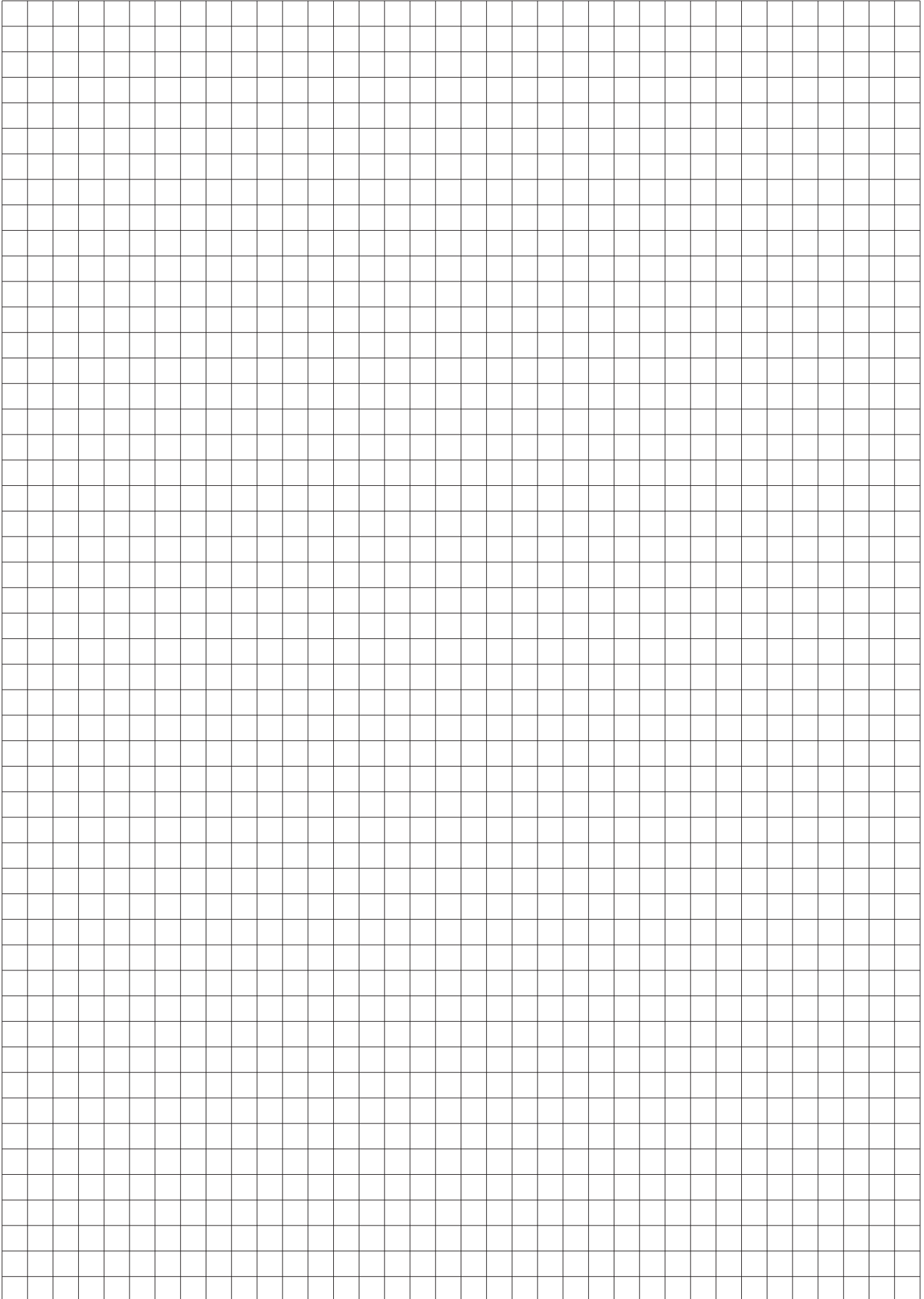

PRESENTAZIONE CATALOGO

Questo catalogo è composto da schede riconoscibili da diversi codici.

Ogni scheda svolge una precisa funzione ed utilizzandole correttamente sarà più semplice apprendere la logica del sistema.

Informazioni Generali e Tecniche

Schede IG - Schede IT

Dopo una breve presentazione del catalogo ed alcune informazioni generali (Schede IG) sono illustrati i principali concetti costruttivi e le informazioni tecniche necessarie, la descrizione tecnica e le caratteristiche termiche principali del sistema, compresi i limiti dimensionali, le certificazioni e l'elenco dei profili che compongono tutto il sistema.

Elenco Accessori/Attrezzature dedicate

Schede EA

Gli accessori sono riepilogati e disposti in ordine logico/progressivo. Alle squadrette ed ai cavallotti seguono gli accessori personalizzati o individuati ad hoc per la serie TH83 Finestre seguiti dalle attrezzature.

Per gli accessori non "dedicati" (commerciali) consultare i cataloghi fornitori.

Elenco Guarnizioni

Schede EG

Le guarnizioni sono riepilogate e disposte in ordine progressivo.

Elenco Componenti Profilati

Schede CP

I profilati di tutto il sistema sono suddivisi per soluzioni architettoniche e sono riepilogati e disposti, ove possibile, in ordine progressivo numerico.

Lo sfondo di diverso colore evidenzia i profilati corollari. La soluzione tonda comprende i profilati base e comuni a tutte le altre serie architettoniche.

Sezioni Profilati

Schede SP

Sono rappresentate le sezioni in scala 1:1 dei profilati componenti il sistema.

In alcuni casi sono stati riportati anche degli esempi di applicazioni riportando delle sezioni con nodi in scala ridotta.

Nodi Serramenti

Schede NS

Sono rappresentate le sezioni in scala 1:1 delle principali tipologie realizzabili con la serie tonda.

Sono puramente rappresentativi della tipologia ed i profilati possono essere sostituiti con quelli di pari caratteristiche a disposizione nell'elenco profilati CP.

Nodi Serramenti "Applicativi"

Schede NSa

Sono illustrati i principali attacchi a muro di possibili applicazioni di alcuni profilati. Ulteriori dettagli verranno eseguiti a richiesta.

Schede Tecniche

Schede SM - Schede SV - Schede ST

In questa sezione vengono raggruppate le schede tecniche per la realizzazione del sistema e sono suddivise in tre parti:

- **Schede SM: Schede per il Montaggio per il corretto assemblaggio**
(es: abaci squadrette e cavallotti)
- **Schede SV: Schede d'utilizzo guarnizioni e Vetrazioni e spessoramento Vetri**
- **Schede ST: Schede di Taglio**

Sono schede esemplificative che illustrano degli esempi di Schemi di taglio, distinta accessori e guarnizioni per lo sviluppo e realizzazione delle tipologie numerico.

Dalla consultazione di queste schede si ricavano informazioni utili sia al tecnico che al preventivoista.

Per tutte le informazioni sugli accessori non personalizzati consultare il catalogo del produttore.

Schede Lavorazioni

Schede SL

Sono rappresentate le lavorazioni complete di quote di esecuzione ed i codici delle macchine necessarie alla loro realizzazione.

INFORMAZIONI TECNICHE

(Schede IT)

- *Caratteristiche tecniche del sistema*
- *Prestazioni termiche del sistema*
- *Limiti Dimensionali*
- *Elenco di TUTTI I PROFILATI della serie in ordine numerico*

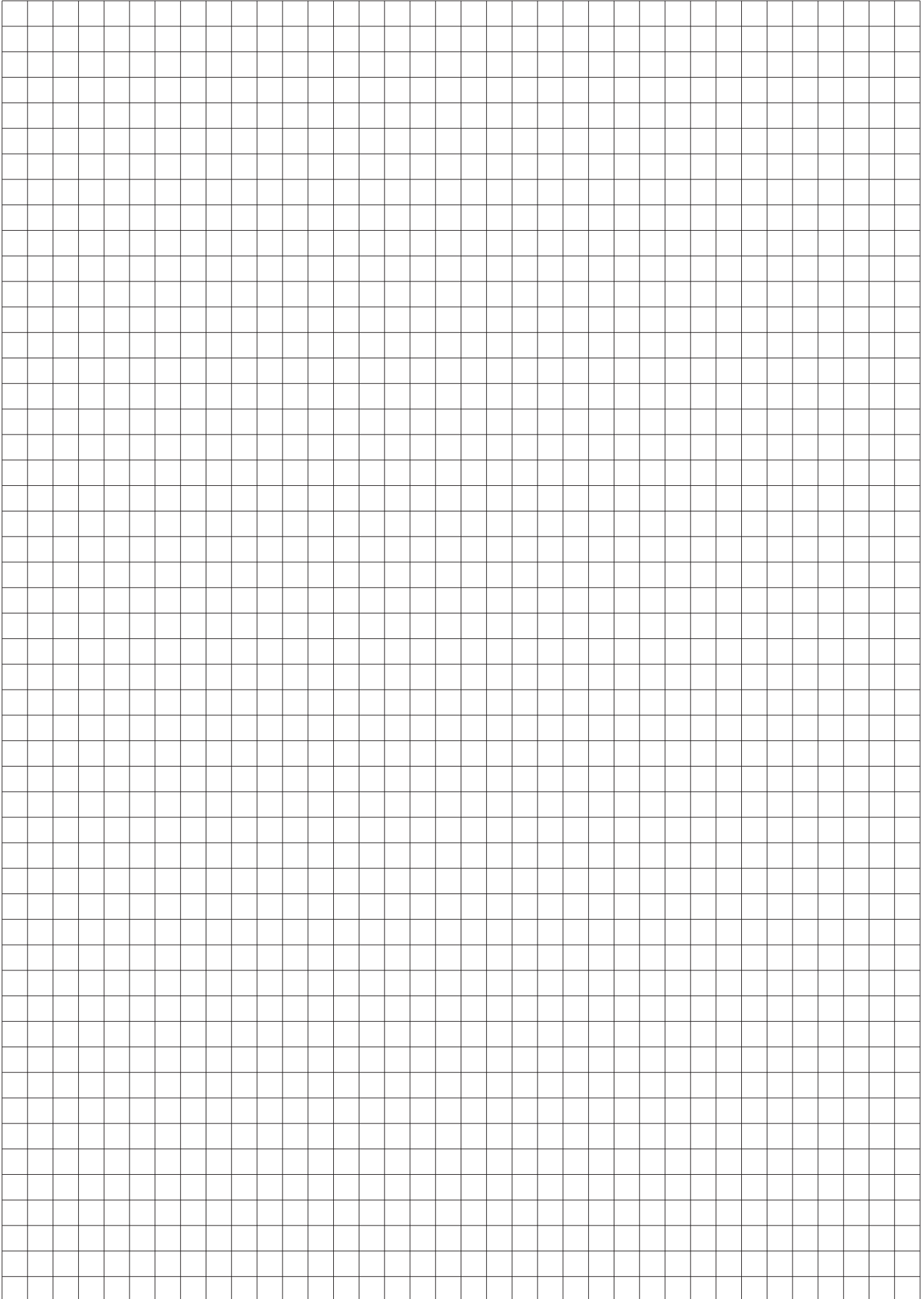

DESCRIZIONE TECNICA DEL SISTEMA

Descrizione sistema:	Sistema di profilati a taglio termico, accessori e guarnizioni per la realizzazione di serramenti a battente
Profilati estrusi lega:	EN-AW-6060 (UNI 9006 Parte 1) HB65
Tolleranze dimensionali e spessori:	UNI EN 12020-2
Caratteristiche tecniche:	<p>Giunto aperto mediante guarnizione centrale in EPDM Camera europea (accessoristica commerciale). Isolamento termico: l'interruzione del ponte termico si ottiene mediante l'inserimento di barrette in poliammide rinforzato da 35 mm, interposte tra i due elementi metallici. L'assemblaggio è eseguito mediante rullatura meccanica previa operazione di zigrinatura sugli estrusi in alluminio, al fine di evitare scorrimenti. Assemblaggio dei telai mediante squadrette a piena tubolarità a spinare e/o cianfrinare e/o da avvitare.</p>
Prestazioni termiche:	Per i principali valori U_f consultare le schede IT del catalogo.
Prestazioni del Sistema: Riferimenti Normativi EN 14351-1:2006	<p>Permeabilità all'aria: CLASSE 4 EN 1026:2000 EN 12207:1999 Tenuta all'acqua: e 1500 EN 1027:2000 EN 12208:1999 Resistenza al carico del vento: C5 EN 12211:2000 EN 12210:1999</p>
Applicazione vetro:	Con fermavetro a scatto.
Altezza sede vetro:	22 mm
Spazio per vetri/pannelli:	Possibilità di inserimento di vetri con spessori variabili da 24 a 38 mm
Inserimento vetro:	15 mm
Dimensioni del sistema:	<p>Disponibile nelle soluzioni complanare esterno / sormonto interno oppure sormonto esterno / sormonto interno. Per la prima soluzione i profili per finestre e portefinestre hanno lo spessore del telaio fisso di 73 mm e dell'anta di 83 mm con sormonto di 10 mm fra la superficie delle parti mobili e quella delle parti fisse. La seconda soluzione prevede telai fissi da 81 mm ed ante da 83 mm Sovrapposizione battuta interna: 6 mm.</p>
Impiego:	Costruzione di finestre e porte balcone a una o più ante a battente con eventuali specchiature fisse; finestre a wasistas, finestre e anta-ribalta, scorrevoli paralleli ed aperture a sporgere.
Caratteristiche estetiche:	Nella SOLUZIONE TONDA le ante, i fermavetri ed i telai si presentano con superfici molto raggiate e/o tondeggianti.

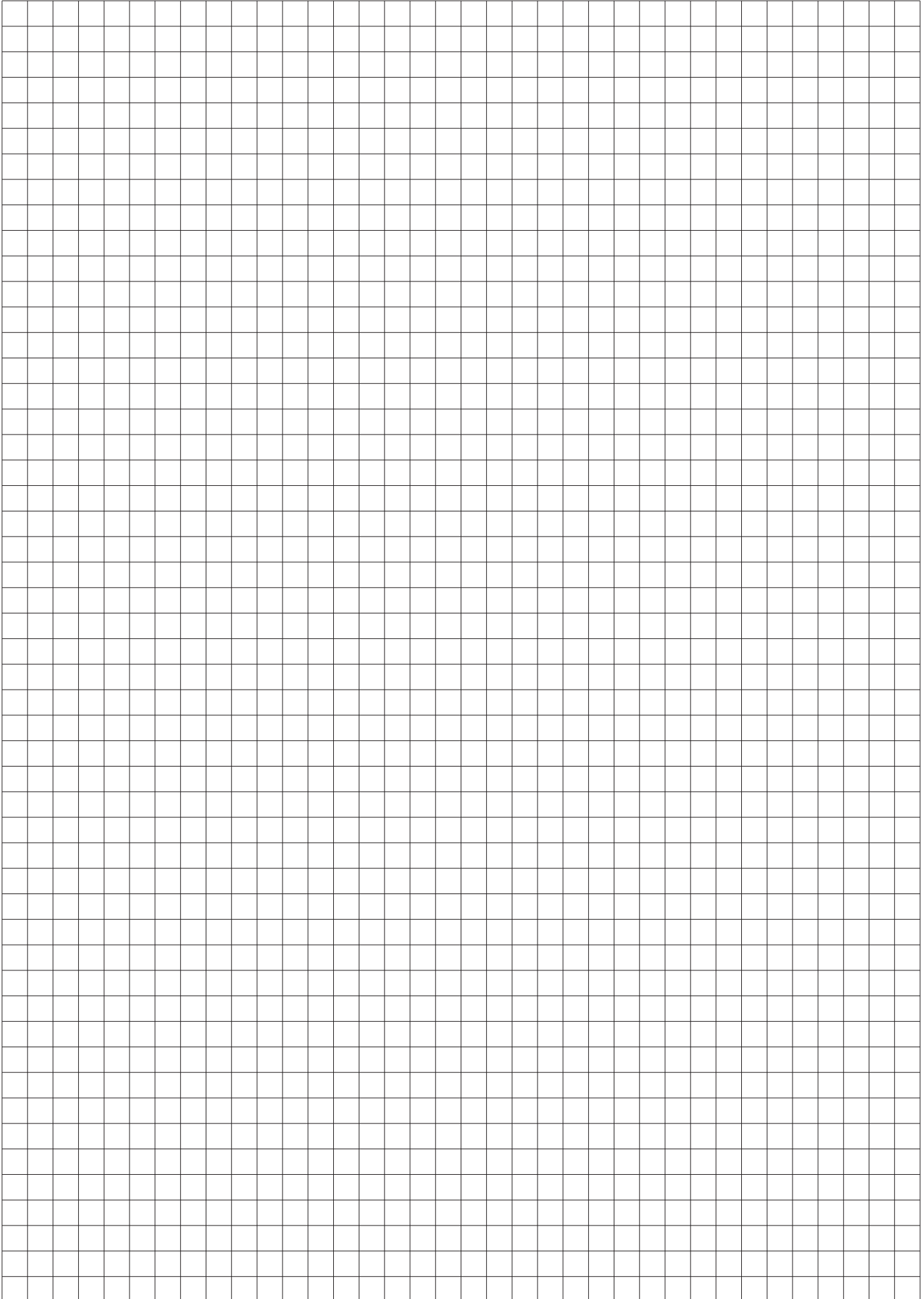

*PRESTAZIONI TERMICHE DEL SISTEMA**TRASMITTANZE TERMICHE UNITARIE DEL SISTEMA "U_f"*

Nel presente manuale sono stati pubblicati solo i principali valori della soluzione BASE del sistema **TGP TH73** per poter permettere di fare delle valutazioni IMMEDIATE circa le PRESTAZIONI TERMICHE

Tutti i calcoli completi , eseguiti presso il nostro ufficio Progettazione e Sviluppo secondo normative Uni EN Iso 10077-2 :2006 con programma di calcolo agli elementi finiti validato , sono disponibili a richiesta

TRASMITTANZA TERMICA COMPLESSIVA "U_w"

Si tratta di un valore diverso per ogni singola tipologia

E' possibile valutarlo teoricamente conoscendo diverse variabili quali spessore e caratteristiche termiche del vetrocamera, la dimensione del serramento finito ed i valori UF dei singoli nodi ,ecc.SECONDO UNI EN ISO 10077-1:2007

A titolo rappresentativo, abbiamo verificato applicando le condizioni piu' severe chieste dalla legge,se i nostri serramenti finiti rientrassero nei valori U_w massimi richiesti (quelli della zona F dal 2010) con valori di uW pari o inferiori a 2.0 W/m2K (CFR dati tratti da D.lgs 311)

I risultati confermano che gia' la soluzione BASE , senza necessita ' di ulteriori ' accorgimenti (come ad esempio l'inserimento di materiali isolanti fra le barrette fra l'altro POSSIBILE IN CASI DI RICHIESTE DI UNA ULTERIORE PERFORMANCE TERMICA) rispetta a pieno tutti i requisiti

PRESTAZIONI TERMICHE DI BASE

TRASMITTANZA TERMICA UNITARIA $U_{Frame} = 2.05 \text{ W}/(\text{m}^2 \cdot \text{K})$

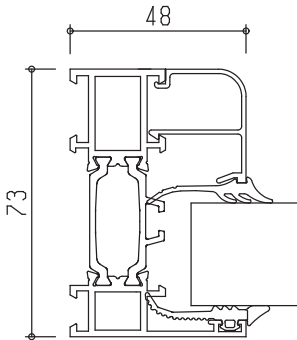

TRASMITTANZA TERMICA COMPLESSIVA

ESEMPI di CALCOLO SU:
FINESTRA 1 ANTA DIM 1230x1480

$U_{WINDOW} = 1.71 \text{ W}/\text{m}^2\text{K}$
VETRO $U_G = 1.3 \text{ W}/\text{mK}$
VALORE PSI 0.11



$U_{WINDOW} = 1.54 \text{ W}/\text{m}^2\text{K}$
VETRO $U_G = 1.1 \text{ W}/\text{mK}$
VALORE PSI 0.11

TRASMITTANZA TERMICA UNITARIA $U_{Frame} = 2.17 \text{ W}/(\text{m}^2 \cdot \text{K})$

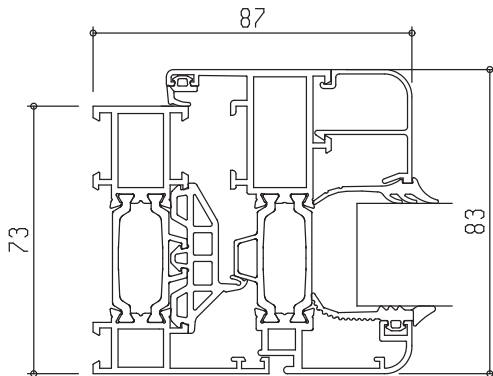

TRASMITTANZA TERMICA COMPLESSIVA

ESEMPI di CALCOLO SU:
FINESTRA 1 ANTA DIM 1230x1480

$U_{WINDOW} = 1.80 \text{ W}/\text{m}^2\text{K}$
VETRO $U_G = 1.3 \text{ W}/\text{mK}$
VALORE PSI 0.11



$U_{WINDOW} = 1.64 \text{ W}/\text{m}^2\text{K}$
VETRO $U_G = 1.1 \text{ W}/\text{mK}$
VALORE PSI 0.11

TRASMITTANZA TERMICA UNITARIA $U_{Frame} = 2.04 \text{ W}/(\text{m}^2 \cdot \text{K})$

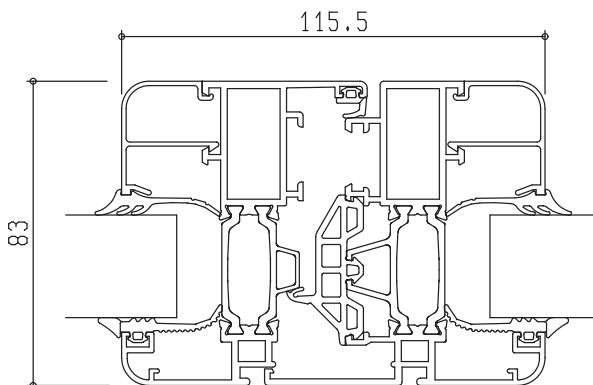

TRASMITTANZA TERMICA COMPLESSIVA

ESEMPI di CALCOLO SU:
FINESTRA 2 ANTE DIM 1230x1480

$U_{WINDOW} = 2.0 \text{ W}/\text{m}^2\text{K}$
VETRO $U_G = 1.3 \text{ W}/\text{mK}$
VALORE PSI 0.11

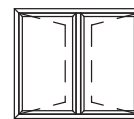

$U_{WINDOW} = 1.87 \text{ W}/\text{m}^2\text{K}$
VETRO $U_G = 1.1 \text{ W}/\text{mK}$
VALORE PSI 0.11

TRASMITTANZA TERMICA UNITARIA $U_{Frame} = 2.08 \text{ W}/(\text{m}^2 \cdot \text{K})$

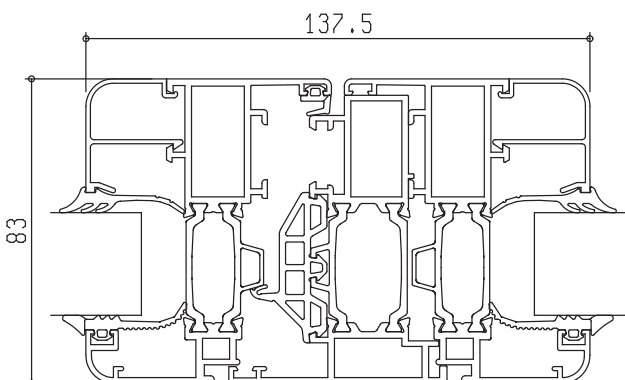

TRASMITTANZA TERMICA COMPLESSIVA

ESEMPIO di CALCOLO SU:
FINESTRA 2 ANTE DIM 1230x1480

$U_{WINDOW} = 2.01 \text{ W}/\text{m}^2\text{K}$
VETRO $U_G = 1.3 \text{ W}/\text{mK}$
VALORE PSI 0.11

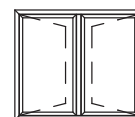

$U_{WINDOW} = 1.88 \text{ W}/\text{m}^2\text{K}$
VETRO $U_G = 1.1 \text{ W}/\text{mK}$
VALORE PSI 0.11

PRESTAZIONI TERMICHE DI BASE

TRASMITTANZA TERMICA UNITARIA $U_{Frame} = 2.20 \text{ W}/(\text{m}^2 \cdot \text{K})$

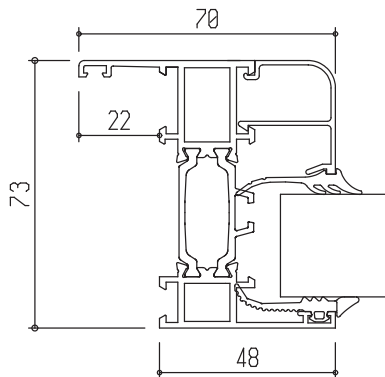

TRASMITTANZA TERMICA COMPLESSIVA

ESEMPI di CALCOLO SU:
FINESTRA 1 ANTA DIM 1230x1480

U WINDOW=1.73 $\text{W}/\text{m}^2\text{K}$
VETRO UG= 1.3 W/mK
VALORE PSI 0.11



U WINDOW=1.56 $\text{W}/\text{m}^2\text{K}$
VETRO UG= 1.1 W/mK
VALORE PSI 0.11

TRASMITTANZA TERMICA UNITARIA $U_{Frame} = 2.32 \text{ W}/(\text{m}^2 \cdot \text{K})$

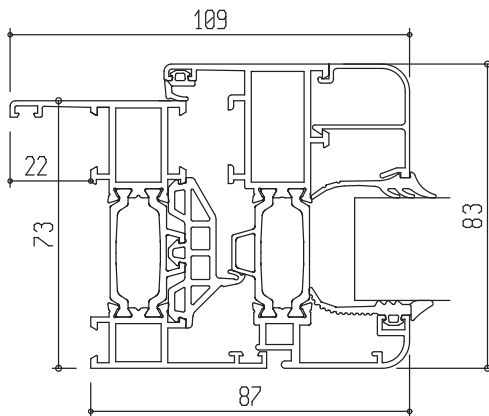

TRASMITTANZA TERMICA COMPLESSIVA

ESEMPI di CALCOLO SU:
FINESTRA 1 ANTA DIM 1230x1480

U WINDOW=1.83 $\text{W}/\text{m}^2\text{K}$
VETRO UG= 1.3 W/mK
VALORE PSI 0.11



U WINDOW=1.68 $\text{W}/\text{m}^2\text{K}$
VETRO UG= 1.1 W/mK
VALORE PSI 0.11

TRASMITTANZA TERMICA UNITARIA $U_{Frame} = 2.23 \text{ W}/(\text{m}^2 \cdot \text{K})$

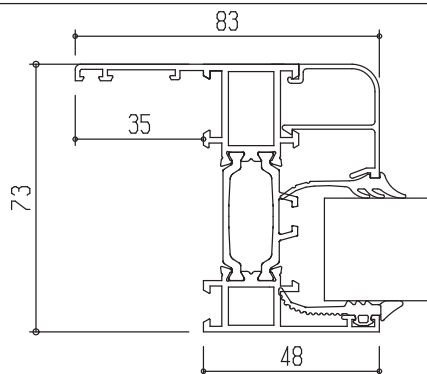

TRASMITTANZA TERMICA COMPLESSIVA

ESEMPI di CALCOLO SU:
FINESTRA 1 ANTA DIM 1230x1480

U WINDOW=1.73 $\text{W}/\text{m}^2\text{K}$
VETRO UG= 1.3 W/mK
VALORE PSI 0.11



U WINDOW=1.56 $\text{W}/\text{m}^2\text{K}$
VETRO UG= 1.1 W/mK
VALORE PSI 0.11

TRASMITTANZA TERMICA UNITARIA $U_{Frame} = 2.37 \text{ W}/(\text{m}^2 \cdot \text{K})$

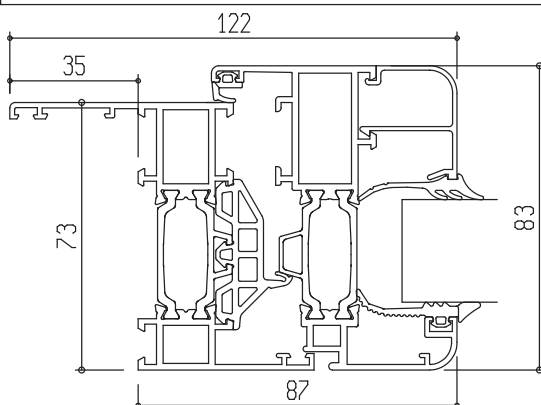

TRASMITTANZA TERMICA COMPLESSIVA

ESEMPIO di CALCOLO SU:
FINESTRA 1 ANTA DIM 1230x1480

U WINDOW=1.84 $\text{W}/\text{m}^2\text{K}$
VETRO UG= 1.3 W/mK
VALORE PSI 0.11



U WINDOW=1.69 $\text{W}/\text{m}^2\text{K}$
VETRO UG= 1.1 W/mK
VALORE PSI 0.11

PRESTAZIONI TERMICHE DI BASE

VALIDE PER TUTTE
LE LINEE ESTETICHE

TRASMITTANZA TERMICA UNITARIA $U_{Frame} = 2.05 \text{ W}/(\text{m}^2 \cdot \text{K})$

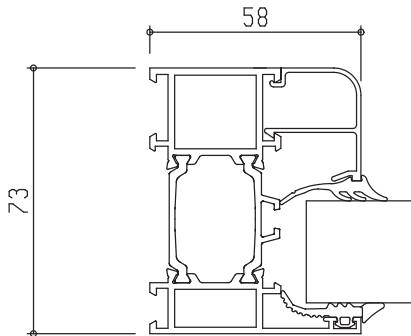

TRASMITTANZA TERMICA COMPLESSIVA

ESEMPI di CALCOLO SU:
FINESTRA 1 ANTA DIM 1230x1480

$U_{WINDOW} = 1.71 \text{ W}/\text{m}^2\text{K}$
VETRO UG= 1.3 W/mK
VALORE PSI 0.11



$U_{WINDOW} = 1.56 \text{ W}/\text{m}^2\text{K}$
VETRO UG= 1.1 W/mK
VALORE PSI 0.11

TRASMITTANZA TERMICA UNITARIA $U_{Frame} = 2.13 \text{ W}/(\text{m}^2 \cdot \text{K})$

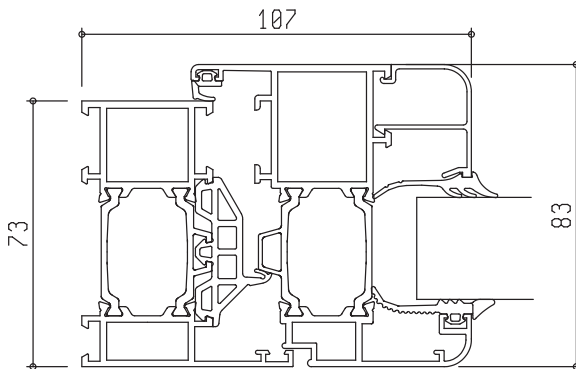

TRASMITTANZA TERMICA COMPLESSIVA

ESEMPI di CALCOLO SU:
FINESTRA 1 ANTA DIM 1230x1480

$U_{WINDOW} = 1.80 \text{ W}/\text{m}^2\text{K}$
VETRO UG= 1.3 W/mK
VALORE PSI 0.11



$U_{WINDOW} = 1.68 \text{ W}/\text{m}^2\text{K}$
VETRO UG= 1.1 W/mK
VALORE PSI 0.11

TRASMITTANZA TERMICA UNITARIA $U_{Frame} = 2.00 \text{ W}/(\text{m}^2 \cdot \text{K})$

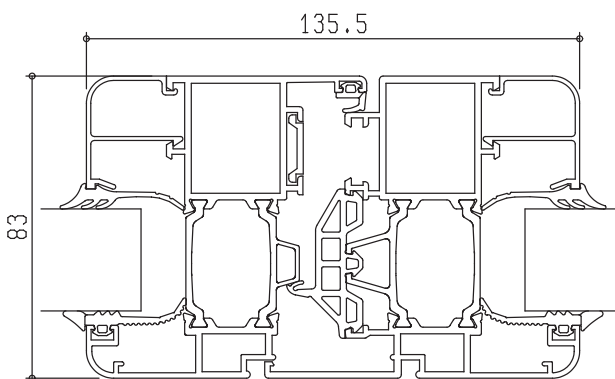

TRASMITTANZA TERMICA COMPLESSIVA

ESEMPI di CALCOLO SU:
FINESTRA 2 ANTE DIM 1230x1480

$U_{WINDOW} = 2.0 \text{ W}/\text{m}^2\text{K}$
VETRO UG= 1.3 W/mK
VALORE PSI 0.11

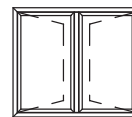

$U_{WINDOW} = 1.92 \text{ W}/\text{m}^2\text{K}$
VETRO UG= 1.1 W/mK
VALORE PSI 0.11

TRASMITTANZA TERMICA UNITARIA $U_{Frame} = 2.05 \text{ W}/(\text{m}^2 \cdot \text{K})$

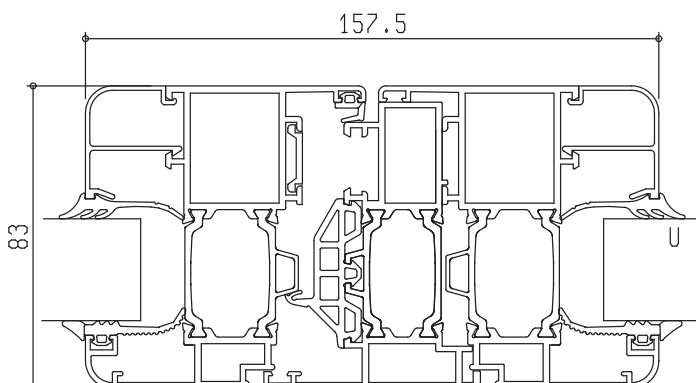

TRASMITTANZA TERMICA COMPLESSIVA

ESEMPIO di CALCOLO SU:
FINESTRA 2 ANTE DIM 1230x1480

$U_{WINDOW} = 2.01 \text{ W}/\text{m}^2\text{K}$
VETRO UG= 1.3 W/mK
VALORE PSI 0.11

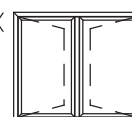

$U_{WINDOW} = 1.88 \text{ W}/\text{m}^2\text{K}$
VETRO UG= 1.1 W/mK
VALORE PSI 0.11

PRESTAZIONI TERMICHE DI BASE

VALIDE PER TUTTE
LE LINEE ESTETICHE

TRASMITTANZA TERMICA UNITARIA $U_{Frame} = 2.18 \text{ W}/(\text{m}^2 \cdot \text{K})$

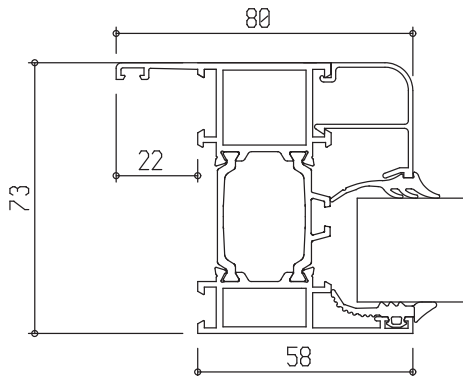

TRASMITTANZA TERMICA COMPLESSIVA

ESEMPI di CALCOLO SU:

FINESTRA 1 ANTA DIM. 1230x1480 mm

$U_{WINDOW} = 1.74 \text{ W}/\text{m}^2\text{K}$
VETRO UG= 1.3 W/mK
VALORE PSI 0.11



$U_{WINDOW} = 1.58 \text{ W}/\text{m}^2\text{K}$
VETRO UG= 1.1 W/mK
VALORE PSI 0.11

TRASMITTANZA TERMICA UNITARIA $U_{Frame} = 2.25 \text{ W}/(\text{m}^2 \cdot \text{K})$

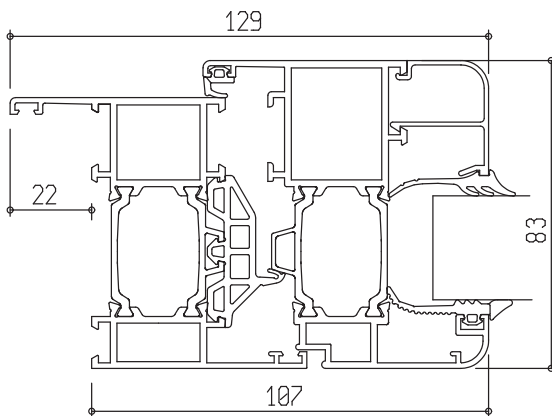

TRASMITTANZA TERMICA COMPLESSIVA

ESEMPI di CALCOLO SU:

FINESTRA 1 ANTA DIM. 1230x1480 mm

$U_{WINDOW} = 1.85 \text{ W}/\text{m}^2\text{K}$
VETRO UG= 1.3 W/mK
VALORE PSI 0.11



$U_{WINDOW} = 1.71 \text{ W}/\text{m}^2\text{K}$
VETRO UG= 1.1 W/mK
VALORE PSI 0.11

TRASMITTANZA TERMICA UNITARIA $U_{Frame} = 2.23 \text{ W}/(\text{m}^2 \cdot \text{K})$

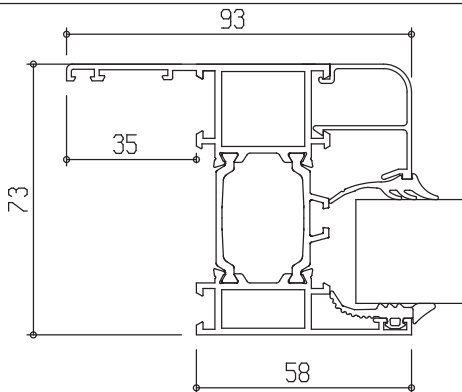

TRASMITTANZA TERMICA COMPLESSIVA

ESEMPI di CALCOLO SU:

FINESTRA 1 ANTA DIM. 1230x1480 mm

$U_{WINDOW} = 1.75 \text{ W}/\text{m}^2\text{K}$
VETRO UG= 1.3 W/mK
VALORE PSI 0.11



$U_{WINDOW} = 1.59 \text{ W}/\text{m}^2\text{K}$
VETRO UG= 1.1 W/mK
VALORE PSI 0.11

TRASMITTANZA TERMICA UNITARIA $U_{Frame} = 2.29 \text{ W}/(\text{m}^2 \cdot \text{K})$

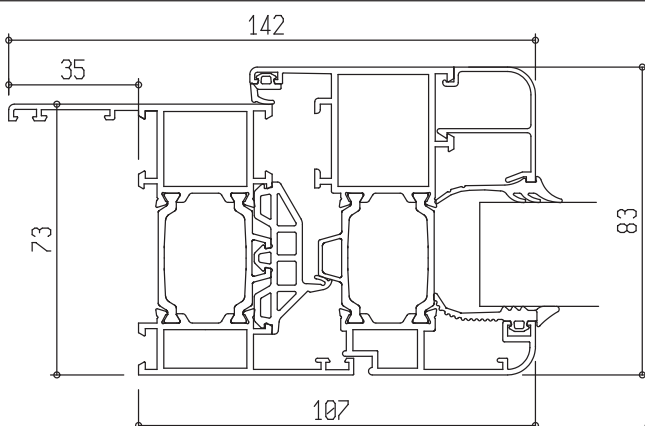

TRASMITTANZA TERMICA COMPLESSIVA

ESEMPI di CALCOLO SU:

FINESTRA 1 ANTA DIM. 1230x1480 mm

$U_{WINDOW} = 1.87 \text{ W}/\text{m}^2\text{K}$
VETRO UG= 1.3 W/mK
VALORE PSI 0.11

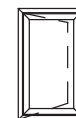

$U_{WINDOW} = 1.72 \text{ W}/\text{m}^2\text{K}$
VETRO UG= 1.1 W/mK
VALORE PSI 0.11

PRESTAZIONI TERMICHE DI BASE

VALIDE PER TUTTE
LE LINEE ESTETICHE

TRASMITTANZA TERMICA UNITARIA $U_{Frame} = 2.02 \text{ W}/(\text{m}^2 \cdot \text{K})$

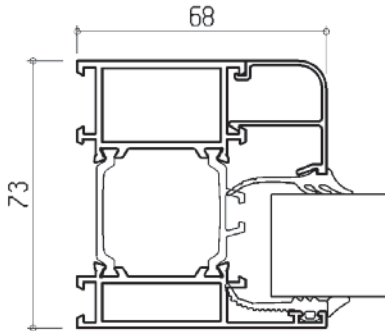

TRASMITTANZA TERMICA COMPLESSIVA

ESEMPIO di CALCOLO SU:
FINESTRA 1 ANTA DIM. 1230x1480 mm



VETRO UG= 1.1 W/mK
VALORE PSI 0.11

VALORE UW 1.57 W/(m²K)

TRASMITTANZA TERMICA UNITARIA $U_{Frame} = 2.05 \text{ W}/(\text{m}^2 \cdot \text{K})$

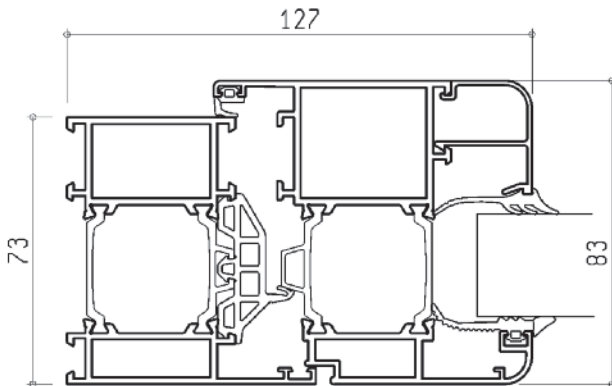

TRASMITTANZA TERMICA COMPLESSIVA

ESEMPIO di CALCOLO SU:
FINESTRA 1 ANTA DIM. 1230x1480 mm



VETRO UG= 1.1 W/mK
VALORE PSI 0.11

VALORE UW 1.69 W/(m²K)

TRASMITTANZA TERMICA UNITARIA $U_{Frame} = 1.97 \text{ W}/(\text{m}^2 \cdot \text{K})$

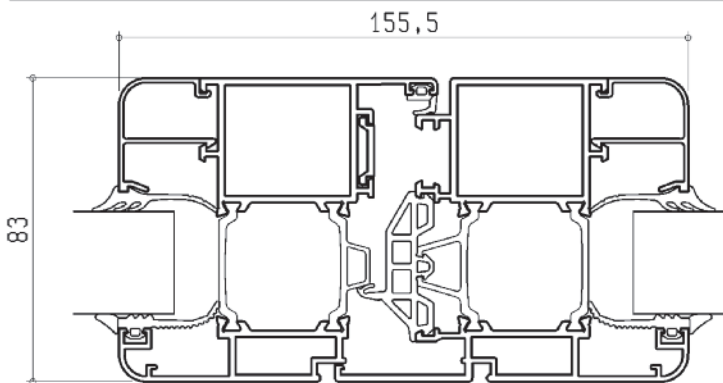

TRASMITTANZA TERMICA COMPLESSIVA

ESEMPIO di CALCOLO SU:
FINESTRA 2 ANTE DIM. 1230x1480 mm



VETRO UG= 1.1 W/mK
VALORE PSI 0.11

VALORE UW 1.91 W/(m²K)

TRASMITTANZA TERMICA UNITARIA $U_{Frame} = 1.99 \text{ W}/(\text{m}^2 \cdot \text{K})$

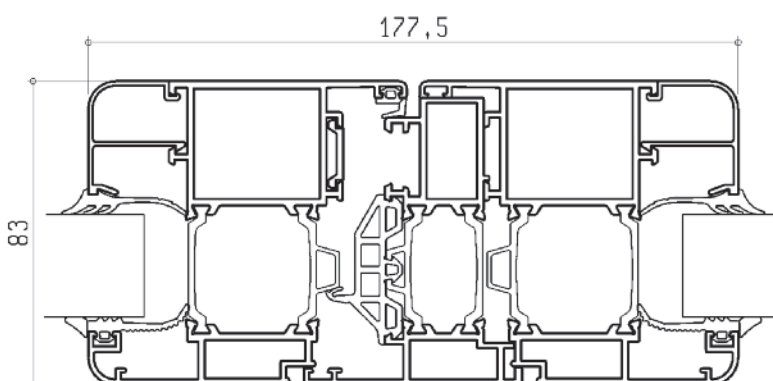

TRASMITTANZA TERMICA COMPLESSIVA

ESEMPIO di CALCOLO SU:
FINESTRA 2 ANTE DIM. 1230x1480 mm



VETRO UG= 1.1 W/mK
VALORE PSI 0.11

VALORE UW 1.91 W/(m²K)

PRESTAZIONI TERMICHE DI BASE per sporgere

TRASMITTANZA TERMICA
UNITARIA

Sezione verticale
 $U_{Frame} = 2.74 \text{ W}/(\text{m}^2 \cdot \text{K})$

Sezione orizzontale
 $U_{Frame} = 2.74 \text{ W}/(\text{m}^2 \cdot \text{K})$

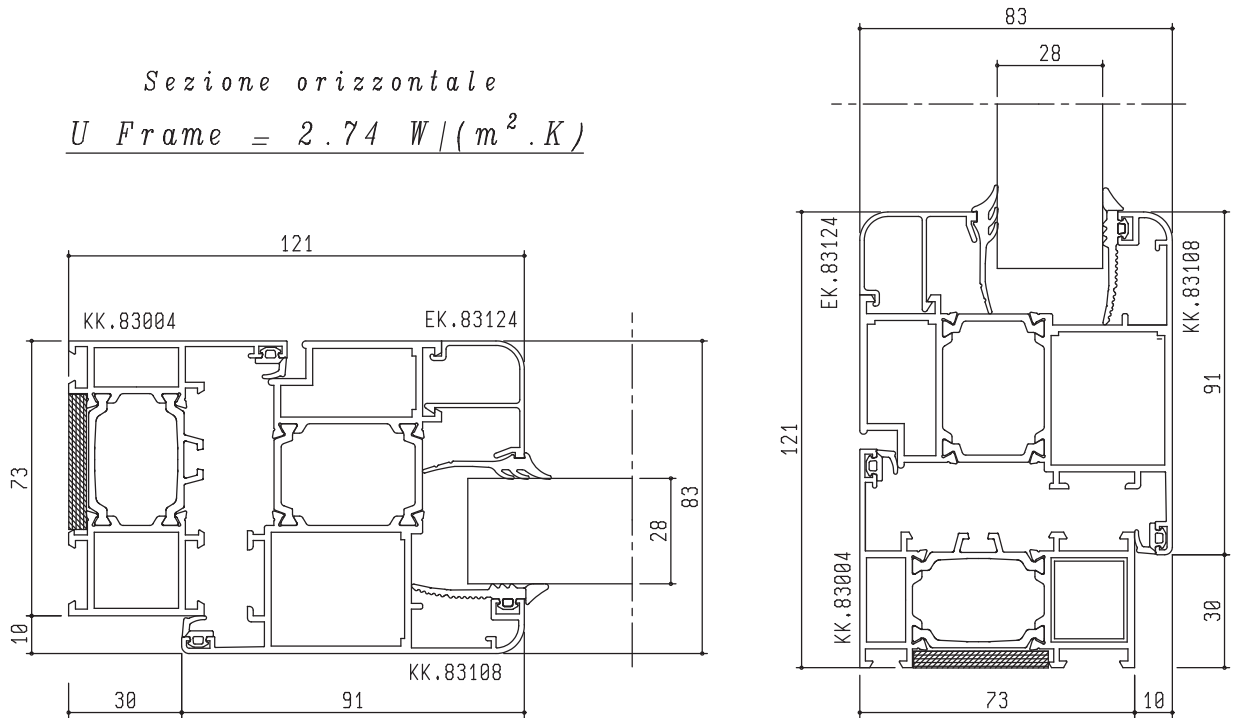

TRASMITTANZA TERMICA COMPLESSIVA

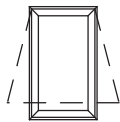

Prospetto visto
dall'esterno

ESEMPIO di CALCOLO SU : FINESTRA 1 ANTA DIM 1230x1480
VETRO $U_G = 1.3 \text{ W}/\text{mK}$
VALORE PSI 0.11
VALORE $U_W 2.04 \text{ W}/(\text{m}^2 \cdot \text{K})$

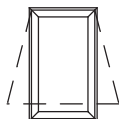

Prospetto visto
dall'esterno

ESEMPIO di CALCOLO SU : FINESTRA 1 ANTA DIM 1230x1480
VETRO $U_G = 1.1 \text{ W}/\text{mK}$
VALORE PSI 0.11
VALORE $U_W 1.91 \text{ W}/(\text{m}^2 \cdot \text{K})$

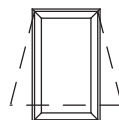

Prospetto visto
dall'esterno

ESEMPIO di CALCOLO SU : FINESTRA 1 ANTA DIM 1230x1480
VETRO $U_G = 1.0 \text{ W}/\text{mK}$
VALORE PSI 0.11
VALORE $U_W 1.84 \text{ W}/(\text{m}^2 \cdot \text{K})$

VALIDE PER TUTTE
LE LINEE ESTETICHE

TRASMITTANZA TERMICA UNITARIA
"Uf" (U Frame)

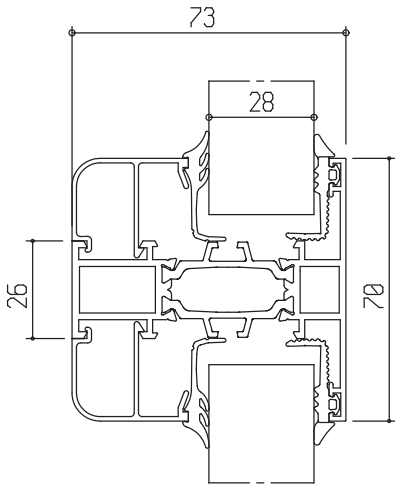

Valore Uf nodo
Fascia
26/70 mm
*TRASMITTANZA
TERMICA
UNITARIA*
U Frame
1.90 W/(m²K)

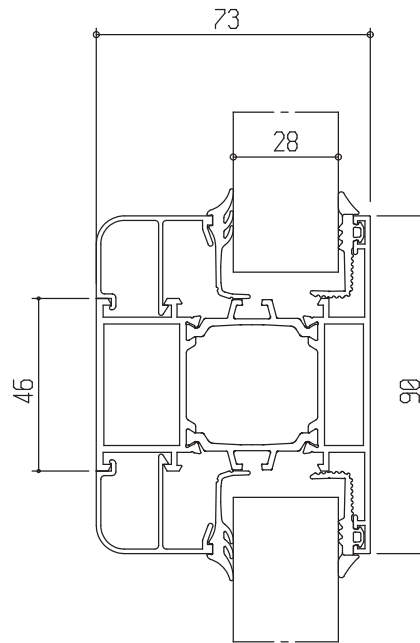

Valore Uf nodo
Fascia
46/90 mm
*TRASMITTANZA
TERMICA
UNITARIA*
U Frame
1.89 W/(m²K)

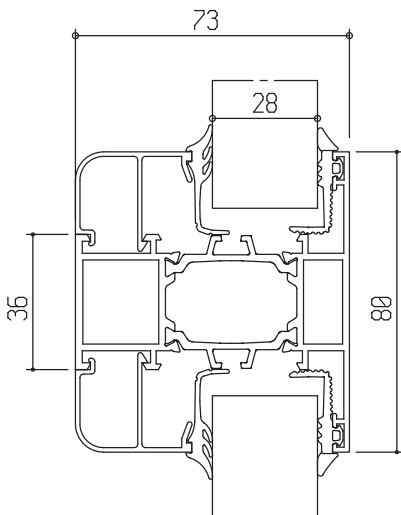

Valore Uf nodo
Fascia
36/90 mm
*TRASMITTANZA
TERMICA
UNITARIA*
U Frame
1.91 W/(m²K)

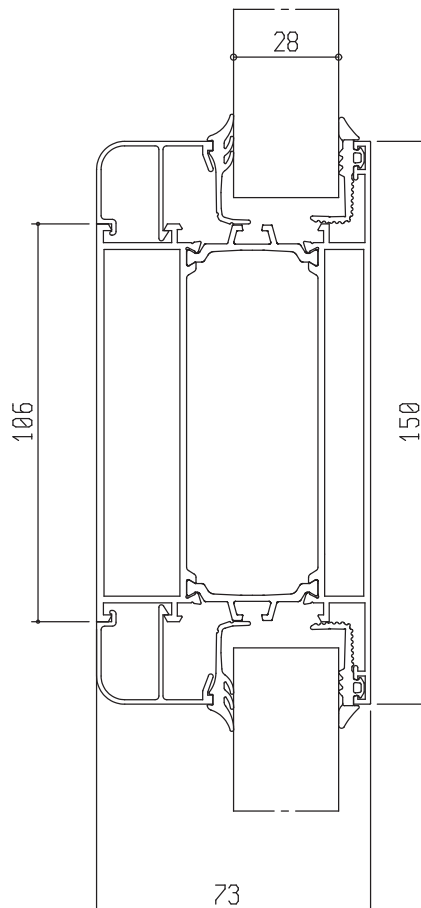

Valore Uf nodo
Fascia
106/150 mm
*TRASMITTANZA
TERMICA
UNITARIA*
U Frame
1.84 W/(m²K)

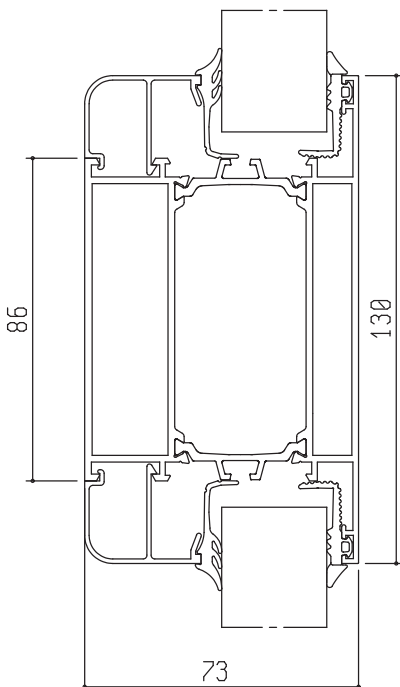

Valore Uf nodo
Fascia
86/130 mm
*TRASMITTANZA
TERMICA
UNITARIA*
U Frame
1.86 W/(m²K)

VALIDE PER TUTTE
LE LINEE ESTETICHE

TRASMITTANZA TERMICA UNITARIA
"U_f" (U Frame)

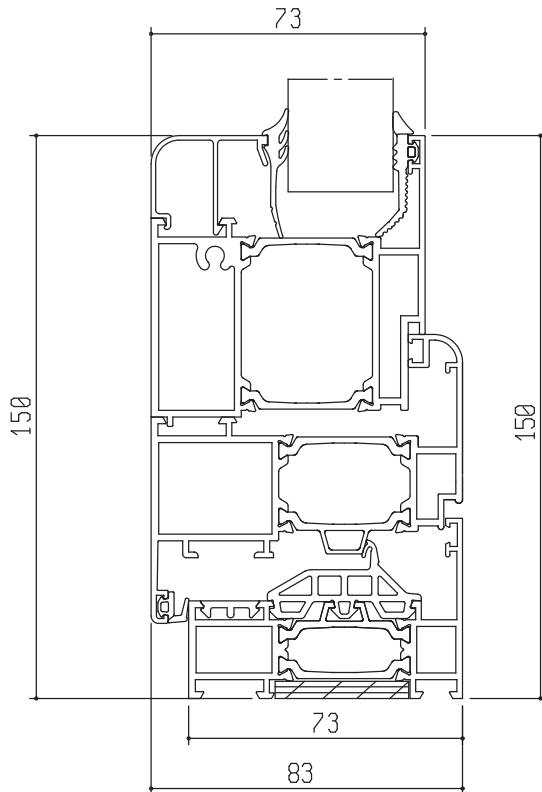

Valore U_f nodo
soglia con zoccolo riportato
TRASMITTANZA TERMICA UNITARIA

$$U_{Frame} = 2.21 \text{ W}/(\text{m}^2 \cdot \text{K})$$

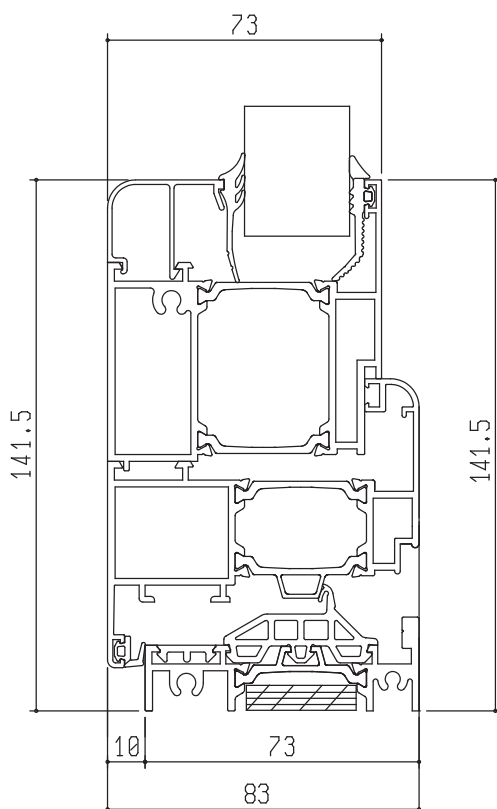

Valore U_f nodo
soglia ribassata e zoccolo riportato
TRASMITTANZA TERMICA UNITARIA

$$U_{Frame} = 2.34 \text{ W}/(\text{m}^2 \cdot \text{K})$$

TRASMITTANZA TERMICA UNITARIA

*VALIDE PER TUTTE
LE LINEE ESTETICHE*

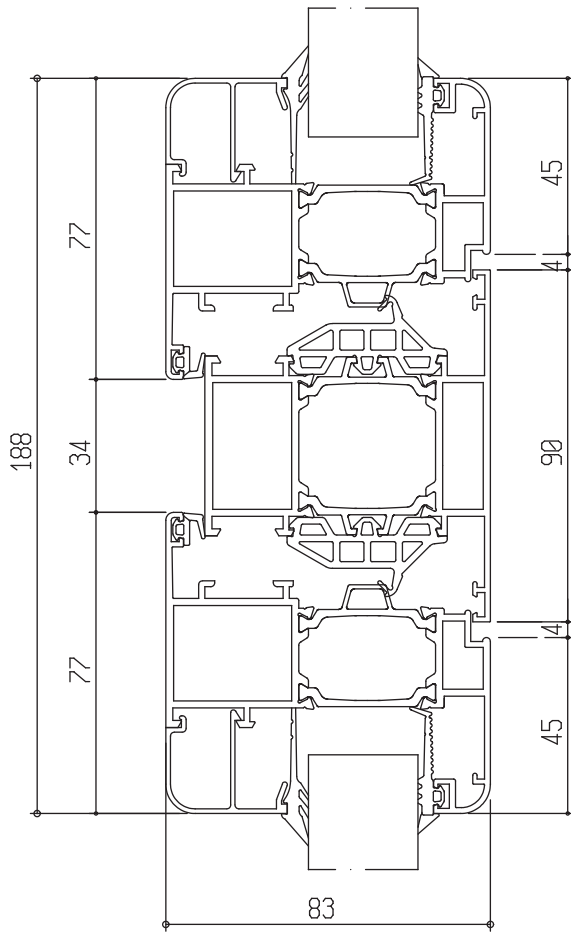

Valore Uf nodo
TRASMITTANZA TERMICA UNITARIA
 $U_{Frame} = 2.07 \text{ W / (m}^2 \cdot \text{K)}$

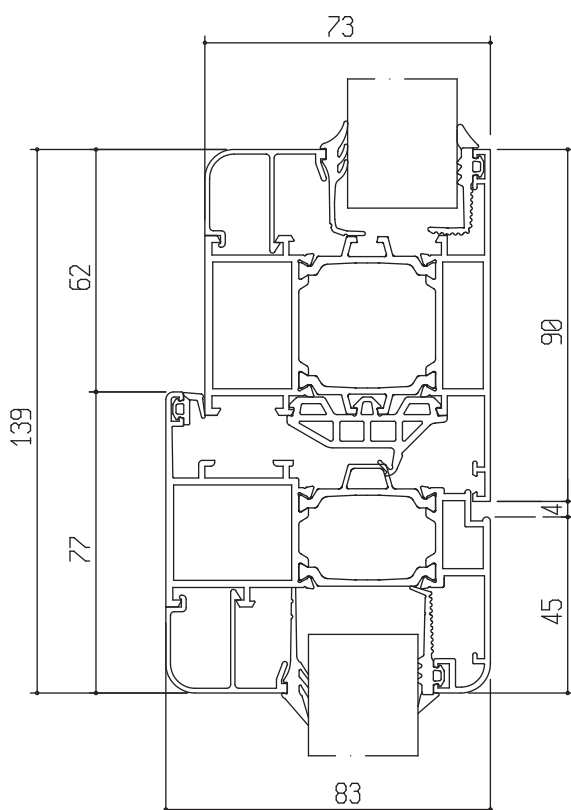

Valore Uf nodo
TRASMITTANZA TERMICA UNITARIA
 $U_{Frame} = 2.03 \text{ W / (m}^2 \cdot \text{K)}$

PRESTAZIONI TERMICHE IN RISPETTO AL DM 26 GENNAIO 2010
 VALIDE PER TUTTE LE LINEE ESTETICHE (ZONE E-F)

TRASMITTANZA TERMICA UNITARIA $U_{Frame} = 1.69 W/(m^2.K)$

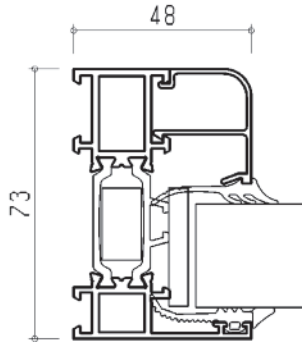

TRASMITTANZA TERMICA COMPLESSIVA

ESEMPI di CALCOLO SU:
 FINESTRA 1 ANTA DIM. 1230x1480 mm

U WINDOW= 1.49 W/m^2K
 VETRO UG= 1.1 W/mK
 VALORE PSI 0.11



U WINDOW= 1.66 W/m^2K
 VETRO UG= 1.3 W/mK
 VALORE PSI 0.11

TRASMITTANZA TERMICA UNITARIA $U_{Frame} = 1.91 W/(m^2.K)$

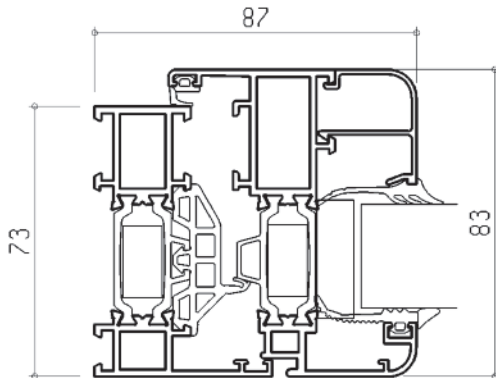

TRASMITTANZA TERMICA COMPLESSIVA

ESEMPI di CALCOLO SU:
 FINESTRA 1 ANTA DIM. 1230x1480 mm

U WINDOW= 1.58 W/m^2K
 VETRO UG= 1.1 W/mK
 VALORE PSI 0.11



U WINDOW= 1.73 W/m^2K
 VETRO UG= 1.3 W/mK
 VALORE PSI 0.11

TRASMITTANZA TERMICA UNITARIA $U_{Frame} = 1.70 W/(m^2.K)$

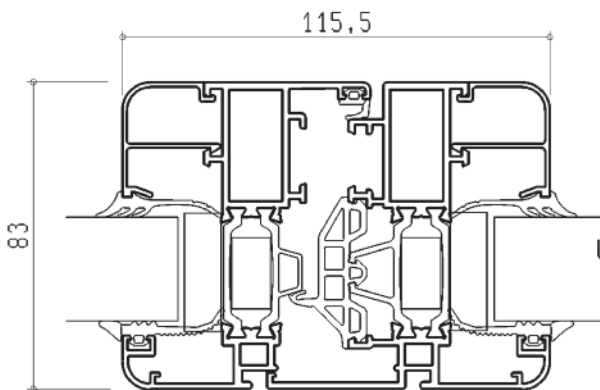

TRASMITTANZA TERMICA COMPLESSIVA

ESEMPI di CALCOLO SU:
 FINESTRA 2 ANTE DIM. 1230x1480 mm

U WINDOW= 1.59 W/m^2K
 VETRO UG= 1.0 W/mK
 VALORE PSI 0.08
 (WORM EDGE)



U WINDOW= 1.78 W/m^2K
 VETRO UG= 1.1 W/mK
 VALORE PSI 0.11

TRASMITTANZA TERMICA UNITARIA $U_{Frame} = 1.73 W/(m^2.K)$

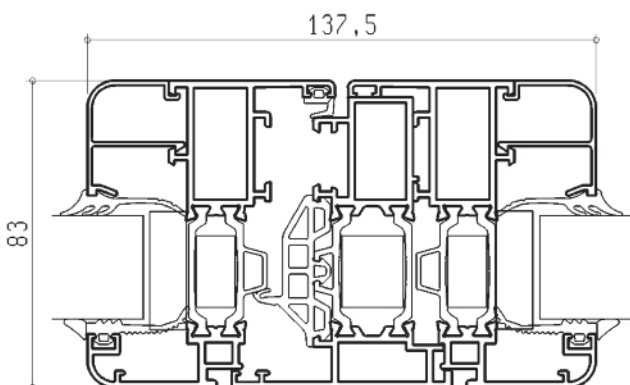

TRASMITTANZA TERMICA COMPLESSIVA

ESEMPIO di CALCOLO SU:
 FINESTRA 2 ANTE DIM. 1230x1480 mm

U WINDOW= 1.60 W/m^2K
 VETRO UG= 1.0 W/mK
 VALORE PSI 0.08
 (WORM EDGE)

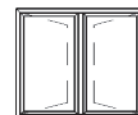

U WINDOW= 1.79 W/m^2K
 VETRO UG= 1.1 W/mK
 VALORE PSI 0.11

PRESTAZIONI TERMICHE IN RISPETTO AL DM 26 GENNAIO 2010
 VALIDE PER TUTTE LE LINEE ESTETICHE (ZONE E-F)

TRASMITTANZA TERMICA UNITARIA $U_{Frame} = 1.78 W/(m^2.K)$

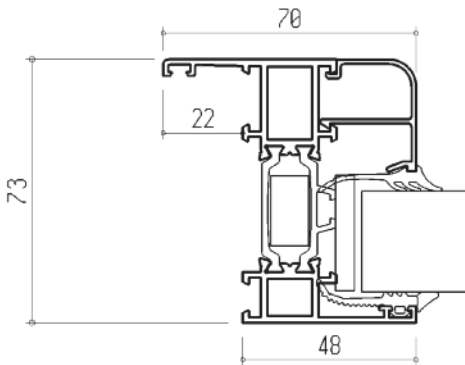

TRASMITTANZA TERMICA COMPLESSIVA

ESEMPI di CALCOLO SU:
 FINESTRA 1 ANTA DIM. 1230x1480 mm

U WINDOW= 1.50 W/m^2K
 VETRO UG= 1.1 W/mK
 VALORE PSI 0.11



U WINDOW= 1.67 W/m^2K
 VETRO UG= 1.3 W/mK
 VALORE PSI 0.11

TRASMITTANZA TERMICA UNITARIA $U_{Frame} = 2.03 W/(m^2.K)$

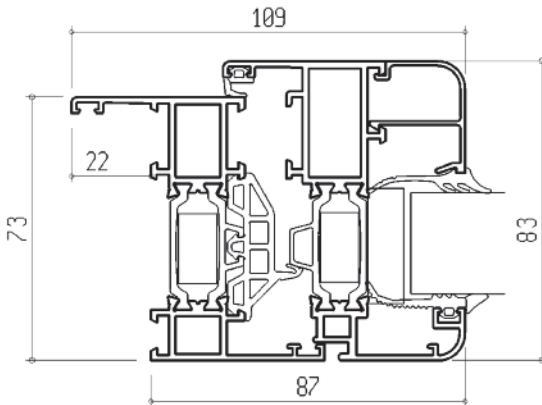

TRASMITTANZA TERMICA COMPLESSIVA

ESEMPI di CALCOLO SU:
 FINESTRA 1 ANTA DIM. 1230x1480 mm

U WINDOW= 1.54 W/m^2K
 VETRO UG= 1.0 W/mK
 VALORE PSI 0.11



U WINDOW= 1.76 W/m^2K
 VETRO UG= 1.3 W/mK
 VALORE PSI 0.11

TRASMITTANZA TERMICA UNITARIA $U_{Frame} = 1.81 W/(m^2.K)$

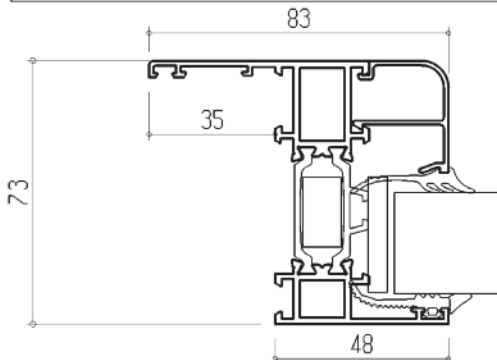

TRASMITTANZA TERMICA COMPLESSIVA

ESEMPI di CALCOLO SU:
 FINESTRA 1 ANTA DIM. 1230x1480 mm

U WINDOW= 1.50 W/m^2K
 VETRO UG= 1.1 W/mK
 VALORE PSI 0.11



U WINDOW= 1.67 W/m^2K
 VETRO UG= 1.3 W/mK
 VALORE PSI 0.11

TRASMITTANZA TERMICA UNITARIA $U_{Frame} = 2.07 W/(m^2.K)$

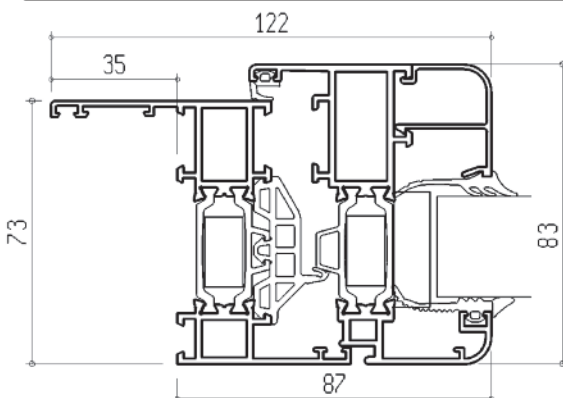

TRASMITTANZA TERMICA COMPLESSIVA

ESEMPIO di CALCOLO SU:
 FINESTRA 1 ANTA DIM. 1230x1480 mm

U WINDOW= 1.54 W/m^2K
 VETRO UG= 1.0 W/mK
 VALORE PSI 0.11



U WINDOW= 1.77 W/m^2K
 VETRO UG= 1.3 W/mK
 VALORE PSI 0.11

PRESTAZIONI TERMICHE IN RISPETTO AL DM 26 GENNAIO 2010
 VALIDE PER TUTTE LE LINEE ESTETICHE (ZONE E - F)

TRASMITTANZA TERMICA UNITARIA $U_{Frame} = 1.59 W/(m^2 \cdot K)$

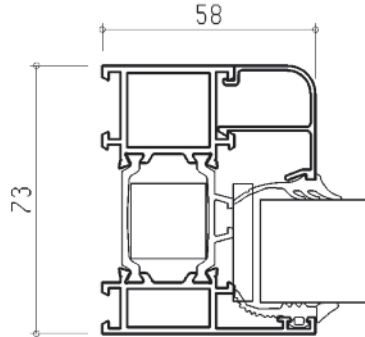

TRASMITTANZA TERMICA COMPLESSIVA

ESEMPI di CALCOLO SU:

FINESTRA 1 ANTA DIM. 1230x1480 mm

U WINDOW= 1.48 W/m²K
 VETRO UG= 1.1 W/mK
 VALORE PSI 0.11



U WINDOW= 1.65 W/m²K
 VETRO UG= 1.3 W/mK
 VALORE PSI 0.11

TRASMITTANZA TERMICA UNITARIA $U_{Frame} = 1.76 W/(m^2 \cdot K)$

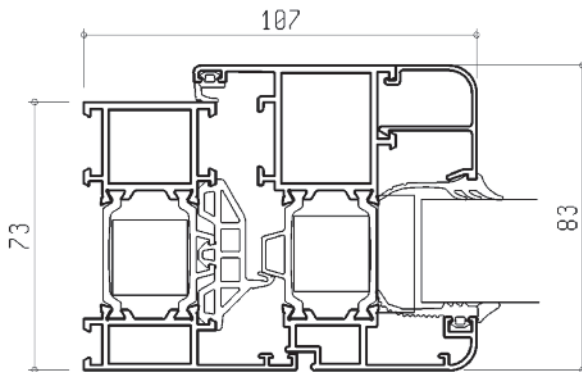

TRASMITTANZA TERMICA COMPLESSIVA

ESEMPI di CALCOLO SU:

FINESTRA 1 ANTA DIM. 1230x1480 mm

U WINDOW= 1.57 W/m²K
 VETRO UG= 1.1 W/mK
 VALORE PSI 0.11

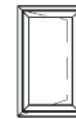

U WINDOW= 1.71 W/m²K
 VETRO UG= 1.3 W/mK
 VALORE PSI 0.11

TRASMITTANZA TERMICA UNITARIA $U_{Frame} = 1.57 W/(m^2 \cdot K)$

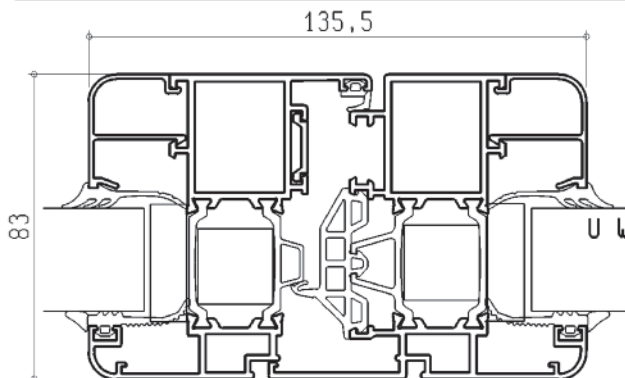

TRASMITTANZA TERMICA COMPLESSIVA

ESEMPI di CALCOLO SU:

FINESTRA 2 ANTE DIM. 1230x1480 mm

U WINDOW= 1.58 W/m²K
 VETRO UG= 1.0 W/mK
 VALORE PSI 0.08
 (WARM EDGE)



U WINDOW= 1.75 W/m²K
 VETRO UG= 1.1 W/mK
 VALORE PSI 0.11

TRASMITTANZA TERMICA UNITARIA $U_{Frame} = 1.61 W/(m^2 \cdot K)$

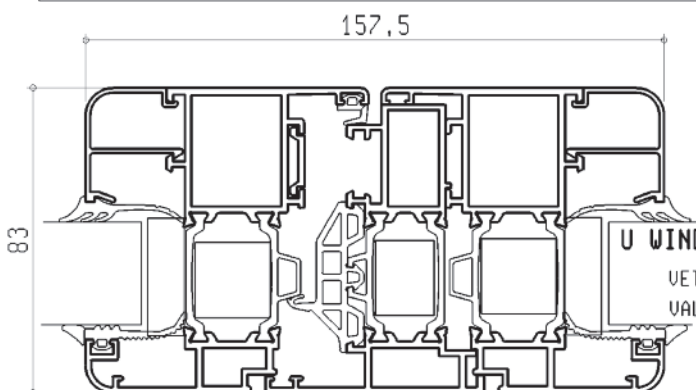

TRASMITTANZA TERMICA COMPLESSIVA

ESEMPIO di CALCOLO SU:

FINESTRA 2 ANTE DIM. 1230x1480 mm

U WINDOW= 1.59 W/m²K
 VETRO UG= 1.0 W/mK
 VALORE PSI 0.08
 (WARM EDGE)

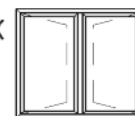

U WINDOW= 1.76 W/m²K
 VETRO UG= 1.1 W/mK
 VALORE PSI 0.11

PRESTAZIONI TERMICHE IN RISPETTO AL DM 26 GENNAIO 2010
VALIDE PER TUTTE LE LINEE ESTETICHE (ZONE E-F)

TRASMITTANZA TERMICA UNITARIA $U_{Frame} = 1.67 W/(m^2.K)$

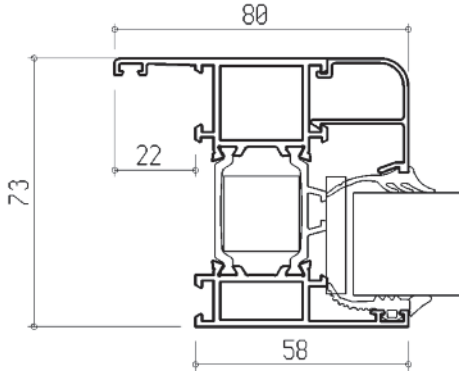

TRASMITTANZA TERMICA COMPLESSIVA

ESEMPI di CALCOLO SU:
 FINESTRA 1 ANTA DIM. 1230x1480 mm

U WINDOW= 1.49 W/m²K

VETRO UG= 1.1 W/mK
 VALORE PSI 0.11



U WINDOW= 1.67 W/m²K

VETRO UG= 1.3 W/mK
 VALORE PSI 0.11

TRASMITTANZA TERMICA UNITARIA $U_{Frame} = 1.84 W/(m^2.K)$

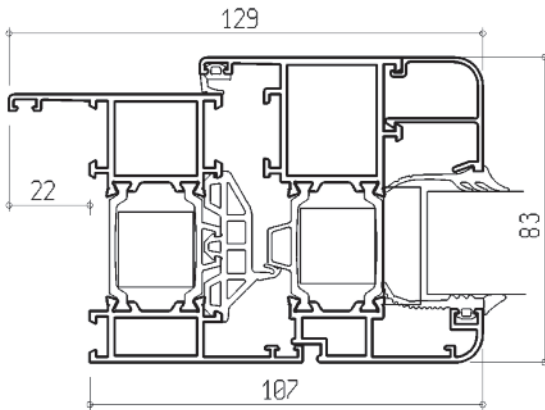

TRASMITTANZA TERMICA COMPLESSIVA

ESEMPI di CALCOLO SU:
 FINESTRA 1 ANTA DIM. 1230x1480 mm

U WINDOW= 1.59 W/m²K

VETRO UG= 1.1 W/mK
 VALORE PSI 0.11



U WINDOW= 1.73 W/m²K

VETRO UG= 1.3 W/mK
 VALORE PSI 0.11

TRASMITTANZA TERMICA UNITARIA $U_{Frame} = 1.70 W/(m^2.K)$

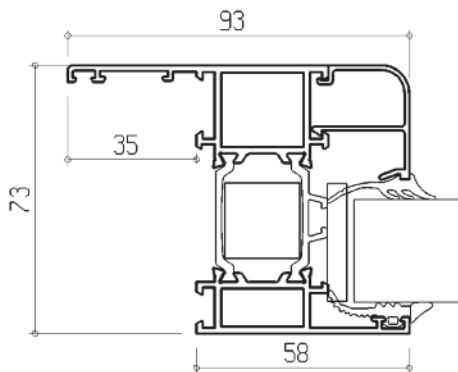

TRASMITTANZA TERMICA COMPLESSIVA

ESEMPI di CALCOLO SU:
 FINESTRA 1 ANTA DIM. 1230x1480 mm

U WINDOW= 1.50 W/m²K

VETRO UG= 1.1 W/mK
 VALORE PSI 0.11



U WINDOW= 1.68 W/m²K

VETRO UG= 1.3 W/mK
 VALORE PSI 0.11

TRASMITTANZA TERMICA UNITARIA $U_{Frame} = 1.88 W/(m^2.K)$

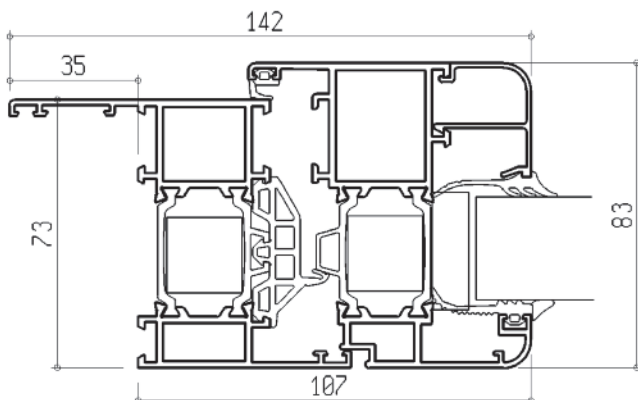

TRASMITTANZA TERMICA COMPLESSIVA

ESEMPI di CALCOLO SU:
 FINESTRA 1 ANTA DIM. 1230x1480 mm

U WINDOW= 1.53 W/m²K

VETRO UG= 1.1 W/mK
 VALORE PSI 0.11



U WINDOW= 1.75 W/m²K

VETRO UG= 1.3 W/mK
 VALORE PSI 0.11

PRESTAZIONI TERMICHE IN RISPETTO AL DM 26 GENNAIO 2010
VALIDE PER TUTTE LE LINEE ESTETICHE (ZONE E-F)

TRASMITTANZA TERMICA UNITARIA $U_{Frame} = 1.49 W/(m^2.K)$

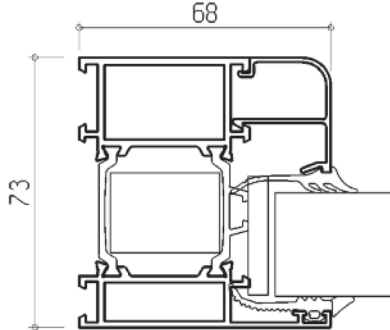

TRASMITTANZA TERMICA COMPLESSIVA

ESEMPI di CALCOLO SU:
 FINESTRA 1 ANTA DIM. 1230x1480 mm

U WINDOW= 1.47 W/m^2K
 VETRO UG= 1.1 W/mK
 VALORE PSI 0.11



U WINDOW= 1.63 W/m^2K
 VETRO UG= 1.3 W/mK
 VALORE PSI 0.11

TRASMITTANZA TERMICA UNITARIA $U_{Frame} = 1.62 W/(m^2.K)$

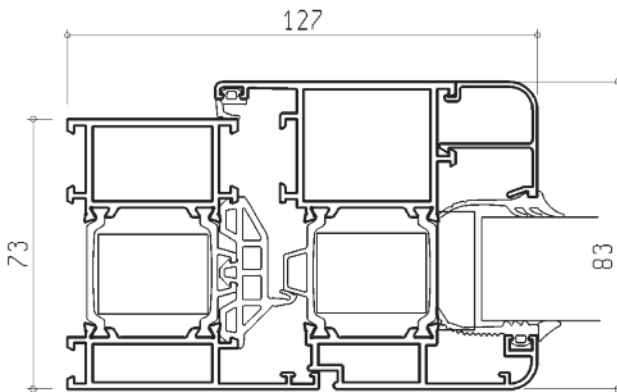

TRASMITTANZA TERMICA COMPLESSIVA

ESEMPI di CALCOLO SU:
 FINESTRA 1 ANTA DIM. 1230x1480 mm

U WINDOW= 1.54 W/m^2K
 VETRO UG= 1.1 W/mK
 VALORE PSI 0.11



U WINDOW= 1.68 W/m^2K
 VETRO UG= 1.3 W/mK
 VALORE PSI 0.11

TRASMITTANZA TERMICA UNITARIA $U_{Frame} = 1.48 W/(m^2.K)$

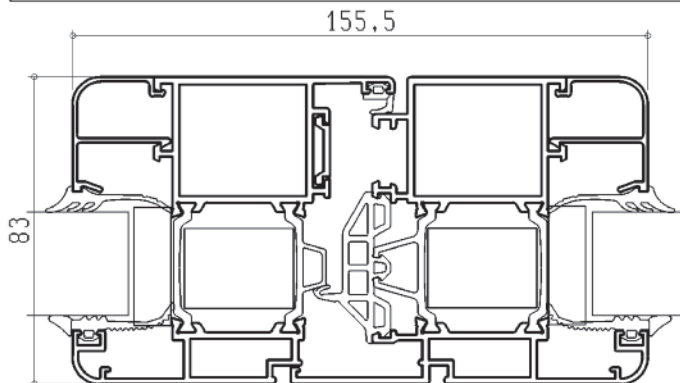

TRASMITTANZA TERMICA COMPLESSIVA

ESEMPIO di CALCOLO SU:
 FINESTRA 2 ANTE DIM. 1230x1480 mm

U WINDOW
1.55 W/m^2K
 VETRO UG= 1.0 W/mK
 VALORE PSI 0.08
 (WARM EDGE)

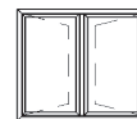

U WINDOW
1.77 W/m^2K
 VETRO UG= 1.2 W/mK
 VALORE PSI 0.11

TRASMITTANZA TERMICA UNITARIA $U_{Frame} = 1.51 W/(m^2.K)$

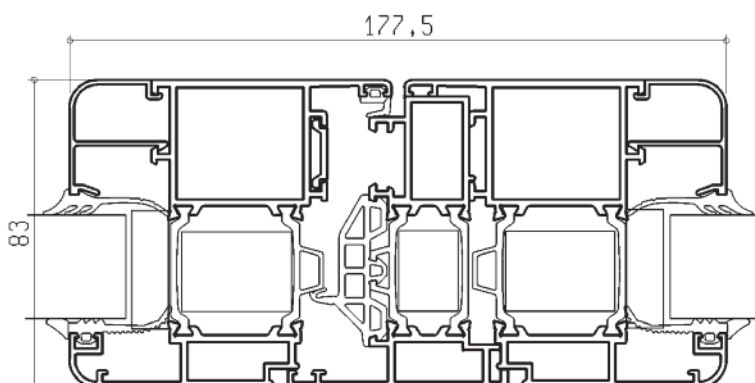

TRASMITTANZA TERMICA COMPLESSIVA

ESEMPIO di CALCOLO SU:
 FINESTRA 2 ANTE DIM. 1230x1480 mm

U WINDOW
1.56 W/m^2K
 VETRO UG= 1.0 W/mK
 VALORE PSI 0.08
 (WARM EDGE)



U WINDOW
1.77 W/m^2K
 VETRO UG= 1.2 W/mK
 VALORE PSI 0.11

PRESTAZIONI TERMICHE IN RISPETTO AL DM 26 GENNAIO 2010
VALIDE PER TUTTE LE LINEE ESTETICHE (ZONE E-F)

TRASMITTANZA TERMICA UNITARIA $U_{Frame} = 1.55 W/(m^2.K)$

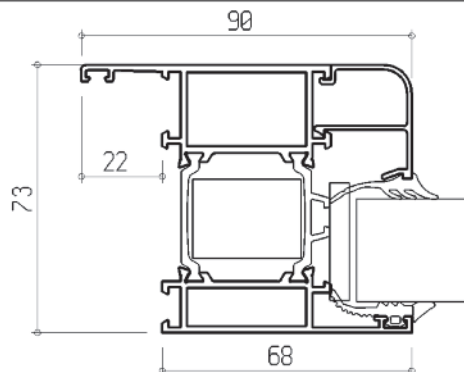

TRASMITTANZA TERMICA COMPLESSIVA

ESEMPI di CALCOLO SU:

FINESTRA 1 ANTA DIM. 1230x1480 mm

U WINDOW
1.48 W/m^2K

VETRO UG- 1.1 W/mK
VALORE PSI 0.11



U WINDOW
1.64 W/m^2K

VETRO UG- 1.3 W/mK
VALORE PSI 0.11

TRASMITTANZA TERMICA UNITARIA $U_{Frame} = 1.68 W/(m^2.K)$

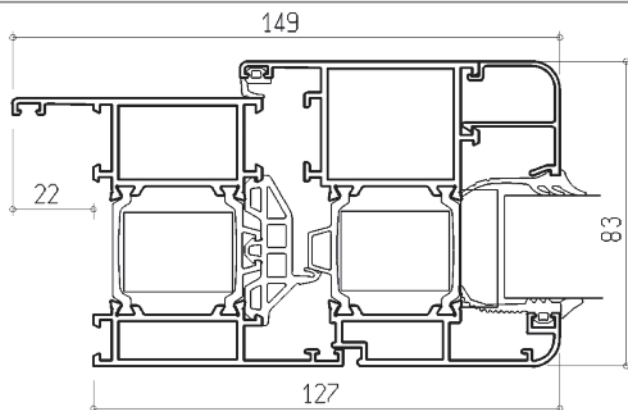

TRASMITTANZA TERMICA COMPLESSIVA

ESEMPI di CALCOLO SU:

FINESTRA 1 ANTA DIM. 1230x1480 mm

U WINDOW
1.56 W/m^2K

VETRO UG- 1.1 W/mK
VALORE PSI 0.11



U WINDOW
1.70 W/m^2K

VETRO UG- 1.3 W/mK
VALORE PSI 0.11

TRASMITTANZA TERMICA UNITARIA $U_{Frame} = 1.57 W/(m^2.K)$

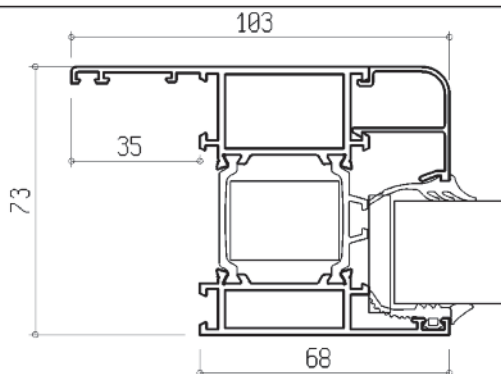

TRASMITTANZA TERMICA COMPLESSIVA

ESEMPI di CALCOLO SU:

FINESTRA 1 ANTA DIM. 1230x1480 mm

U WINDOW
1.49 W/m^2K

VETRO UG- 1.1 W/mK
VALORE PSI 0.11



U WINDOW
1.65 W/m^2K

VETRO UG- 1.3 W/mK
VALORE PSI 0.11

TRASMITTANZA TERMICA UNITARIA $U_{Frame} = 1.70 W/(m^2.K)$

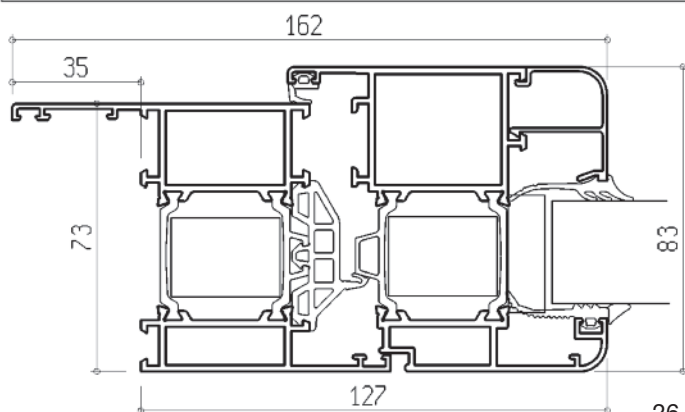

TRASMITTANZA TERMICA COMPLESSIVA

ESEMPI di CALCOLO SU:

FINESTRA 1 ANTA DIM. 1230x1480 mm

U WINDOW
1.57 W/m^2K

VETRO UG- 1.1 W/mK
VALORE PSI 0.11



U WINDOW
1.70 W/m^2K

VETRO UG- 1.3 W/mK
VALORE PSI 0.11

TRASMITTANZA TERMICA UNITARIA

VALIDE PER TUTTE
LE LINEE ESTETICHE

VALORI UF NODI

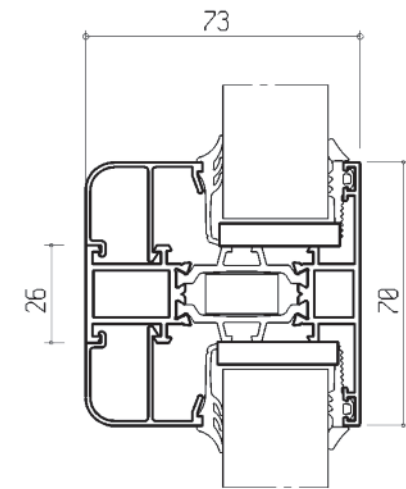

KK.83010

TRASMITTANZA
TERMICA
UNITARIA
U Frame
1.44 W/(m²K)

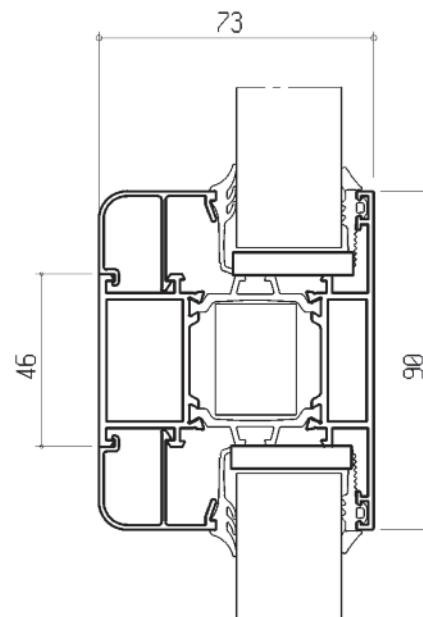

KK.83014

TRASMITTANZA
TERMICA
UNITARIA
U Frame
1.31 W/(m²K)

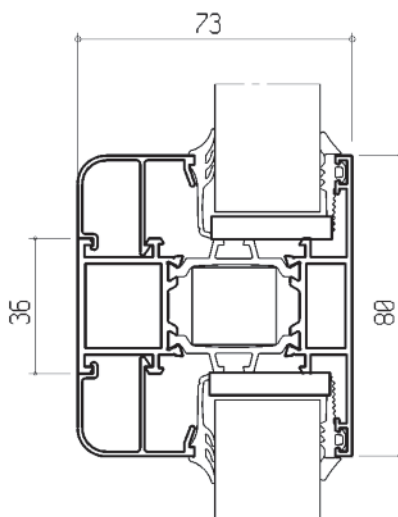

KK.83012

TRASMITTANZA
TERMICA
UNITARIA
U Frame
1.37 W/(m²K)

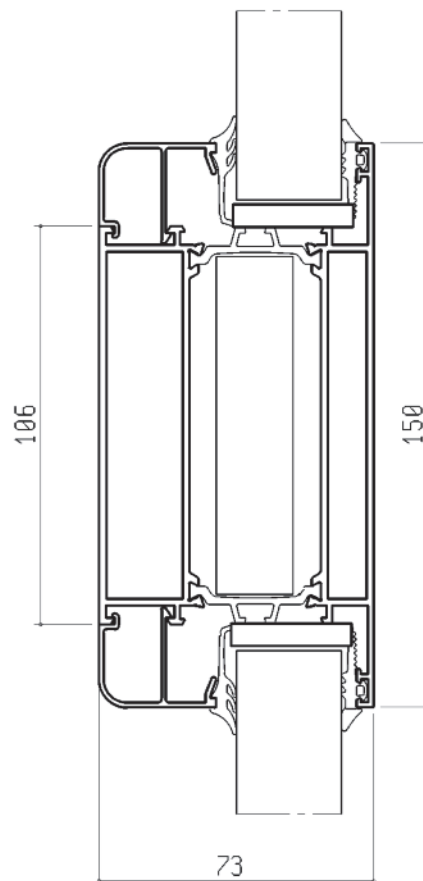

KK.83019

TRASMITTANZA
TERMICA
UNITARIA
U Frame
1.11 W/(m²K)

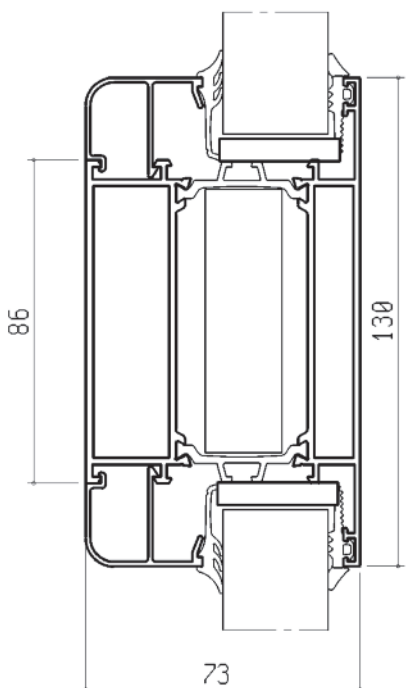

KK.83016

TRASMITTANZA
TERMICA
UNITARIA
U Frame
1.16 W/(m²K)

TRASMITTANZA TERMICA UNITARIA

VALIDE PER TUTTE
LE LINEE ESTETICHE

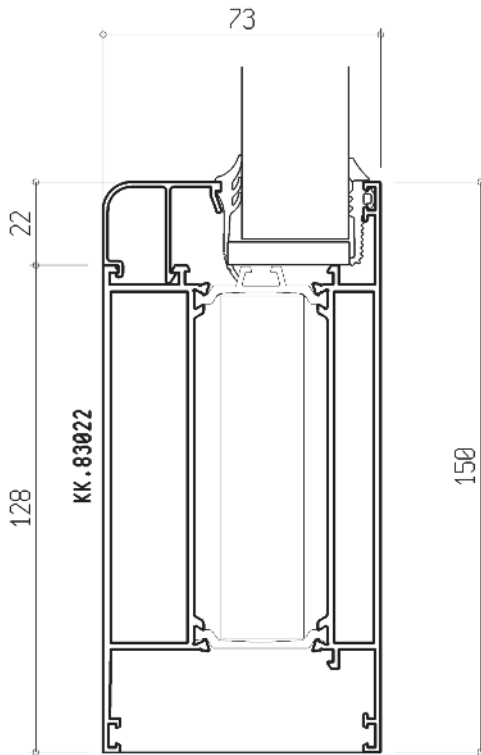

VALORI UF NODI

Valore Uf nodo
zoccolo

TRASMITTANZA TERMICA UNITARIA

$$U_{Frame} = 1.67 \text{ W}/(\text{m}^2 \cdot \text{K})$$

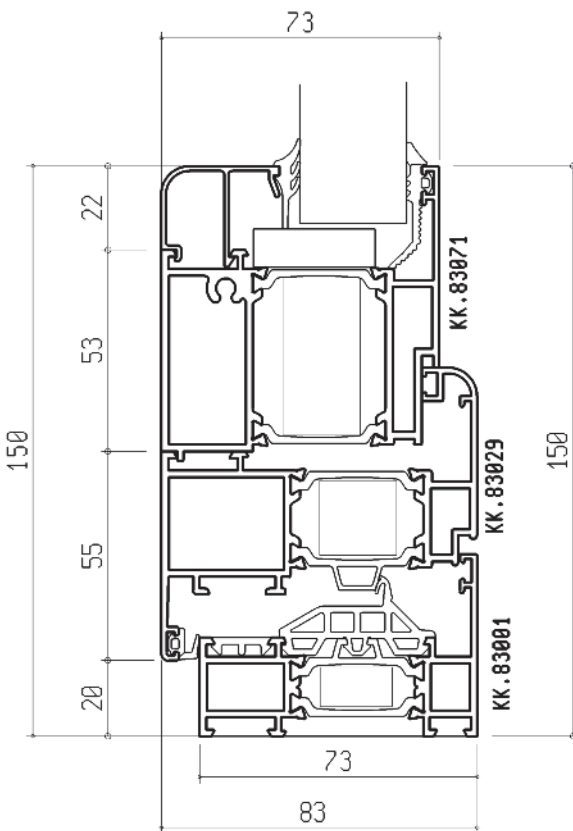

Valore Uf nodo
soglia con zoccolo riportato

TRASMITTANZA TERMICA UNITARIA

$$U_{Frame} = 1.87 \text{ W}/(\text{m}^2 \cdot \text{K})$$

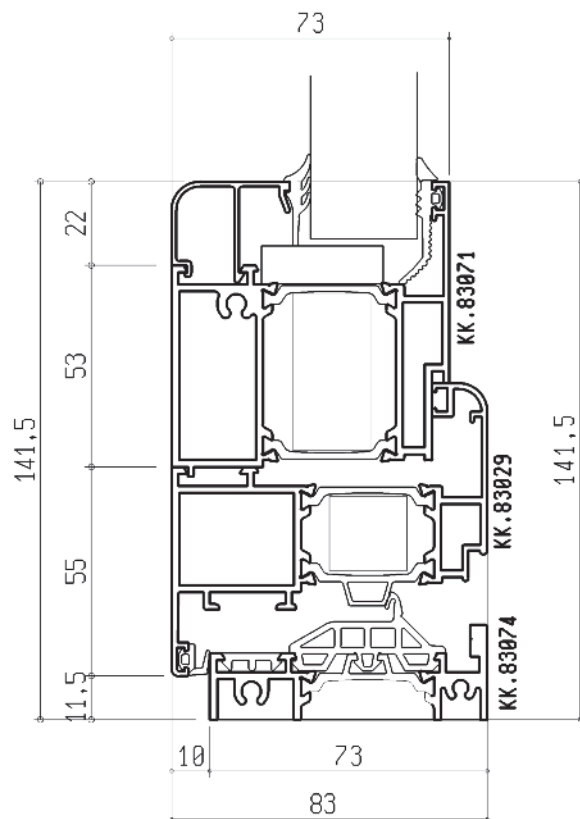

Valore Uf nodo
soglia ribassata e zoccolo riportato

TRASMITTANZA TERMICA UNITARIA

$$U_{Frame} = 1.96 \text{ W}/(\text{m}^2 \cdot \text{K})$$

TRASMITTANZA TERMICA UNITARIA

VALIDE PER TUTTE
LE LINEE ESTETICHE

VALORI UF NODI

TRASMITTANZA TERMICA UNITARIA

$$U_{Frame} = 2.41 \text{ W}/(\text{m}^2 \cdot \text{K})$$

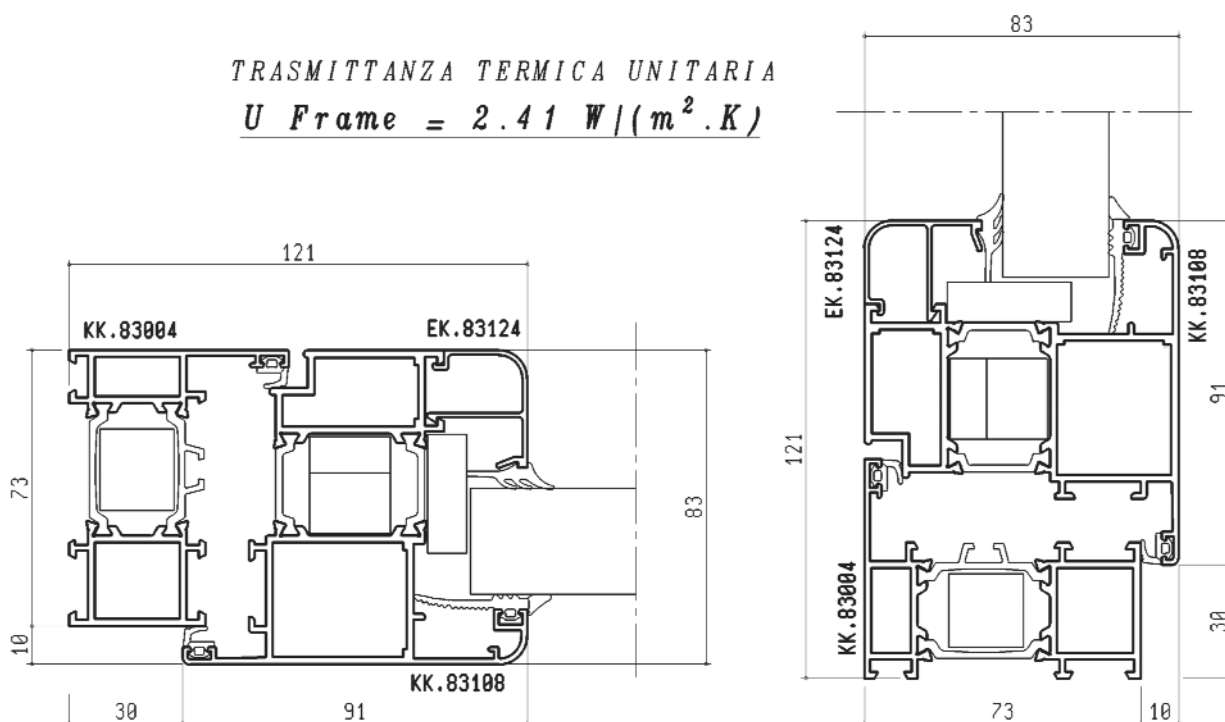

TRASMITTANZA TERMICA COMPLESSIVA

PRESTAZIONI TERMICHE IN RISPETTO AL DM 26 GENNAIO 2010
(ZONE E - F)

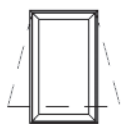

Prospetto visto
dall'esterno

ESEMPIO di CALCOLO SU : FINESTRA 1 ANTA DIM 1230x1480

VETRO UG= 0.9 W/mK

VALORE PSI 0.08
(WARM EDGE)

VALORE UW_2
1,59 W/(m² K)



Prospetto visto
dall'esterno

ESEMPIO di CALCOLO SU : FINESTRA 1 ANTA DIM 1230x1480

VETRO UG= 1.1 W/mK

VALORE PSI 0.11

VALORE UW_2
1,80 W/(m² K)

VALIDO PER TUTTE LE LINEE ESTETICHE

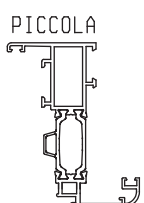
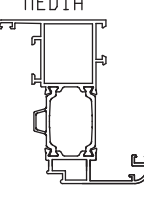
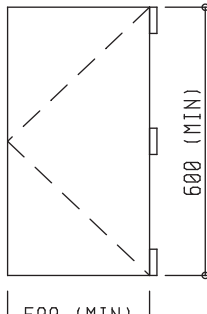
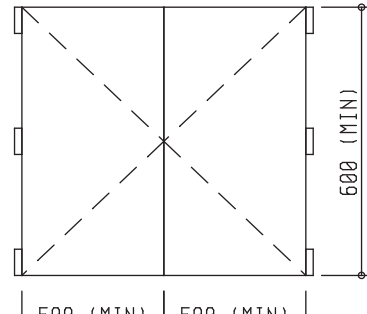
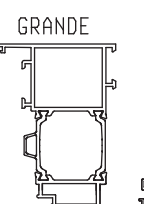
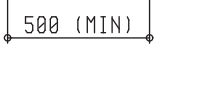
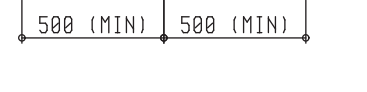
DIMENSIONAMENTO FINESTRA 1 ANTA E 2 ANTE				
PROFILO	PESO MAX ANTA	DIMENSIONI MINIMA ANTA		Q.TA' CERNIERE PER ANTA
		FINESTRA 1 ANTA	FINESTRA 2 ANTE	
PICCOLA 	80 kg			2
MEDIA 	100 kg			2/3
GRANDE 	120 kg			3

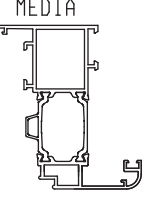
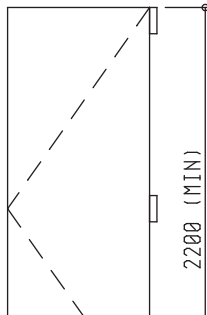
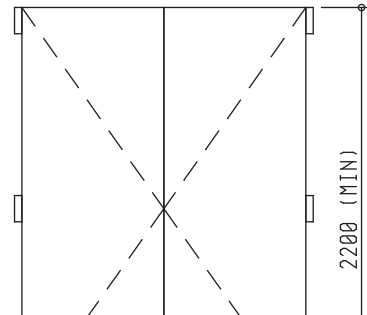
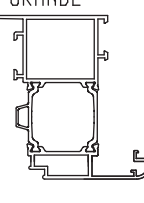
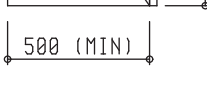
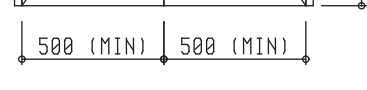
DIMENSIONAMENTO PORTA-FINESTRA 1 ANTA E 2 ANTE				
PROFILO	PESO MAX ANTA	DIMENSIONI MINIMA ANTA		Q.TA' CERNIERE PER ANTA
		PORTA-FINESTRA 1 ANTA	PORTA-FINESTRA 2 ANTE	
MEDIA 	100 kg			2/3
GRANDE 	120 kg			3

ACCESSORI E GUARNIZIONI

- *Sagomario accessori
con codici, descrizioni e dati tecnici
relativi (Schede EA)*
- *Sagomario guarnizioni
con codici, descrizioni e dati tecnici
relativi (Schede EG)*

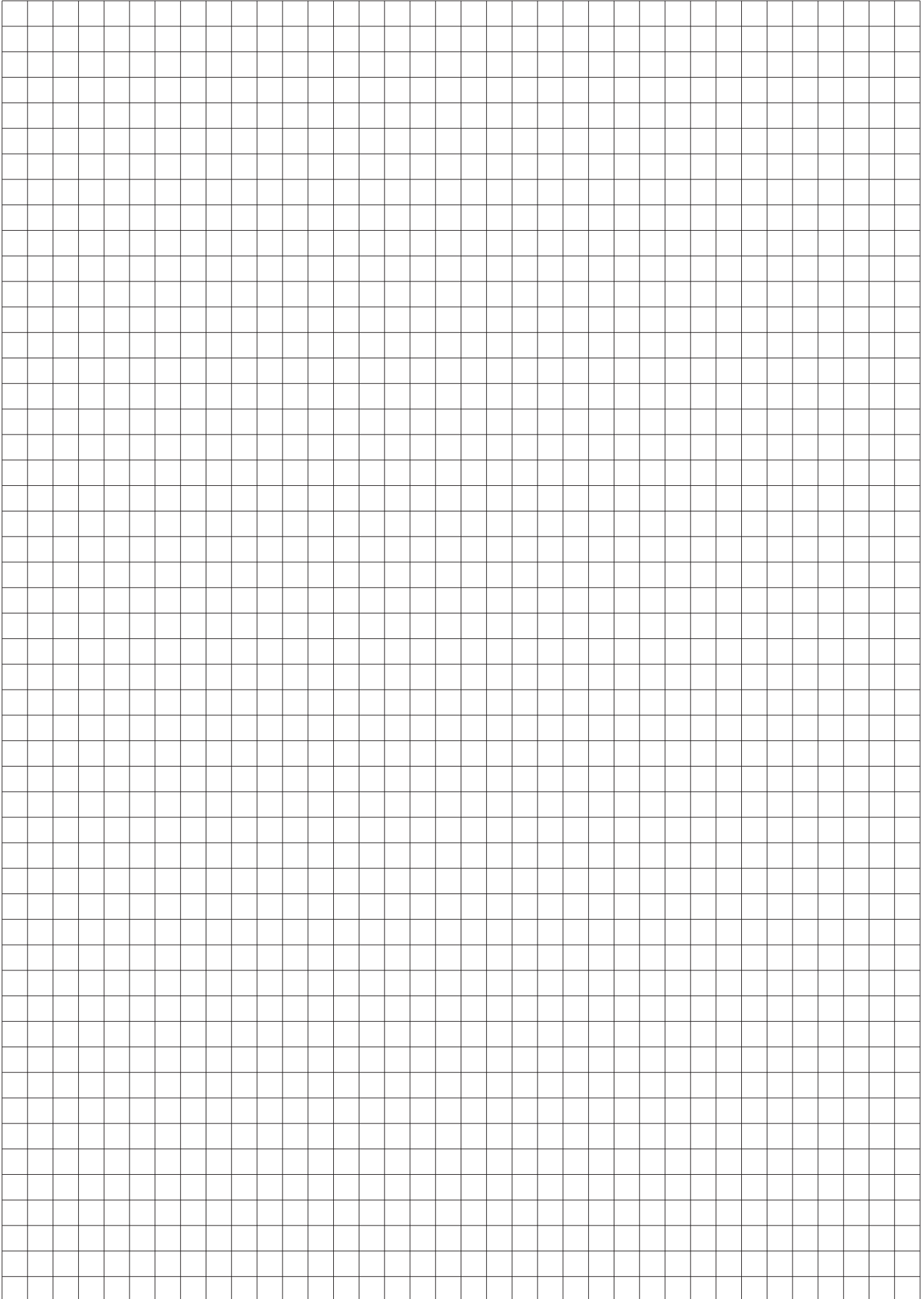

AK.83701

Squadretta interna
per telai fissi da 26 mm



AK.83706

Squadretta interna
per ante da 65 mm

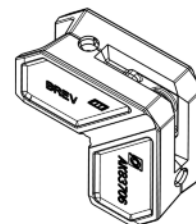

AK.83702

Squadretta interna
per telai fissi da 36 mm

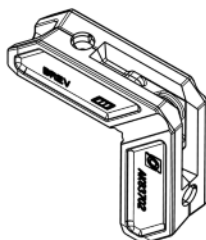

AK.83707

Squadretta interna
per telai fissi da 26 mm

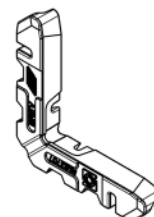

AK.83703

Squadretta interna
per telai fissi da 46 mm

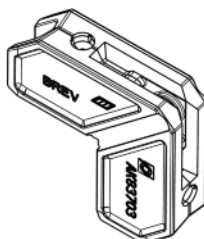

AK.83708

Squadretta interna
per telai fissi da 36 mm

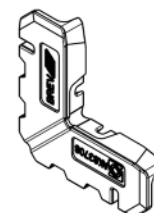

AK.83704

Squadretta interna
per ante da 45 mm

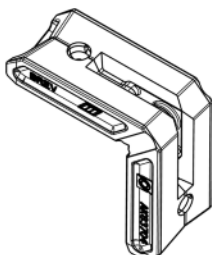

AK.83709

Squadretta interna
per telai fissi da 46 mm

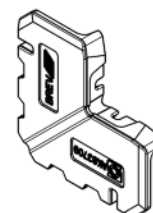

AK.83705

Squadretta interna
per ante da 55 mm

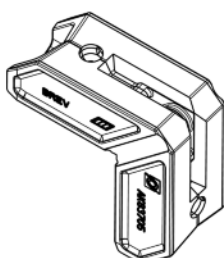

AK.83710

Squadretta esterna
per ante da 45 mm

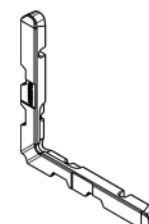

AK.83711

Squadretta esterna
per ante da 55 mm

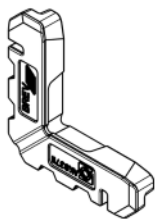

AK.83720

Cavallotto interno
per fascia KK.83012



AK.83712

Squadretta esterna
per ante da 65 mm

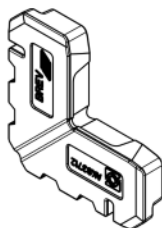

AK.83721

Cavallotto interno
per fasce e zoccoli



AK.83717

Cavallotto interno
per fascia KK.83010



AK.83722

Cavallotto esterno
per fasce e zoccoli

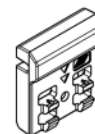

AK.83718

Squadretta di allineamento
per tutti i telai

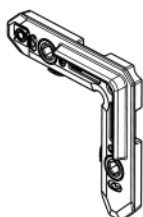

AK.83725

Squadretta di allineamento
per ante

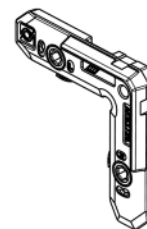

AK.83719

Cavallotto interno
per fascia KK.83012



AK.83729

Squadretta interna
per anta a sporgere

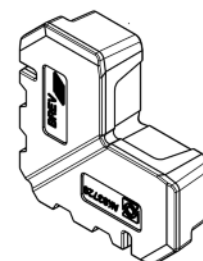

AK. 83729

Squadretta interna
per telaio mobile a sporgere
KK.83108

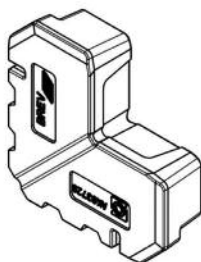

AK. 73714

Viti
Confezione da 100 pz.



AK. 73715

Spine
Confezione da 100 pz.



AK. 90029 Alluminio

AK. 94139 Nylon

Squadretta di allineamento



AK. 94028

Squadretta di allineamento
per imbotti



AK. 94029

Squadretta per imbotte su
EK.15788, EK.15817 e EK.15876

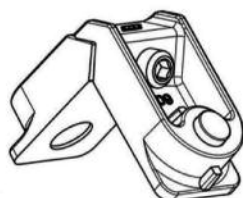

AK.83803

Spessore per fissi

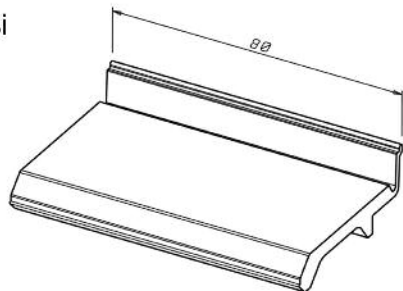

Materiale: Polipropilene Nero

AK.83804

Spessore per apribili

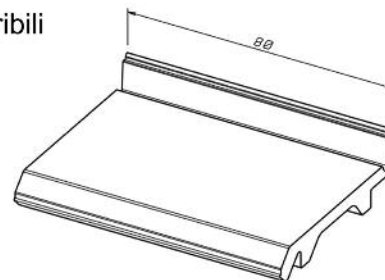

Materiale: Polipropilene Marrone

Kit AK.83813

Tappi per T/Z ante, aperture interne

Composto dalle seguenti coppie di articoli:

AK.83813I



AK.83813C

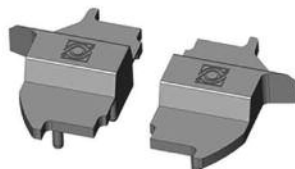

AK.83813E



Materiale: Poliammide

AK.83814R / M

Tappi per battuta centrale riportata complanare

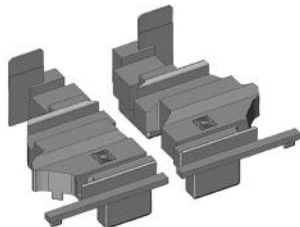

Materiale: Poliammide / EPDM

La coppia

AK.83815R / M

Tappi per battuta centrale riportata
Soluzione Tonda

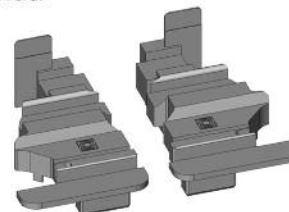

Materiale: Poliammide / EPDM

La coppia

AK.83816R / M

Tappi per battuta centrale riportata
Soluzione Smussata

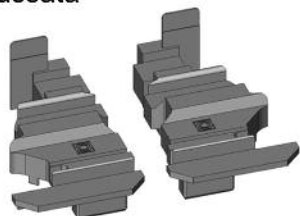

Materiale: Poliammide / EPDM

La coppia

AK.83817R / M

Tappi per battuta centrale riportata
Soluzione Concava

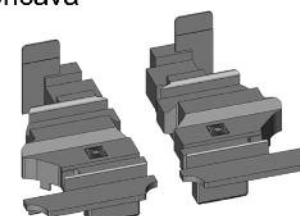

Materiale: Poliammide / EPDM

La coppia

AK.83818R / M

Tappi per battuta centrale riportata
Soluzione Evoluzione

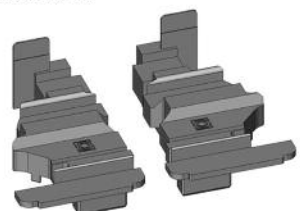

Materiale: Poliammide / EPDM

La coppia

AK.83800

Angolo pressofuso
Soluzione Smussata

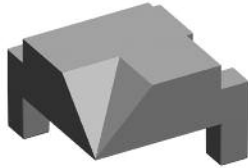

AK.83801

Angolo pressofuso
Soluzione Concava

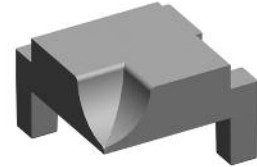

AK.83802

Angolo pressofuso
Soluzione Evoluzione

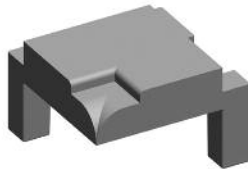

AK.93559

Angolo pressofuso
Soluzione Tonda

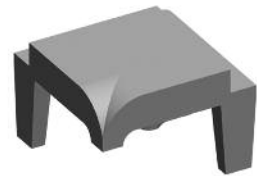

AK.93540

Tappo laterale per gocciolatoio

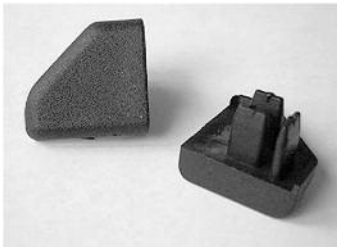

AK.73802

Distanziatore per alluminio

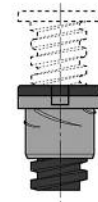

Materiale: corpo in zama

FRESE COMALL

FDX30652

Intestatura telaio mobile "Z" KK.73004

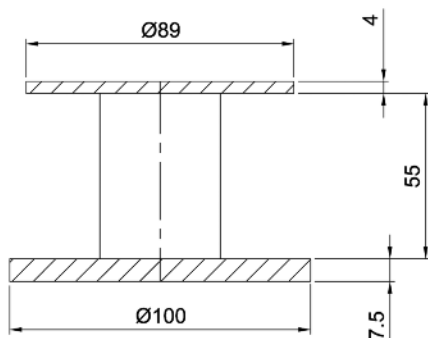

SL13

FDX30653

Intestatura telai mobili "T" KK.73007

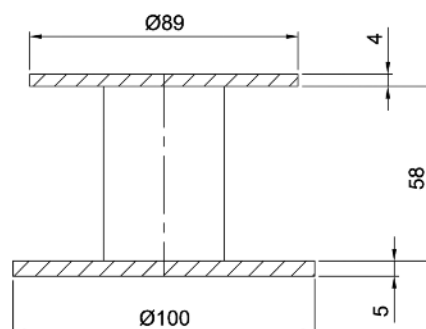

SL13

FDX30654

Intestatura soglie KK.73026 e KK.73029, riporto per zoccolo KK.73023, fasce e zoccoli per soluzione con tappi

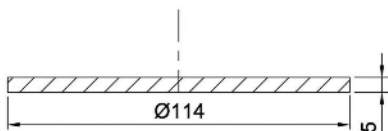

SL07

FDX30657

Intestatura fasce e zoccolo

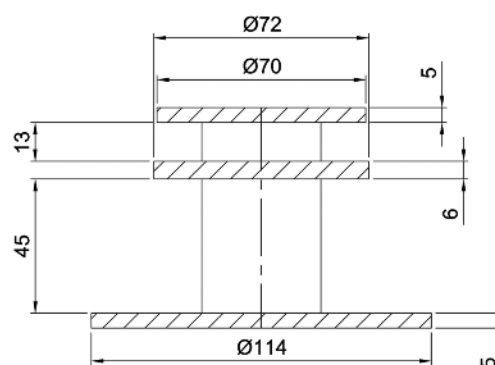

SL07 - SL08 - SL09

FDX30658

Intestatura riporto per zoccolo KK.73023 lavorazione 1.5 mm per aperture interne

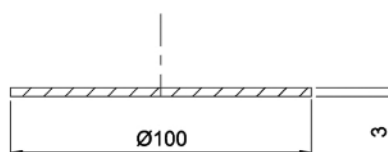

SL10 - SL11

FDX30656

Intestatura fascia KK.83132

Intestatura zoccolo riportato KK.83134

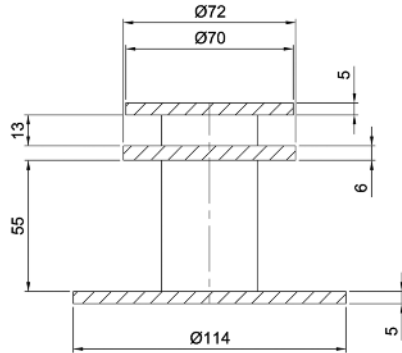

SLG1 - SLG2

ZPX14372

Punzonatrice

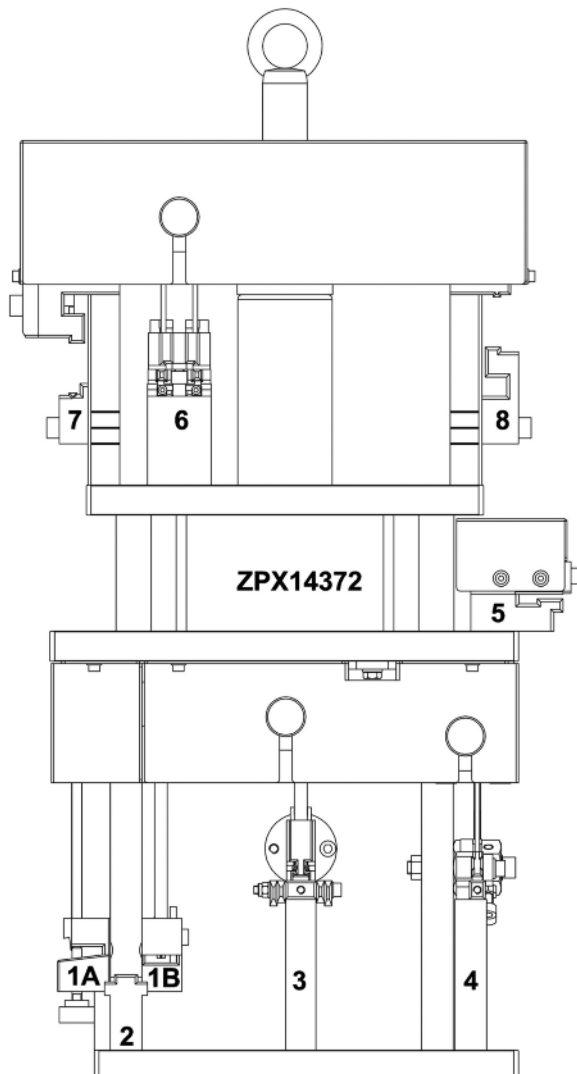

- Stazione 1A = CREMONESE
- Stazione 1B = FORATURA ASTA
- Stazione 2 = SPUNTATURA DENTINI
- Stazione 3 = SQUADRETTE E CAVALLOTTI DIAM. 8 mm
- Stazione 4 = SQUADRETTE E CAVALLOTTI DIAM. 3 mm
- Stazione 5 = SCARICO ACQUA
- Stazione 6 = SQUADRETTE DIAM. 3 PER ANTE
- Stazione 7 = SCARICO CONDENSA INTERNO
- Stazione 8 = SCARICO CONDENSA ESTERNO

PEDALIERA
Codice GPX30081



GK.83551

Fermavetro esterno coestruso 4 mm

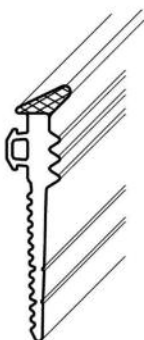

Materiale: EPDM 70SH + ESP.

GK.83552

Fermavetro interno aria 3 - 4.5 mm



Materiale: EPDM 70SH

GK.83553

Fermavetro interno aria 5 - 7

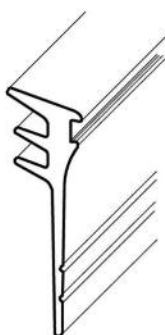

Materiale: EPDM 70SH

GK.83554

Battuta finestre coestrusa

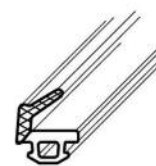

Materiale: EPDM 70SH + ESP.

GK.83555

Battuta centrale

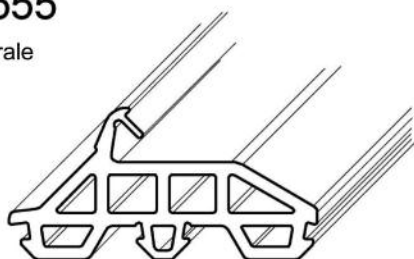

Materiale: EPDM 60SH

GK.83556

Angolo per battuta centrale

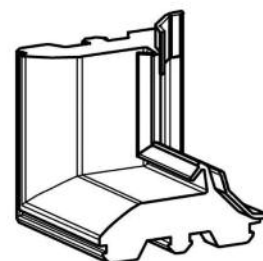

Materiale: EPDM 60SH

GK.83557

Guarnizione riporta filo per "camera europea"

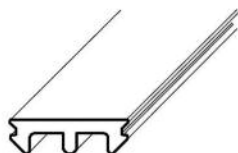

Materiale: EPDM 80SH

GK.83559

Guarnizione perimetrale di battuta

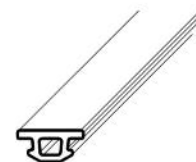

Materiale: EPDM 70SH

GK.83560

Guarnizione soglia

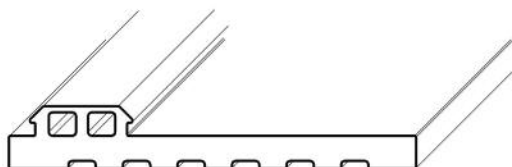

Materiale: EPDM 90SH

DATA	SCHEDA
Maggio 2016	EG02

GK.80157 * = mm 3 - 5

Guarnizione per compensatore

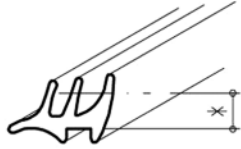

GK.80216 * = mm 5

Guarnizione per compensatore

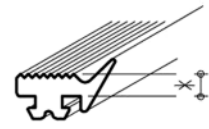

GK.80203

Guarnizione per profili
di dilatazione/nastro

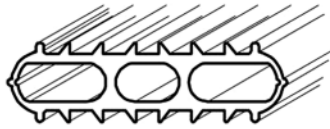

GK.80353

Guarnizione per profili
di dilatazione/nastro

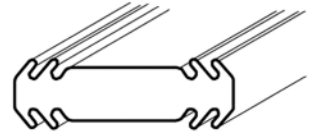

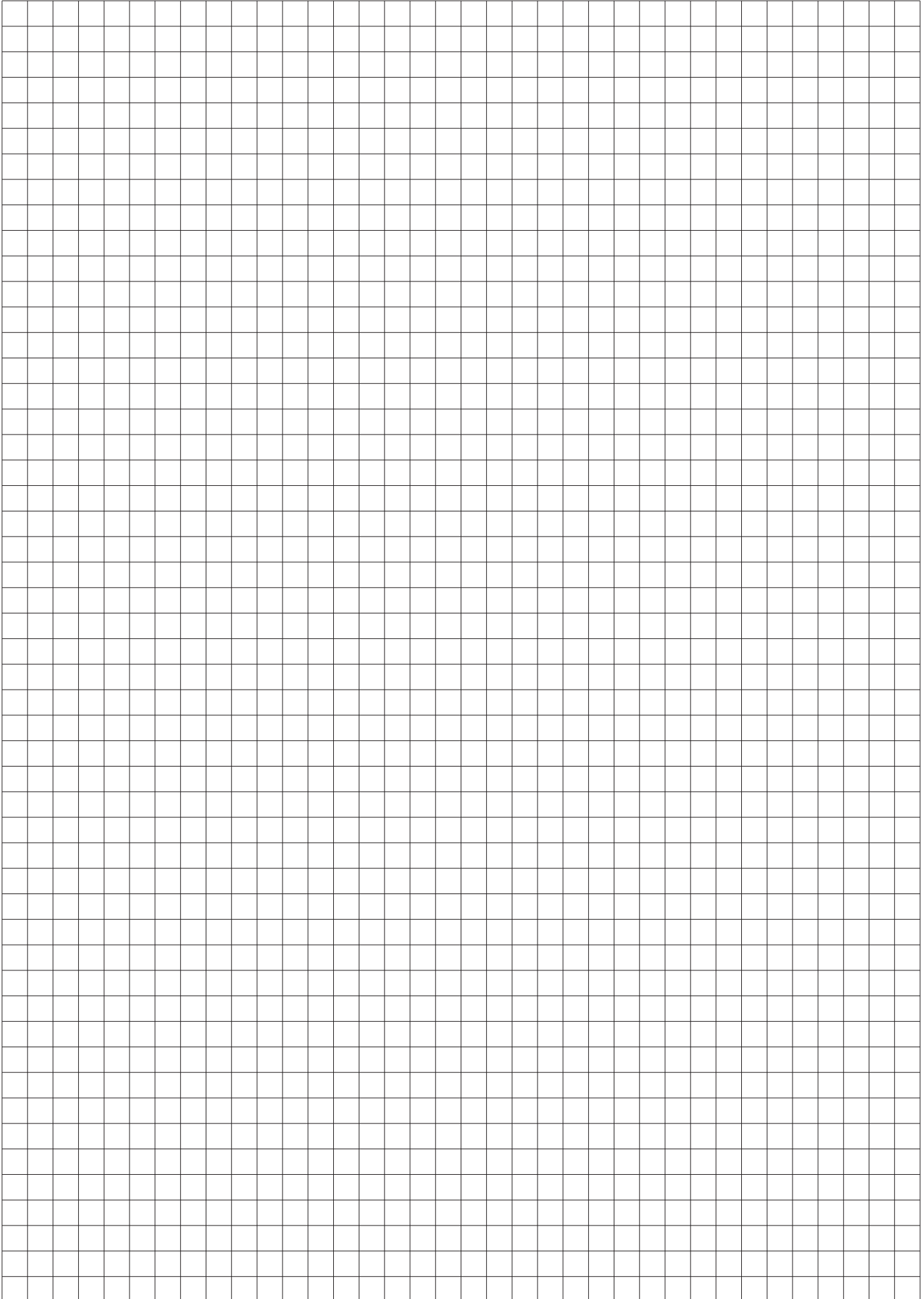



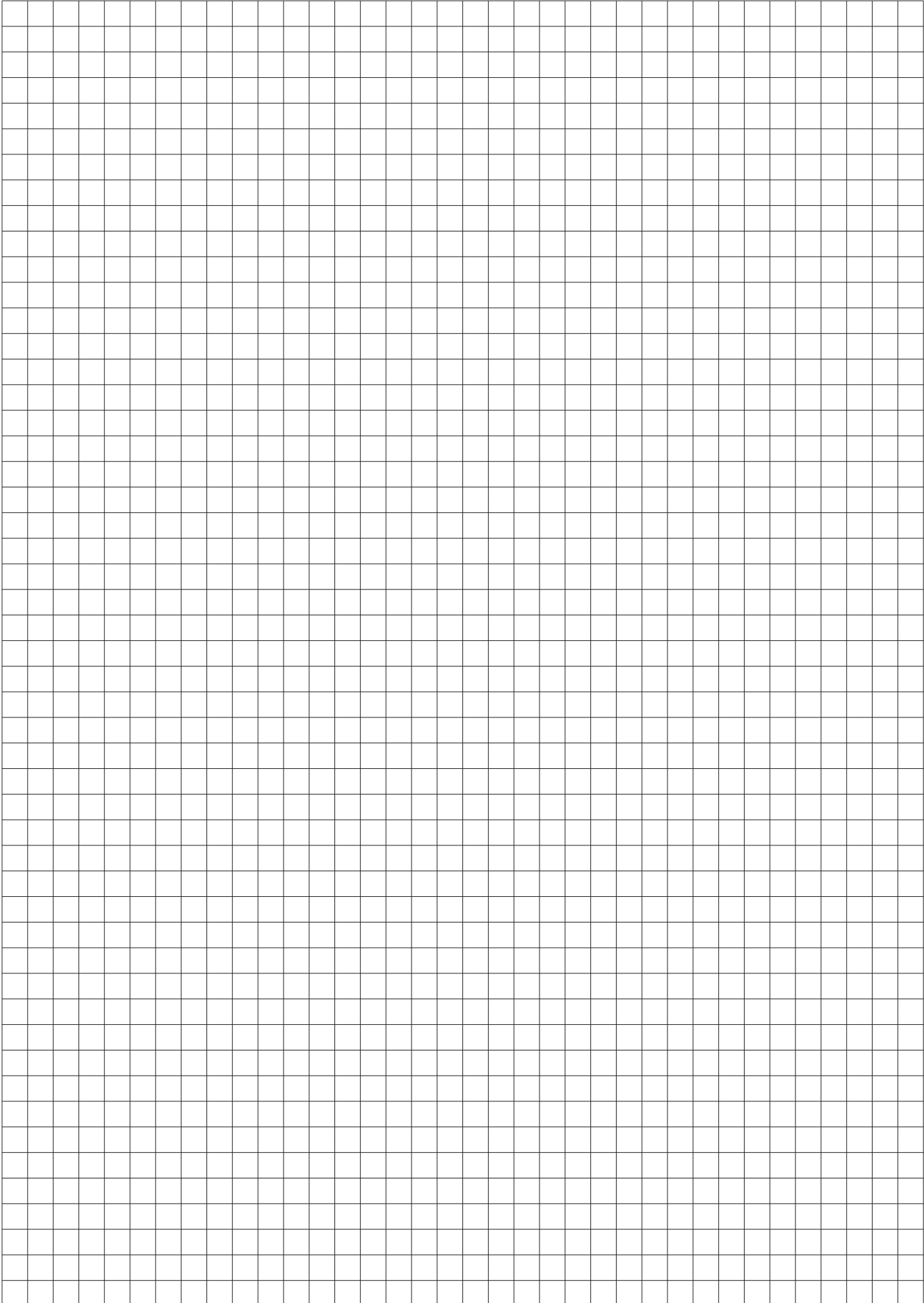

SAGOMARIO PROFILATI

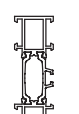
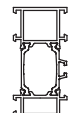
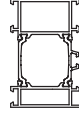
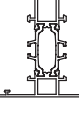
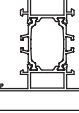
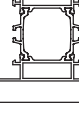
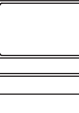
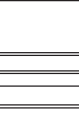
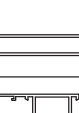
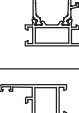
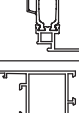
- *Sagomario profilati
con descrizioni e dati tecnici (Schede CP)*



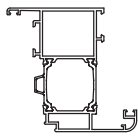
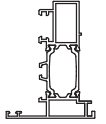
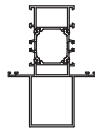
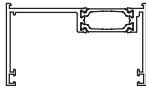
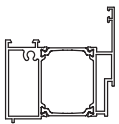
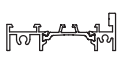
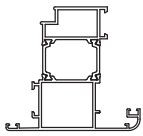
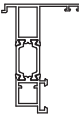
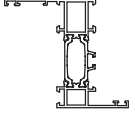
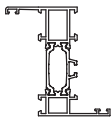
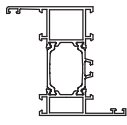



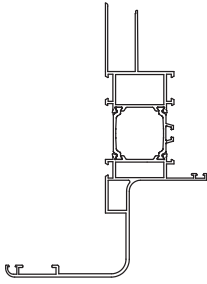
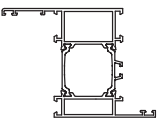
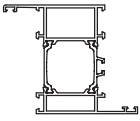
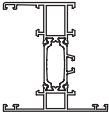
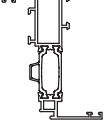
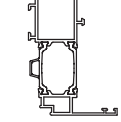





CODICE	SAGOMA 	PESO Kg/m	DESIGNAZIONE	Perimetro esterno mm	Perimetro in vista mm	Scheda	Jx cm ⁴	Wx cm ³
							Jy cm ⁴	Wy cm ³
KK.83001		1.344	TELAIO FISSO "L" 26/48 mm	346	79	SP01	31.13	9.25
							4.73	3.03
KK.83004		1.553	TELAIO FISSO "L" 36/58 mm	367	99	SP01	37.30	11.02
							9.31	4.52
KK.83007		1.754	TELAIO FISSO "L" 46/68 mm	387	119	SP02	43.42	12.77
							16.31	3.36
KK.83010		1.487	TELAIO FISSO "T" FASCIA 26/70 mm	404	105	SP02	35.00	11.38
							7.96	2.28
KK.83012		1.694	TELAIO FISSO "T" FASCIA 36/80 mm	424	125	SP03	41.28	13.17
							13.76	3.45
KK.83014		1.894	TELAIO FISSO "T" FASCIA 46/90 mm	445	145	SP03	47.48	15.02
							22.17	4.92
KK.83016		2.694	FASCIA 86/130 mm (TELAIO FISSO "T")	524	225	SP04	72.05	22.06
							89.47	13.80
KK.83019		3.093	FASCIA 106/150 mm (TELAIO FISSO "T")	564	265	SP05	84.32	39.87
							148.61	14.03
KK.83022		3.146	ZOCCOLO 128/150 mm	604	287	SP06	90.33	26.15
							164.29	22.55
KK.83024		1.740	TELAIO FISSO "Z" 71/58 mm BATTUTA DA 35 mm COMPLANARE	461	138	SP09	46.00	11.74
							19.28	3.80
KK.83026		1.544	TELAIO MOBILE "Z" 45/35 mm	438	113	SP09	46.50	10.66
							9.75	2.86
KK.83029		1.760	TELAIO MOBILE "Z" 55/45 mm	454	132	SP11	54.93	12.89
							16.30	4.18

CODICE	SAGOMA 	PESO Kg/m	DESIGNAZIONE	Perimetro esterno mm	Perimetro in vista mm	Scheda	Jx cm ⁴	Wx cm ³
							Jy cm ⁴	Wy cm ³
KK.83032		1.960	TELAIO MOBILE "Z" 65/55 mm	474	151	SP11	62.81	14.94
							25.67	5.83
KK.83035		1.490	BATTUTA CENTRALE RIPORTATA COMPLANARE	367	84	SP12	30.37	11.12
							7.50	2.12
KK.83098		2.632	TELAIO FISSO "T" 46/125 mm RINFORZATO	548	136	SP15	135.83	21.45
							32.60	7.24
KK.83100		1.727	PROFILO COMPENSATORE TERMICO FISSO	478	122	SP16	14.73	4.09
							81.26	16.92
KK.83071		1.933	ZOCCOLO RIPORTATO	362	111	SP14	23.21	7.18
							47.88	12.94
KK.83074		0.996	SOGLIA RIDOTTA GIUNTO APERTO	320	50	SP12	0.90	0.84
							24.35	6.08
KK.83108		2.114	ANTA PER SPORGERE	485	165	SP13	62.02	17.53
							29.84	6.58
KK.83111		1.253	INVERSIONE BATTUTA PER SPORGERE	305	61	SP13	26.50	6.26
							4.49	2.18
KK.83177		1.532	TELAIO FISSO "Z" 61/48 mm CON ALETTA DI BATTUTA COMPLANARE DA 35 mm	468	118	SP07	39.70	10.13
							11.33	2.70
KK.83194		1.462	TELAIO FISSO "Z" 48/48 mm CON ALETTA DI BATTUTA COMPLANARE DA 22 mm	430	105	SP07	36.84	9.87
							7.92	2.26
KK.83200		1.672	TELAIO FISSO "Z" 58/58 mm CON ALETTA DI BATTUTA COMPLANARE DA 22 mm	453	126	SP08	43.07	11.65
							13.75	3.72

CODICE	SAGOMA 	PESO Kg/m	DESIGNAZIONE	Perimetro esterno mm	Perimetro in vista mm	Scheda	Jx cm ⁴	Ux cm ³
							Jy cm ⁴	Wy cm ³
KK.83209		3.165	TELAIO IMBOTTE	916	266	SP18	308.70	39.53
							73.20	9.53
KK.83216		1.943	TELAIO FISSO "Z" 81/68 mm CON ALETTA DI BATTUTA COMPLANARE DA 35 mm	471	158	SP10	52.17	13.70
							29.00	5.30
KK.83249		1.672	TELAIO FISSO "Z" 68/68 mm CON ALETTA DI BATTUTA COMPLANARE DA 22 mm	471	126	SP10	49.33	13.55
							22.35	5.00
KK.83261		1.569	TELAIO FISSO "H" 48/70 mm	425	132	SP08	41.72	12.23
							10.73	3.35
KK.83150		1.469	TELAIO MOBILE "Z" DA45/35	530	109	SP18	43.05	9.38
							7.25	2.25
KK.83055		1.685	TELAIO MOBILE "Z" DA55/45	619	121	SP18	52.22	11.81
							11.92	3.47

FERMAVETRI E FERMAPANNELLI

CODICE	SAGOMA 	PESO Kg/m	DESIGNAZIONE	Perimetro esterno mm	Perimetro in vista mm	Scheda	Jx cm ⁴	Wx cm ³
							Jy cm ⁴	Wy cm ³
EK.13086		0.275	FERMAVETRO DA 23 mm CON CAVA PORTAGOMMA	174	41	SP19		
EK.16102		0.285	FERMAVETRO DA 27 mm CON CAVA PORTAGOMMA	176	45	SP19		
EK.13087		0.296	FERMAVETRO DA 31 mm CON CAVA PORTAGOMMA	185	49	SP19		
EK.13097		0.285	FERMAVETRO DA 23 mm CON CAVA PORTAGOMMA	179	44	SP19		
EK.16101		0.295	FERMAVETRO DA 27 mm CON CAVA PORTAGOMMA	183	48	SP20		
EK.13096		0.299	FERMAVETRO DA 31 mm CON CAVA PORTAGOMMA	185	52	SP20		
9097		0.308	FERMAVETRO DA 35 mm CON CAVA PORTAGOMMA	192	56	SP20		
9175		0.318	FERMAVETRO DA 40 mm CON CAVA PORTAGOMMA	201	61	SP20		
EK.14505		0.299	GOCCIOLATOIO	130	32	SP21		
EK.16588		0.470	SCIVOLO PER SOGLIA RIBASSATA	174	50	SP21		
EK.83170		0.289	ALETTA DI BATTUTA COMPLANARE DA 35 mm	143	40	SP22		
EK.83262		0.471	ALETTA DI BATTUTA COMPLANARE DA 70 mm	178	75	SP22		

SEZIONI PROFILATI

- *Disegni in scala 1:1
di tutti i profilati del sistema
completi di peso e perimetro in vista
(Schede SP)*

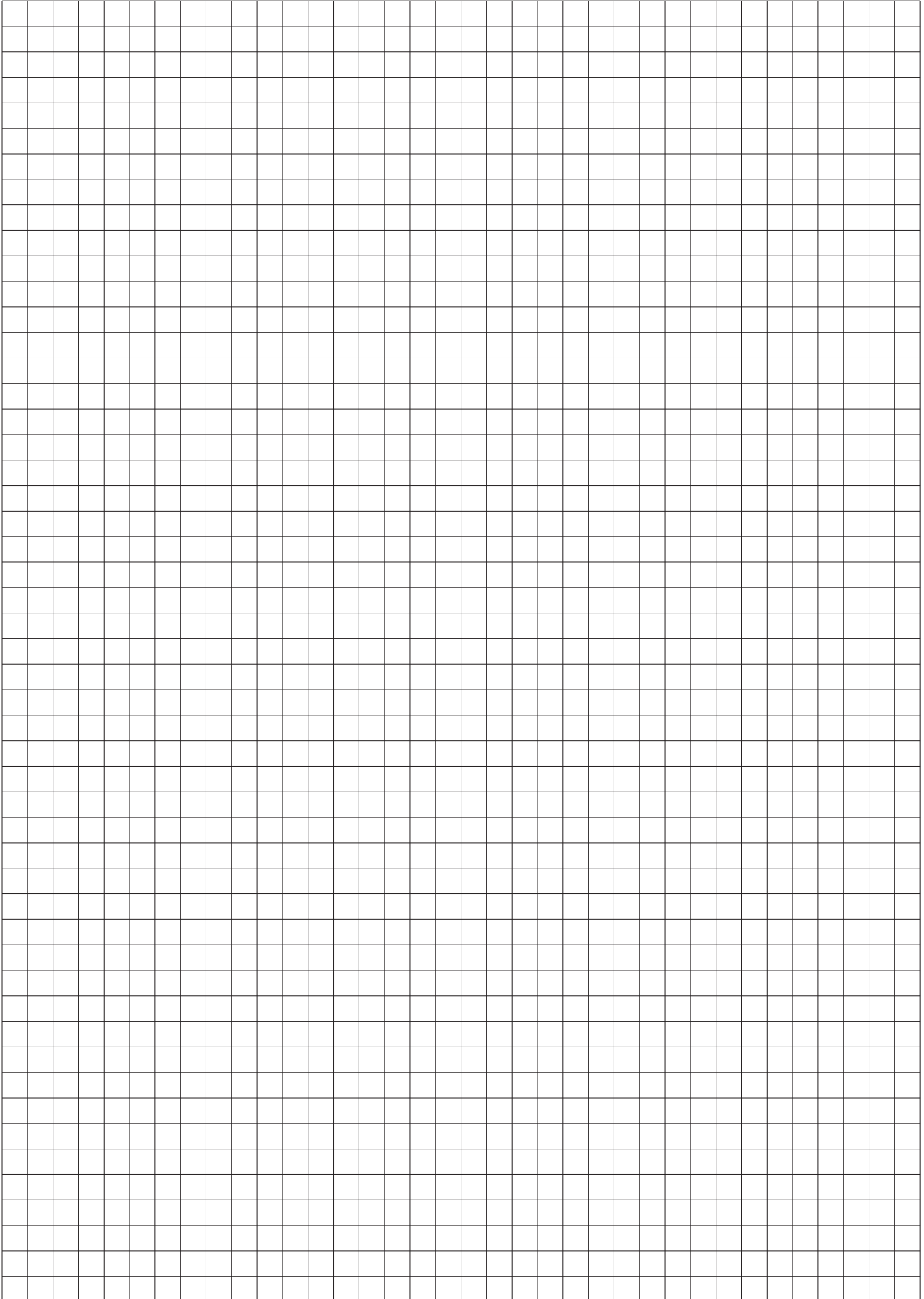

DATA	SCHEDA
Maggio 2016	SP01

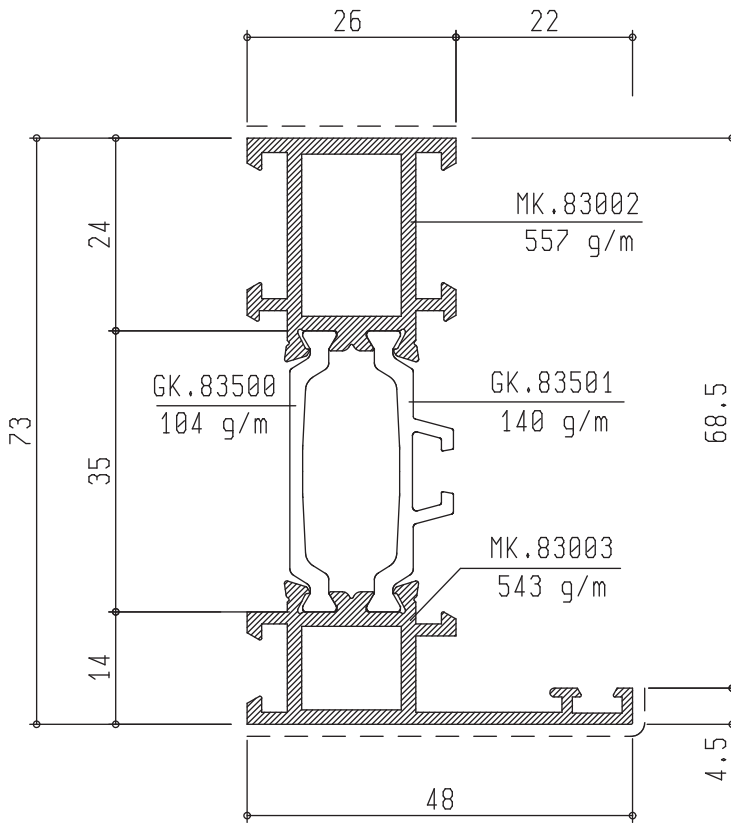

KK.83001

TELAIO FISSO "L" 26/48 mm

Peso: 1344 g/m
Perim. in vista: 79 mm

Jx cm⁴ 31.13
Jy cm⁴ 4.73
Wx cm³ 9.25
Wy cm³ 3.03

Squadretta Interna AK.83701

Squadretta Esterna AK.83707

Squadretta Allineamento AK.83718

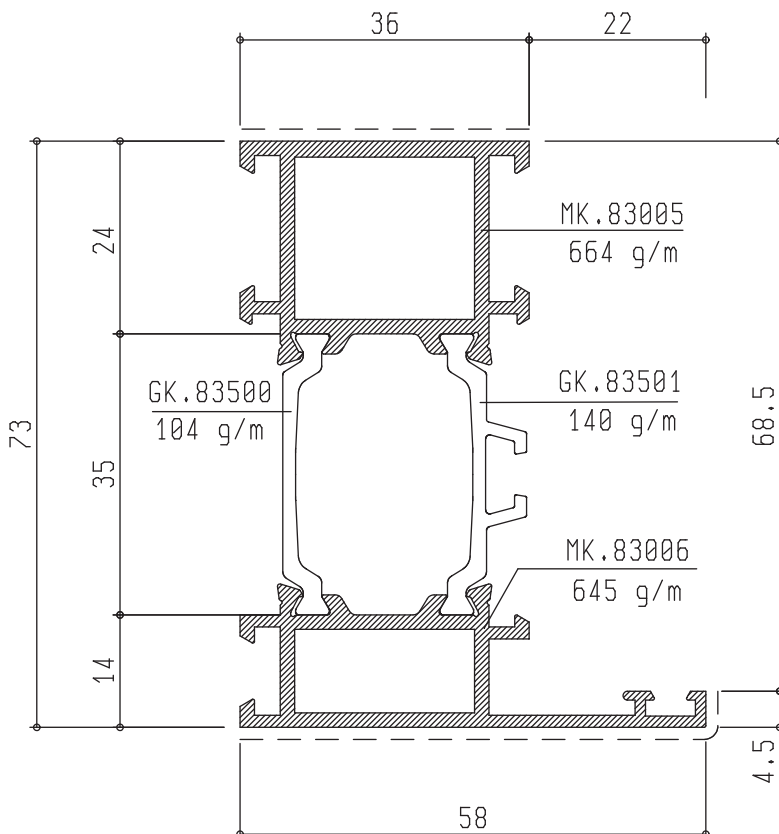

KK.83004

TELAIO FISSO "L" 36/58 mm

Peso: 1553 g/m
Perim. in vista: 99 mm

Jx cm⁴ 37.40
Jy cm⁴ 9.31
Wx cm³ 11.02
Wy cm³ 4.52

Squadretta Interna AK.83702

Squadretta Esterna AK.83708

Squadretta Allineamento AK.83718

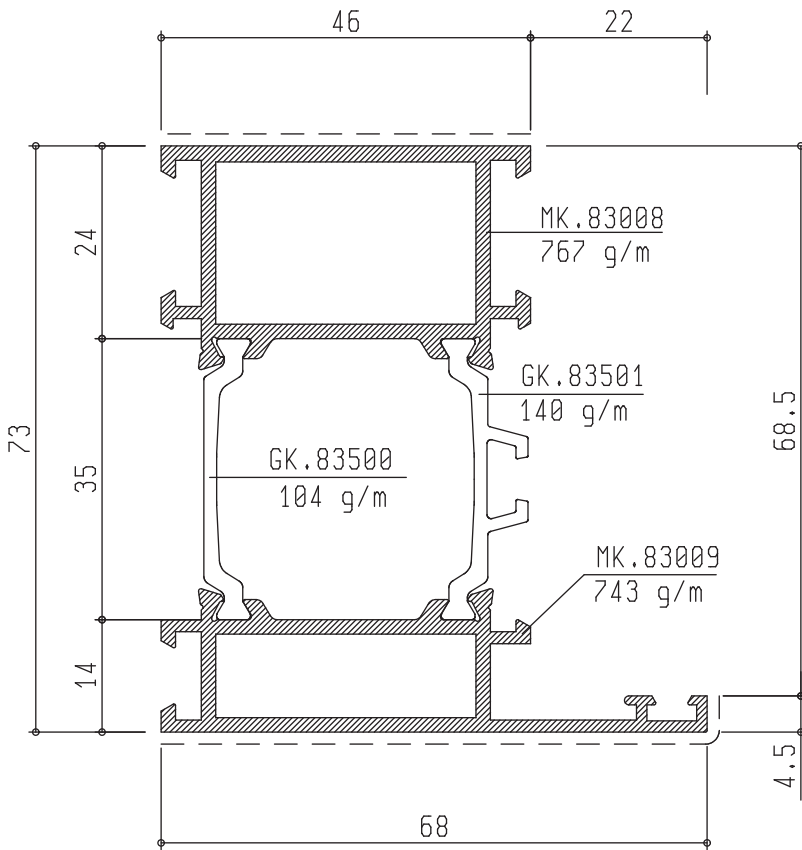

KK.83007

TELAIO FISSO "L" 46/68 mm

Peso: 1754 g/m
Perim.in vista: 119 mm

Jx cm⁴ 43.42
Jy cm⁴ 16.31
Wx cm³ 12.77
Wy cm³ 3.36

Squadretta Interna AK.83703
Squadretta Esterna AK.83709
Squadretta Allineamento AK.83718

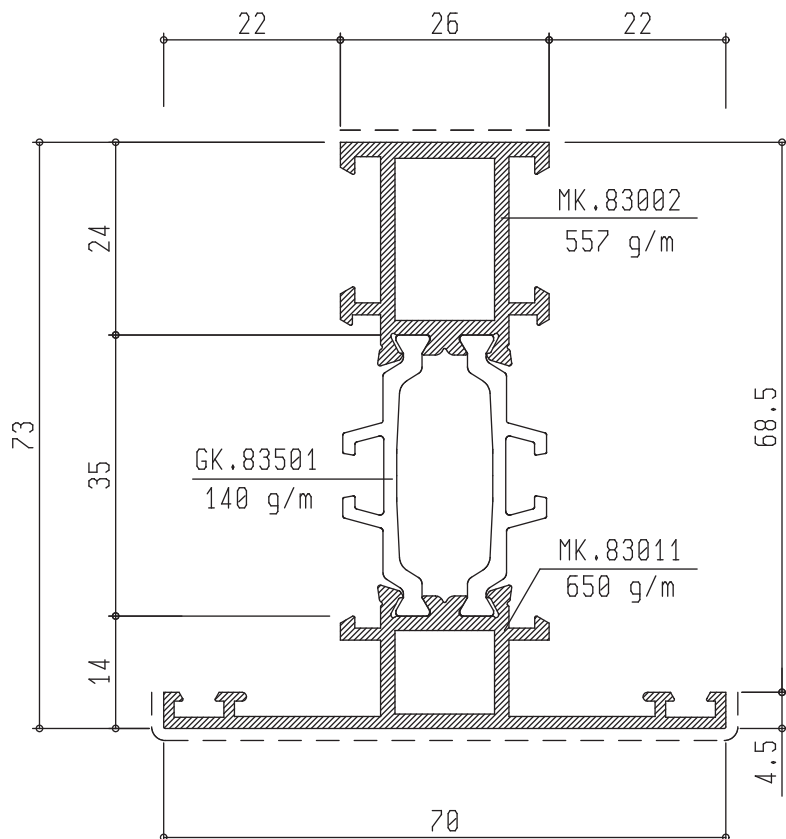

KK.83010

TELAIO FISSO "T" 26/70 mm

Peso: 1487 g/m
Perim.in vista: 105 mm

Jx cm⁴ 35.00
Jy cm⁴ 7.96
Wx cm³ 11.38
Wy cm³ 2.28

Squadretta Interna AK.83701
Squadretta Esterna AK.83707
Squadretta Allineamento AK.83718 2 PZ

FASCIA SU TELAI FISSI

Cavallotto Interno AK.83717
Cavallotto Esterno AK.83718 2 Pz.

FASCIA SU TELAI MOBILI

Cavallotto Interno AK.83717
Cavallotto Esterno AK.83727

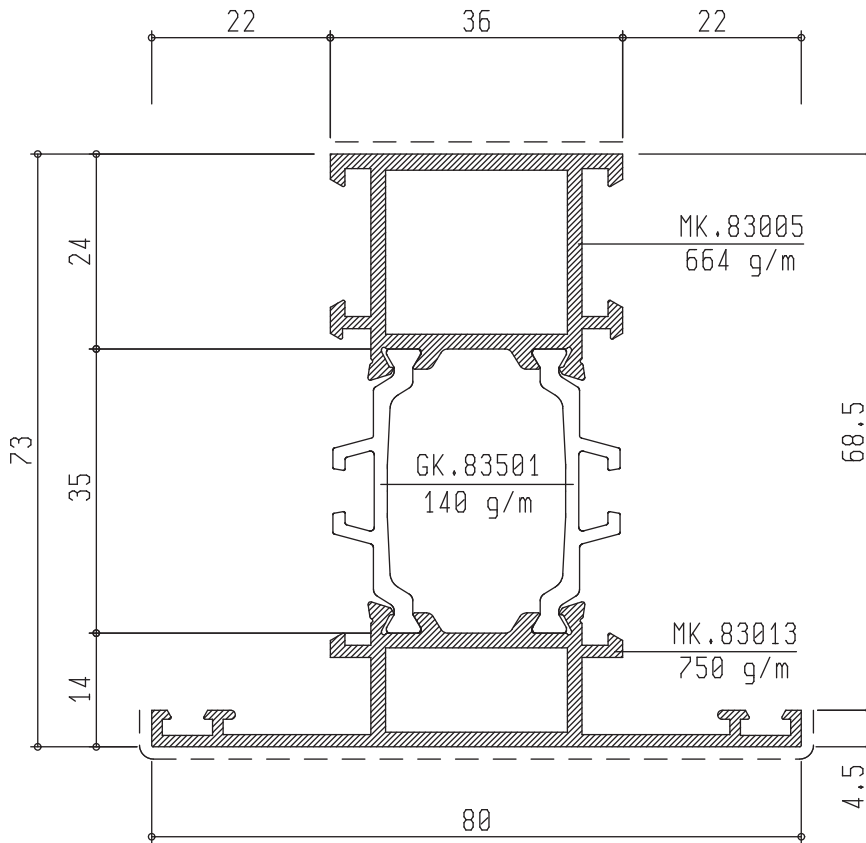

KK.83012

TELAIO FISSO "T" 36/80 mm

Peso: 1694 g/m
Perim. in vista: 125 mm

Jx cm⁴ 41.28
Jy cm⁴ 13.76
Wx cm³ 13.17
Wy cm³ 3.45

Squadretta Interna AK.83702
Squadretta Esterna AK.83708
Squadretta Allineamento AK.83718 2 PZ

FASCIA

Cavallotto Interno AK.83719
Cavallotto Esterno AK.83720
Squadretta Allineamento AK.83718 2 PZ

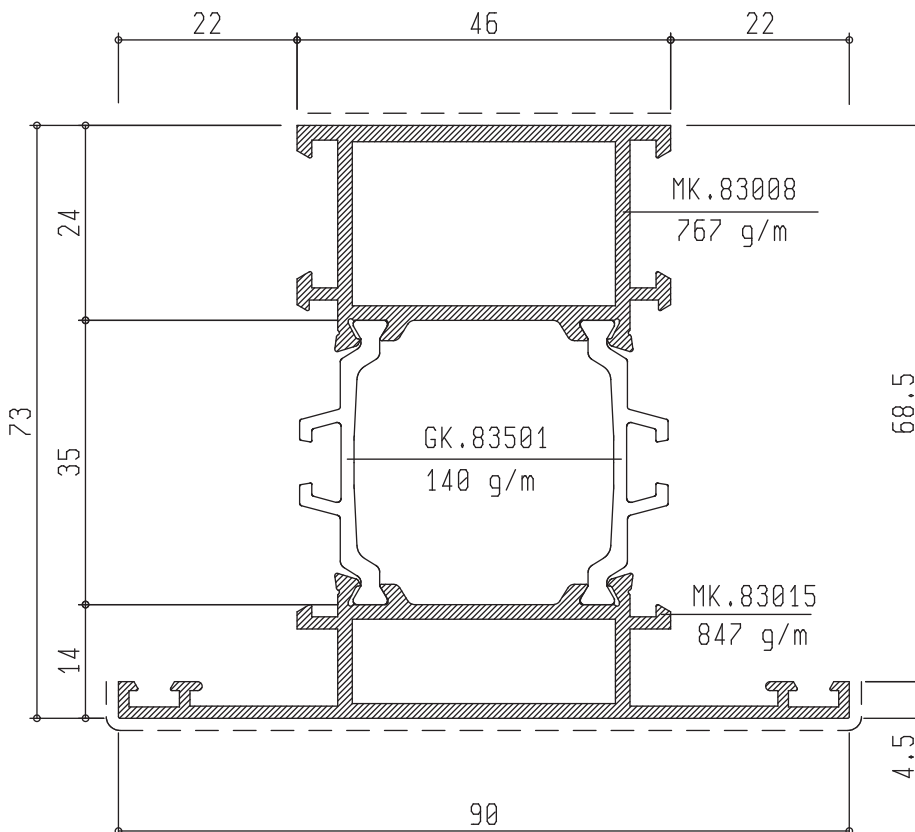

KK.83014

TELAIO FISSO "T" 46/90 mm

Peso: 1894 g/m
Perim. in vista: 145 mm

Jx cm⁴ 47.48
Jy cm⁴ 22.17
Wx cm³ 15.02
Wy cm³ 4.92

Squadretta Interna AK.83703
Squadretta Esterna AK.83709
Squadretta Allineamento AK.83718 2 PZ

FASCIA

Cavallotto Interno AK.83721
Cavallotto Esterno AK.83722
Squadretta Allineamento AK.83718 2 PZ



KK.83016

FASCIA 86/130 mm

Peso: 2694 g/m

Perim. in vista: 225 mm

$J_x \text{ cm}^4$ 72.05

$J_y \text{ cm}^4$ 89.47

$W_x \text{ cm}^3$ 22.06

$W_y \text{ cm}^3$ 13.80

Cavallotto Interno AK.83721 2 PZ

Cavallotto Esterno AK.83722 2 PZ

Squadretta Allineamento AK.83718 2 PZ

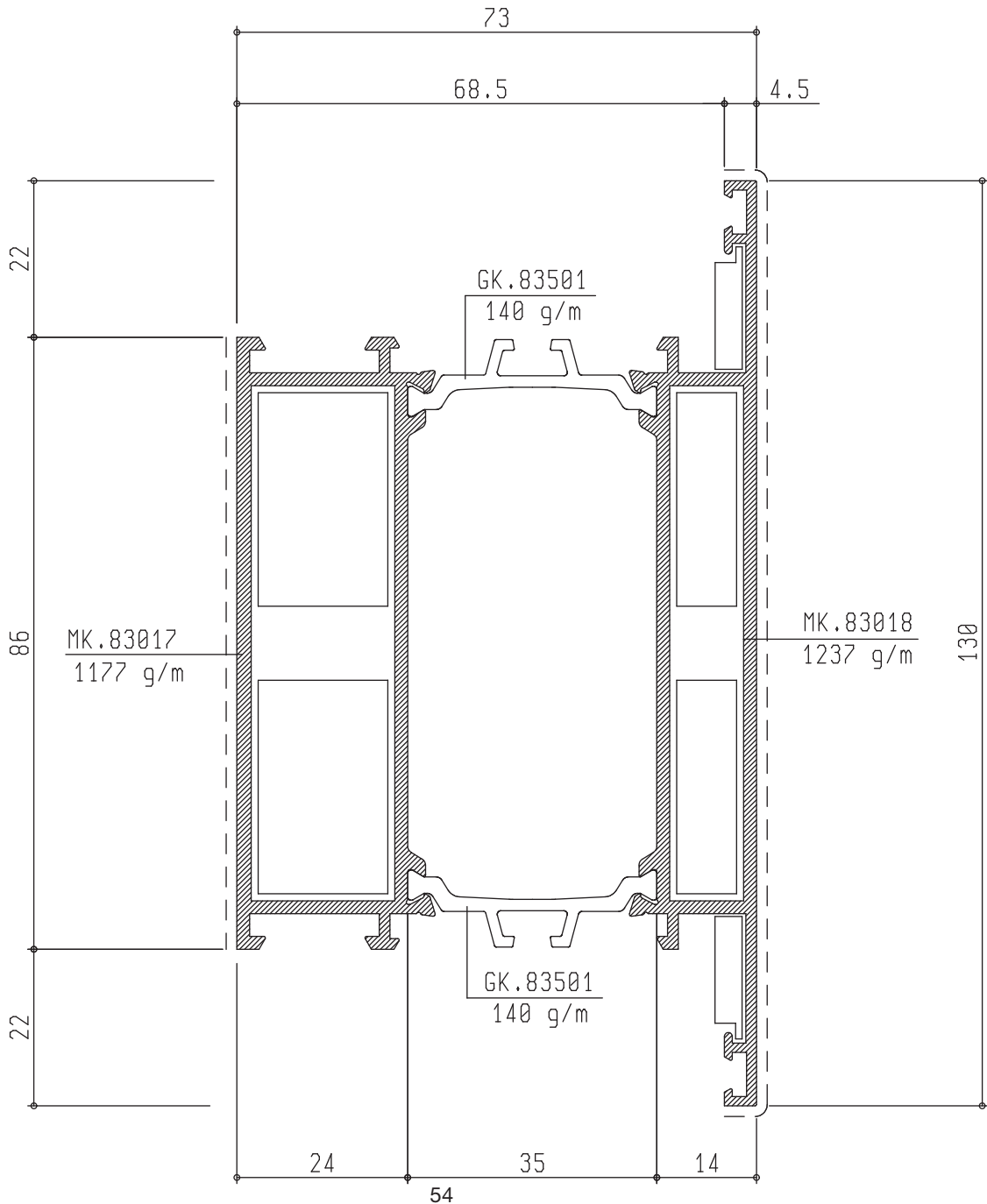



KK.83019

FASCIA 106/150 mm

Peso: 3093 g/m

Perim. in vista: 265 mm

$J_x \text{ cm}^4$ 84.32

$J_y \text{ cm}^4$ 148.61

$W_x \text{ cm}^3$ 39.87

$W_y \text{ cm}^3$ 14.03

Cavallotto AK.83721 2 PZ
Interno

Cavallotto AK.83722 2 PZ
Esterno

Squadretta AK.83718 2 PZ
Allineamento

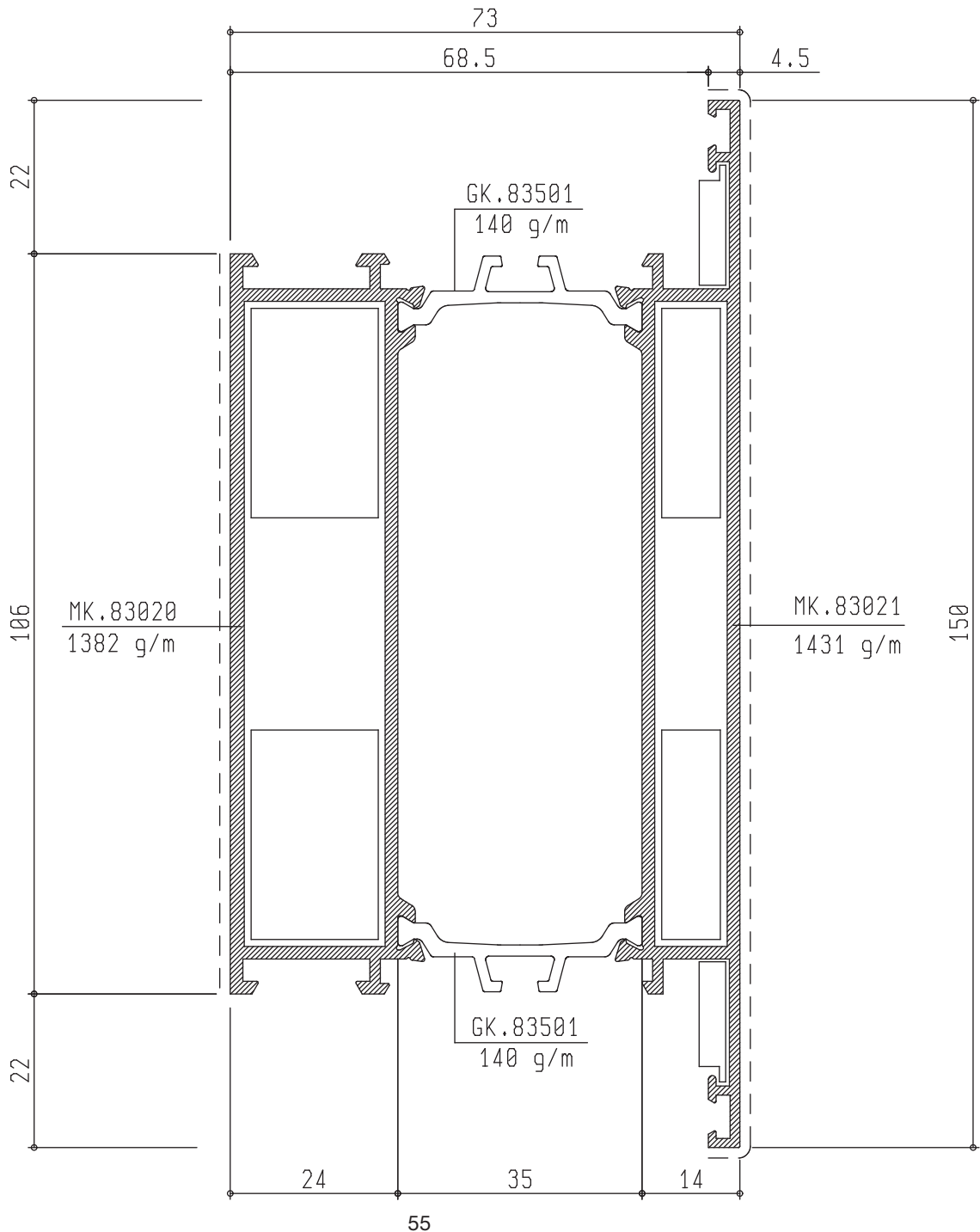



KK.83022

ZOCCOLO DA 150 mm

Peso: 3146 g/m
Perim. in vista: 287 mm

$J_x \text{ cm}^4$ 90.33
 $J_y \text{ cm}^4$ 164.29
 $W_x \text{ cm}^3$ 26.15
 $W_y \text{ cm}^3$ 22.55

Cavallotto AK.83721 2 PZ
Interno
Cavallotto AK.83722 2 PZ
Esterno
Squadretta AK.83718 2 PZ
Allineamento

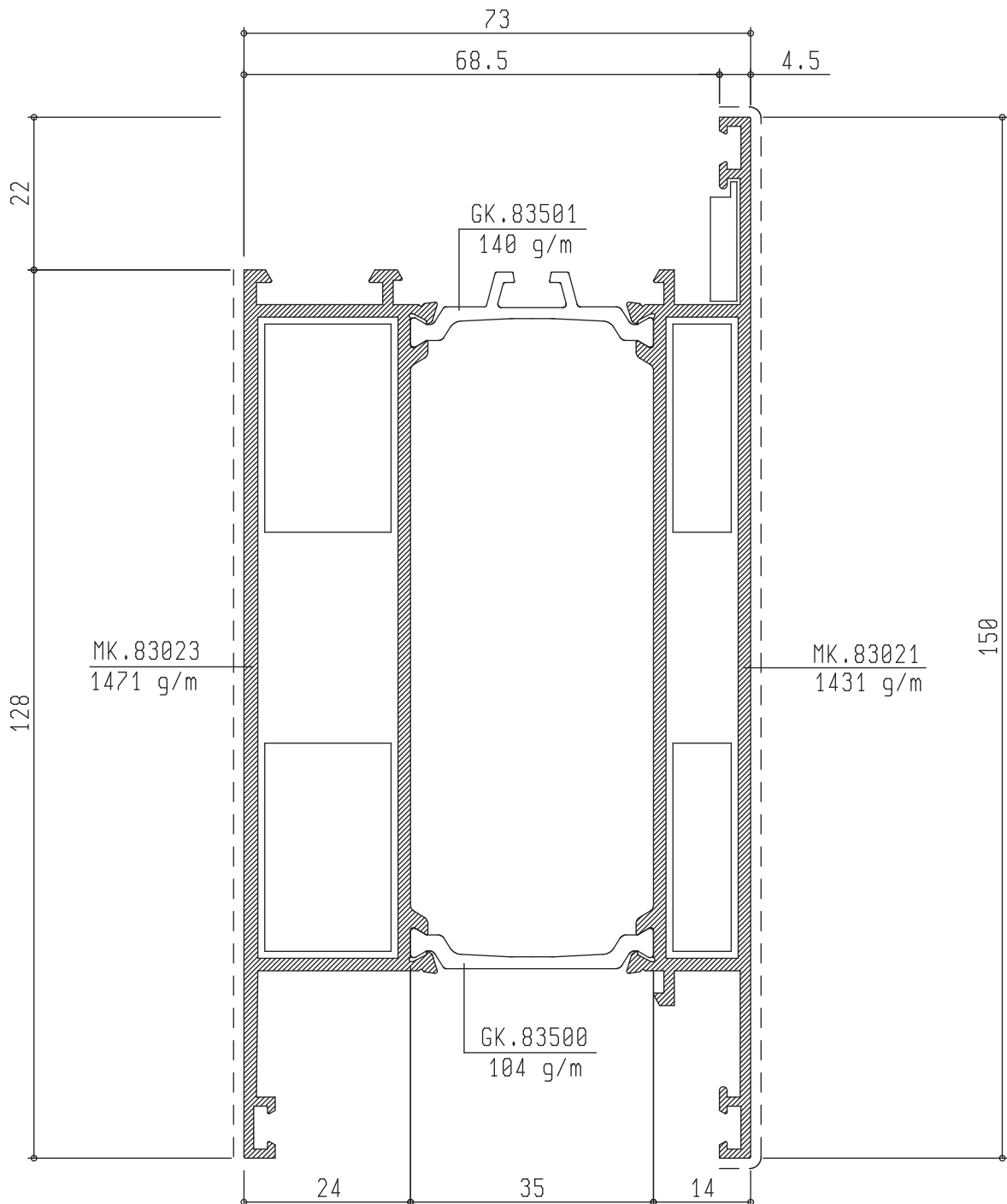

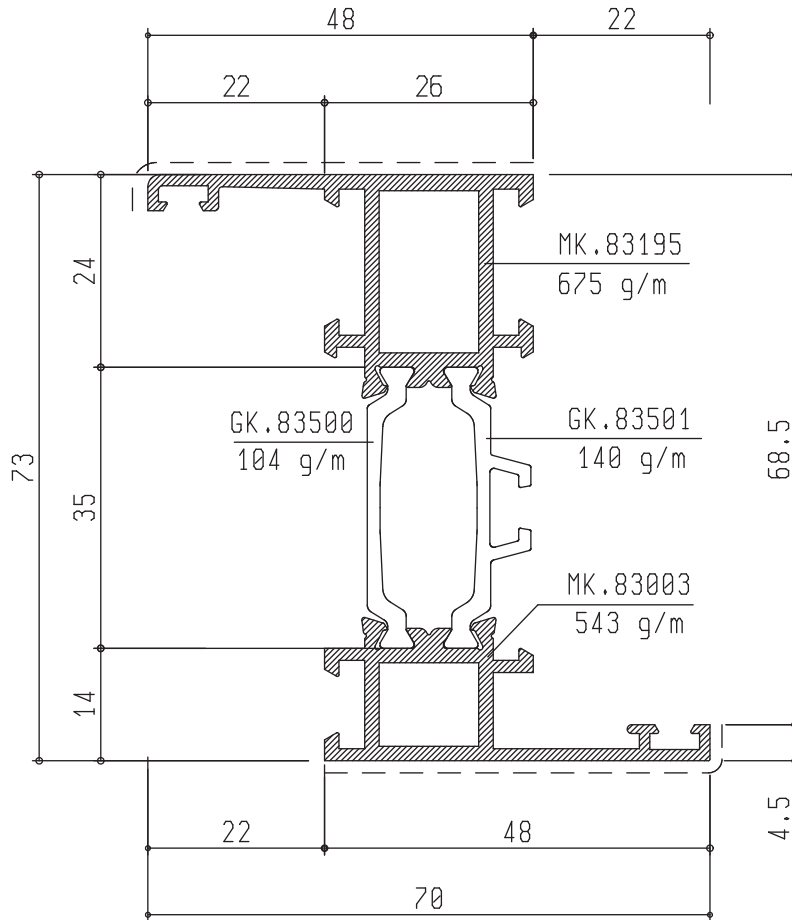

KK.83194

TELAIO FISSO "Z" 48/48 mm
CON ALETTA DI BATTUTA
COMPLANARE DA 22 mm

Peso: 1462 g/m
Perim. in vista: 105 mm

Jx cm⁴ 36.84
Jy cm⁴ 7.92
Wx cm³ 9.87
Wy cm³ 2.26

Squadretta Interna AK.83701

Squadretta Esterna AK.83707

Squadretta Allineamento AK.83718

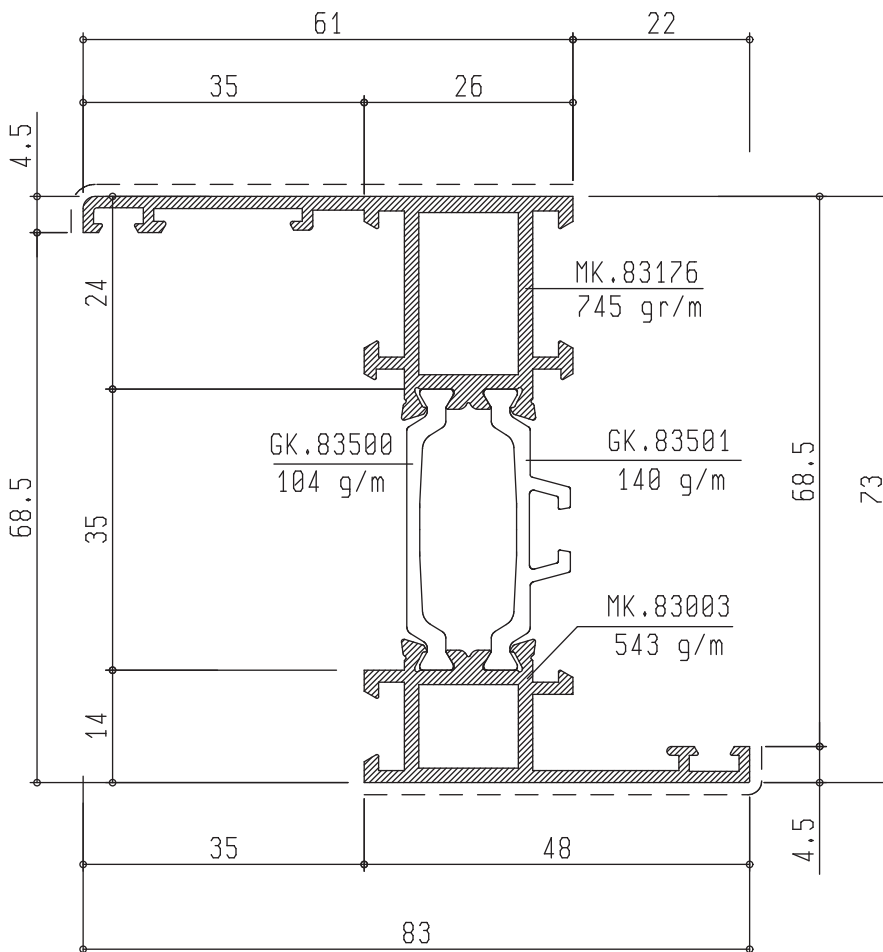

KK.83177

TELAIO FISSO "Z" 61/48 mm
CON ALETTA DI BATTUTA
COMPLANARE DA 35 mm

Peso: 1532 g/m
Perim. in vista: 118 mm

Jx cm⁴ 39.70
Jy cm⁴ 11.33
Wx cm³ 10.13
Wy cm³ 2.70

Squadretta Interna AK.83701

Squadretta Esterna AK.83707

Squadretta Allineamento Interna AK.94139/AK.90029

Squadretta Allineamento Esterna AK.83718

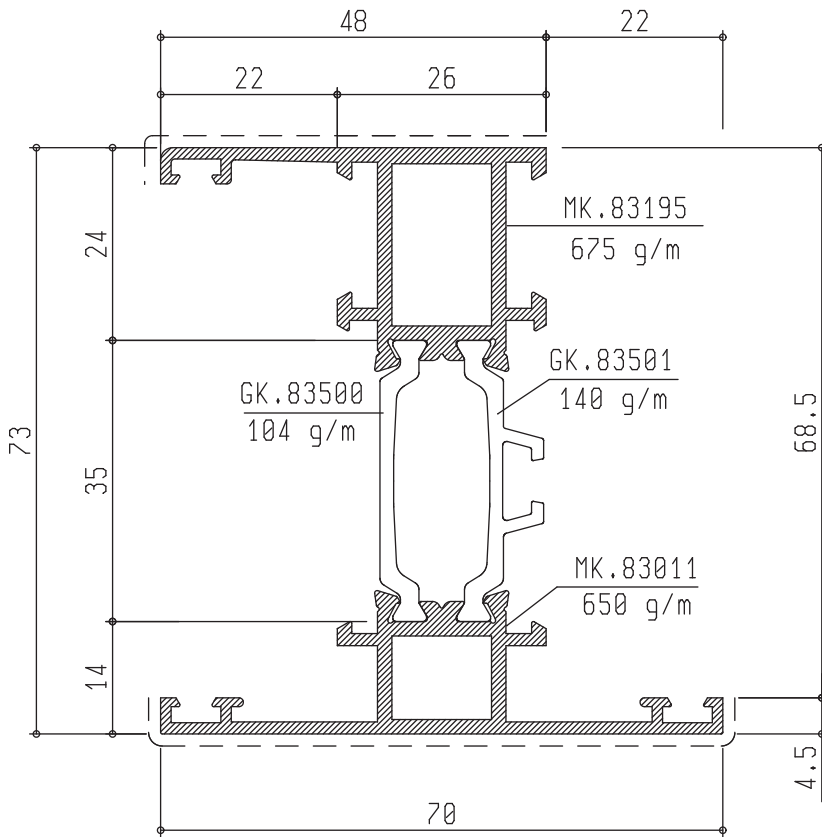

KK.83261

TELAIO FISSO "H" 48/70 mm

Peso: 1569 g/m

Perim.in vista: 132 mm

Jx cm⁴ 41.70

Jy cm⁴ 10.70

Wx cm³ 12.20

Wy cm³ 3.30

Squadretta AK.83701
Interna

Squadretta AK.83707
Esterna

Squadretta AK.83718
Allineamento

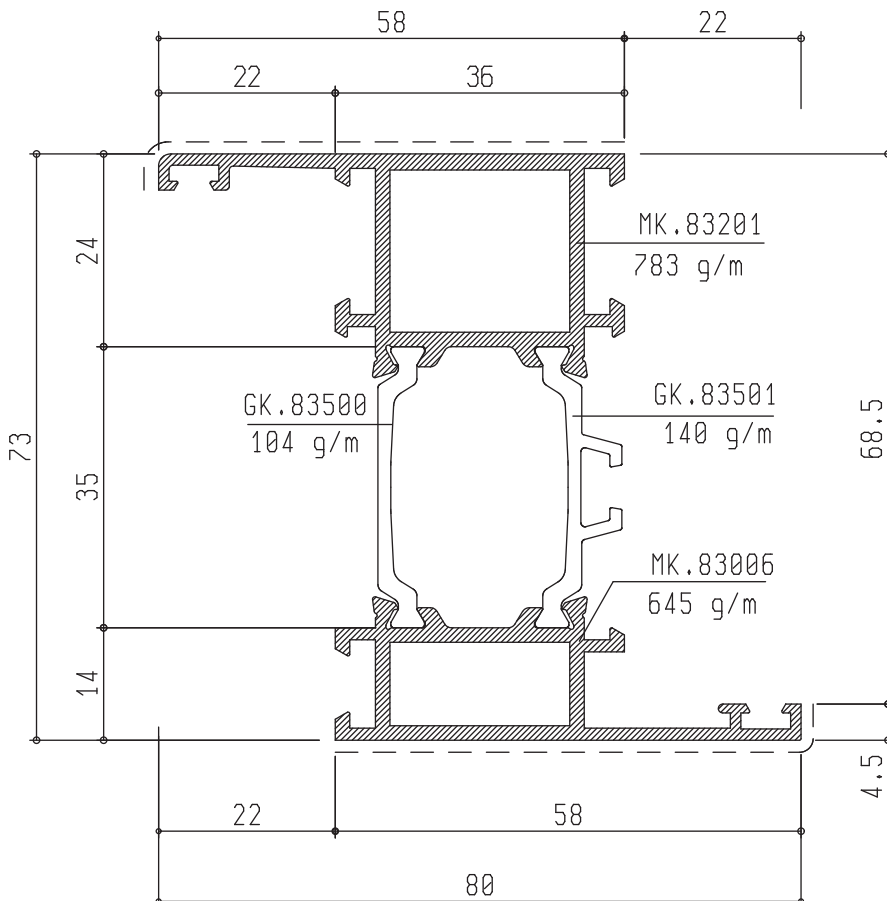

KK.83200

TELAIO FISSO "Z" 58/58 mm
CON ALETTA DI BATTUTA
COMPLANARE DA 22 mm

Peso: 1672 g/m

Perim. in vista: 126 mm

Jx cm⁴ 43.07

Jy cm⁴ 13.75

Wx cm³ 11.65

Wy cm³ 3.72

Squadretta AK.83702
Interna

Squadretta AK.83708
Esterna

Squadretta AK.83718
Allineamento

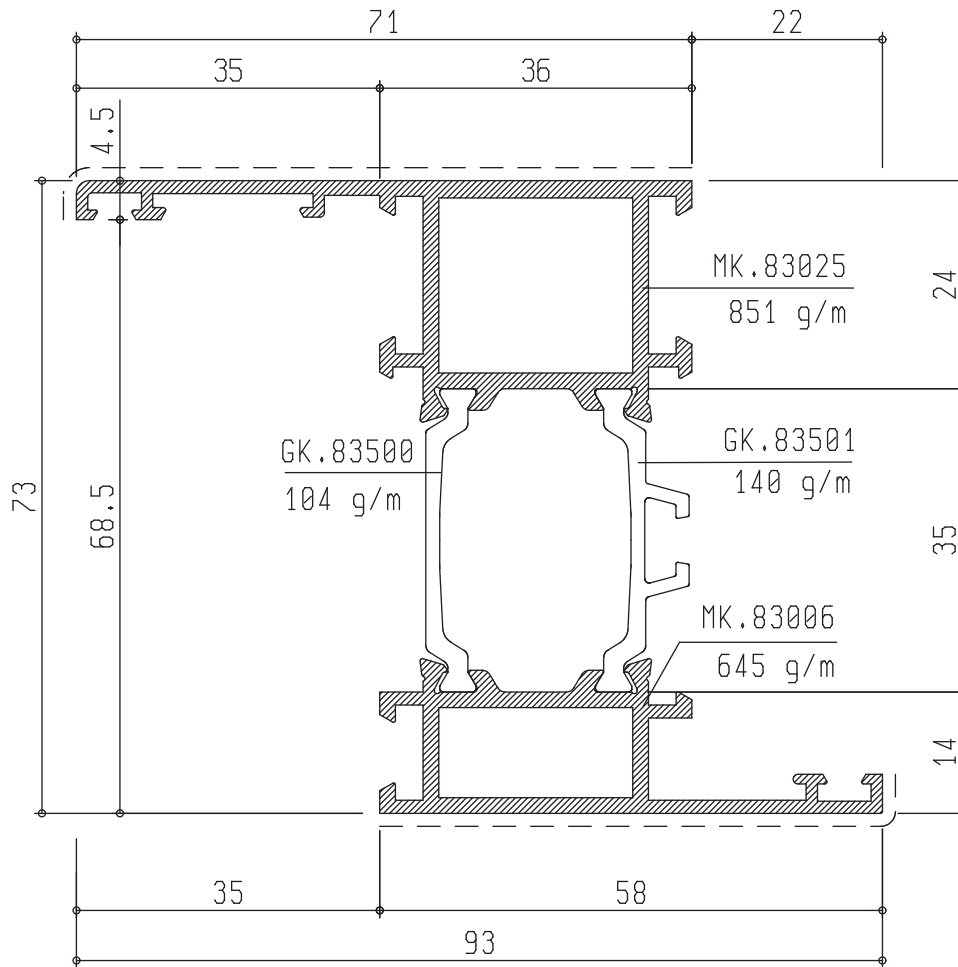

KK.83024

TELAIO FISSO "Z"

71/58 mm
CON ALETTA DI BATTUTA
COMPLANARE DA 35 mm

Peso: 1740 g/m
Perim. in vista: 138 mm

Jx cm⁴ 46.00
Jy cm⁴ 19.28
Wx cm³ 11.74
Wy cm³ 3.80

Squadretta Interna AK.83702
Squadretta Esterna AK.83708
Squadretta Allineamento Interna AK.94139/AK.90029
Squadretta Allineamento Esterna AK.83718

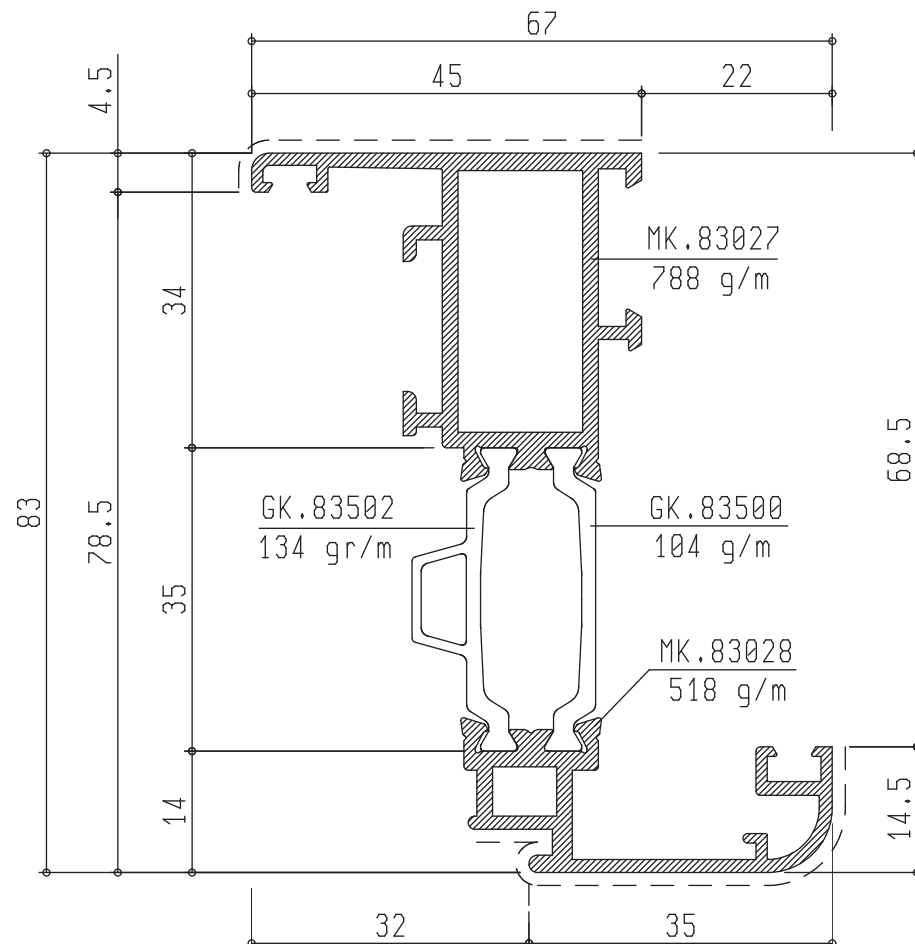

KK.83026

TELAIO MOBILE "Z"

45/35 mm

Peso: 1544 g/m
Perim. in vista: 113 mm

Jx cm⁴ 46.50
Jy cm⁴ 9.75
Wx cm³ 10.66
Wy cm³ 2.86

Squadretta Interna AK.83704
Squadretta Esterna AK.83710
Squadretta Allineamento AK.83725

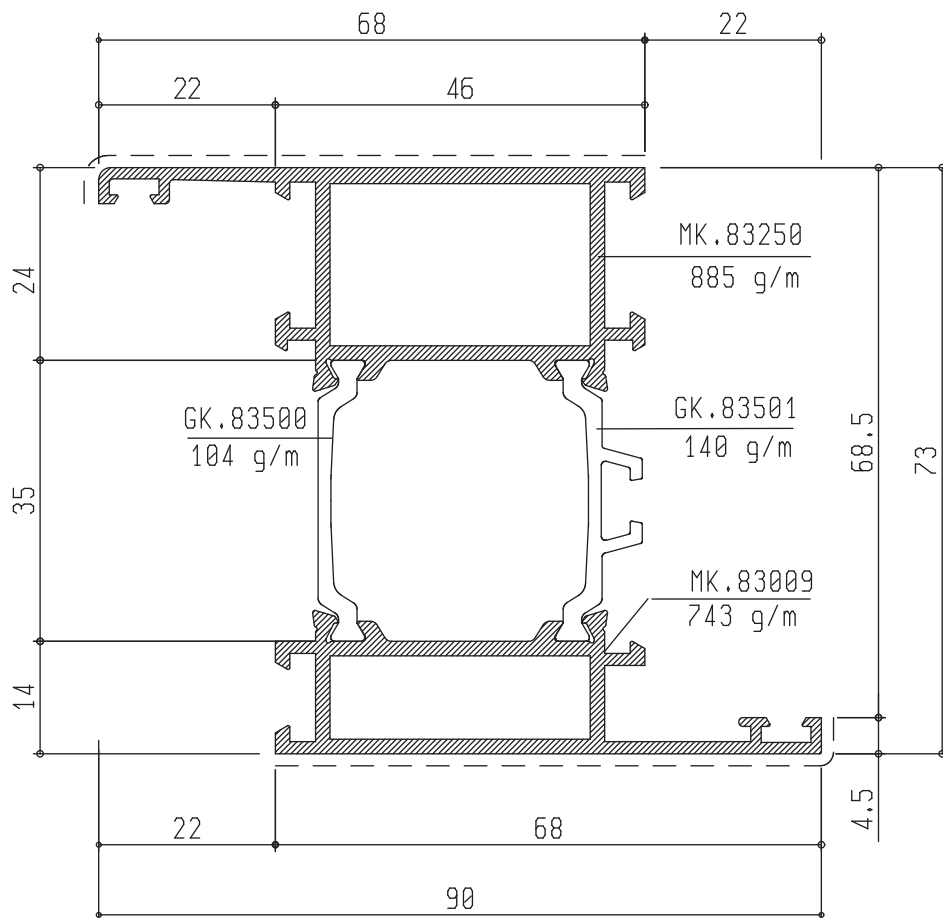

KK.83249

TELAIO FISSO "Z" 68/68 mm
CON ALETTA DI BATTUTA
COMPLANARE DA 22 mm

Peso: 1672 g/m
Perim. in vista: 126 mm

Jx cm⁴ 49.30
Jy cm⁴ 22.30
Wx cm³ 13.50
Wy cm³ 5.00

Squadretta Interna AK.83703
Squadretta Esterna AK.83709
Squadretta Allineamento AK.83718

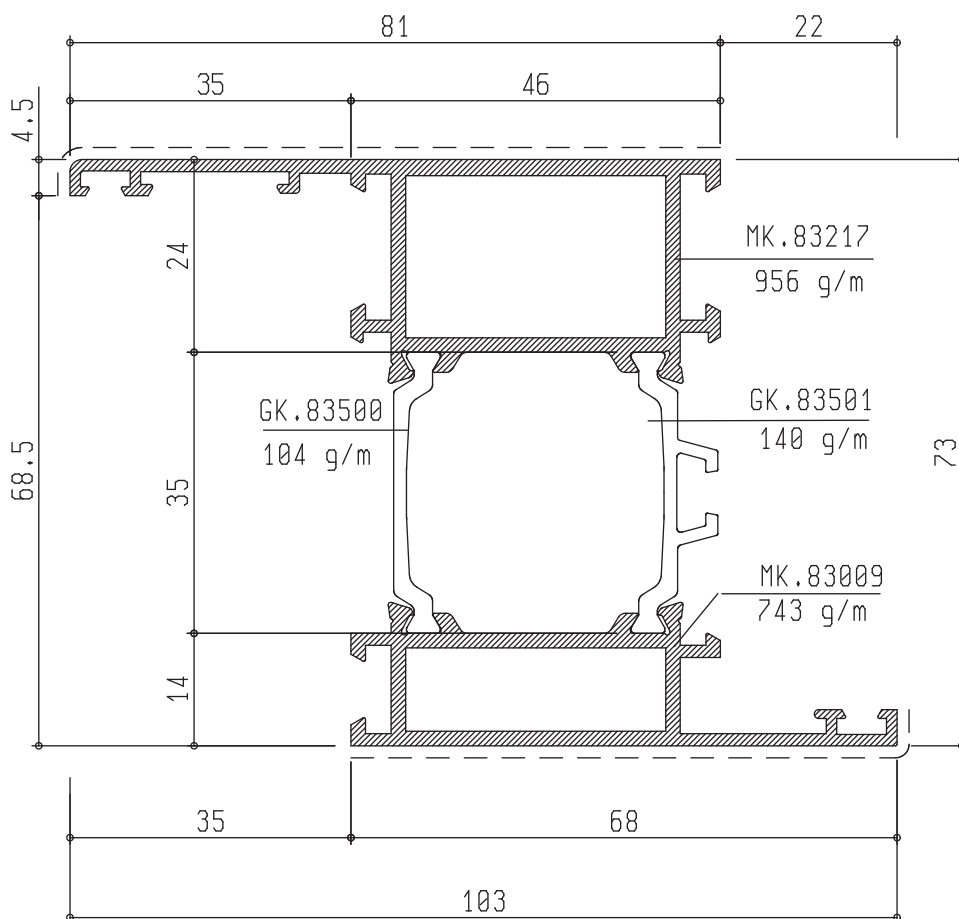

KK.83216

TELAIO FISSO "Z" 81/68 mm
CON ALETTA DI BATTUTA
COMPLANARE DA 35 mm

Peso: 1943 g/m
Perim. in vista: 158 mm

Jx cm⁴ 52.17
Jy cm⁴ 29.00
Wx cm³ 13.70
Wy cm³ 5.30

Squadretta Interna AK.83703
Squadretta Esterna AK.83709
Squadretta Allineamento Interna AK.94139/AK.90029
Squadretta Allineamento Esterna AK.83718



Sistemi

TGP TH73

DATA	SCHEDA
Maggio 2016	SP11

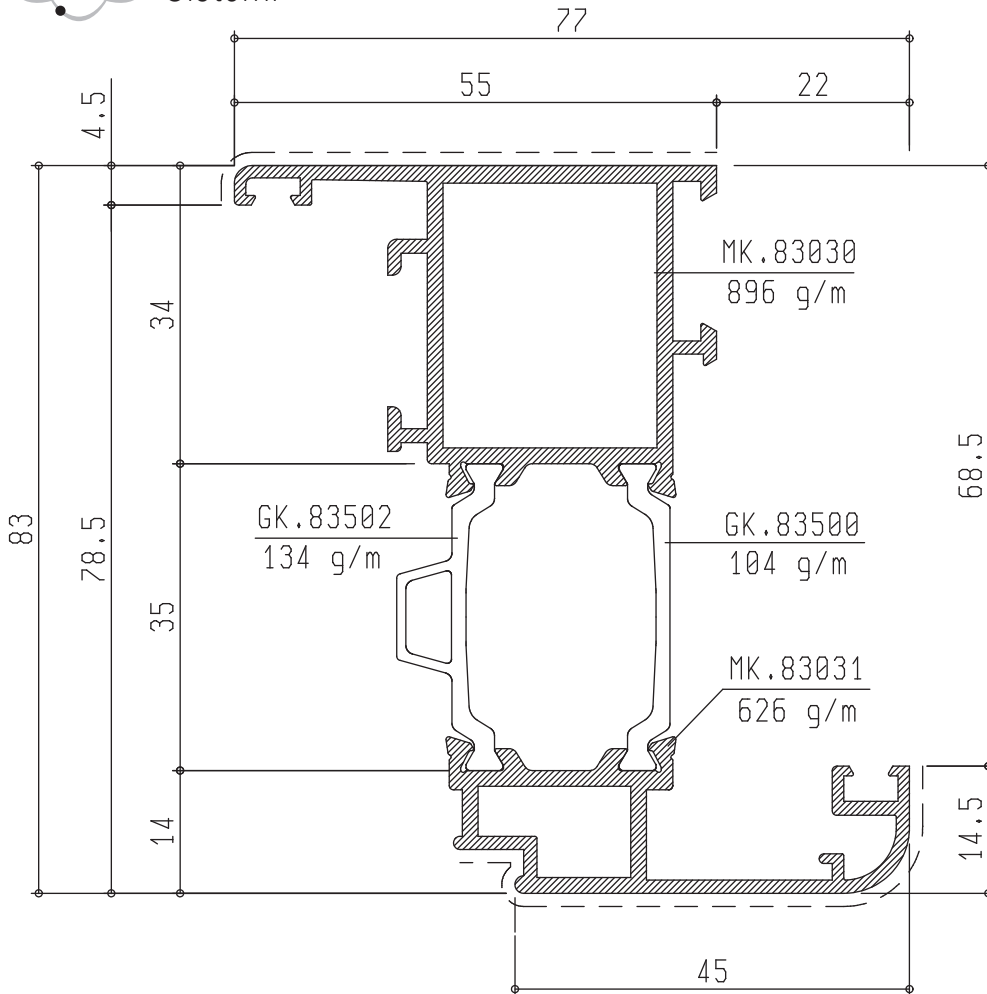

KK.83029

TELAIO MOBILE "Z"
55/45 mm

Peso: 1760 g/m
Perim. in vista: 132 mm

Jx cm⁴ 54.93
 Jy cm⁴ 16.30
 Wx cm³ 12.89
 Wy cm³ 4.18

Squadretta Interna AK.83705
 Squadretta Esterna AK.83711
 Squadretta Allineamento AK.83725

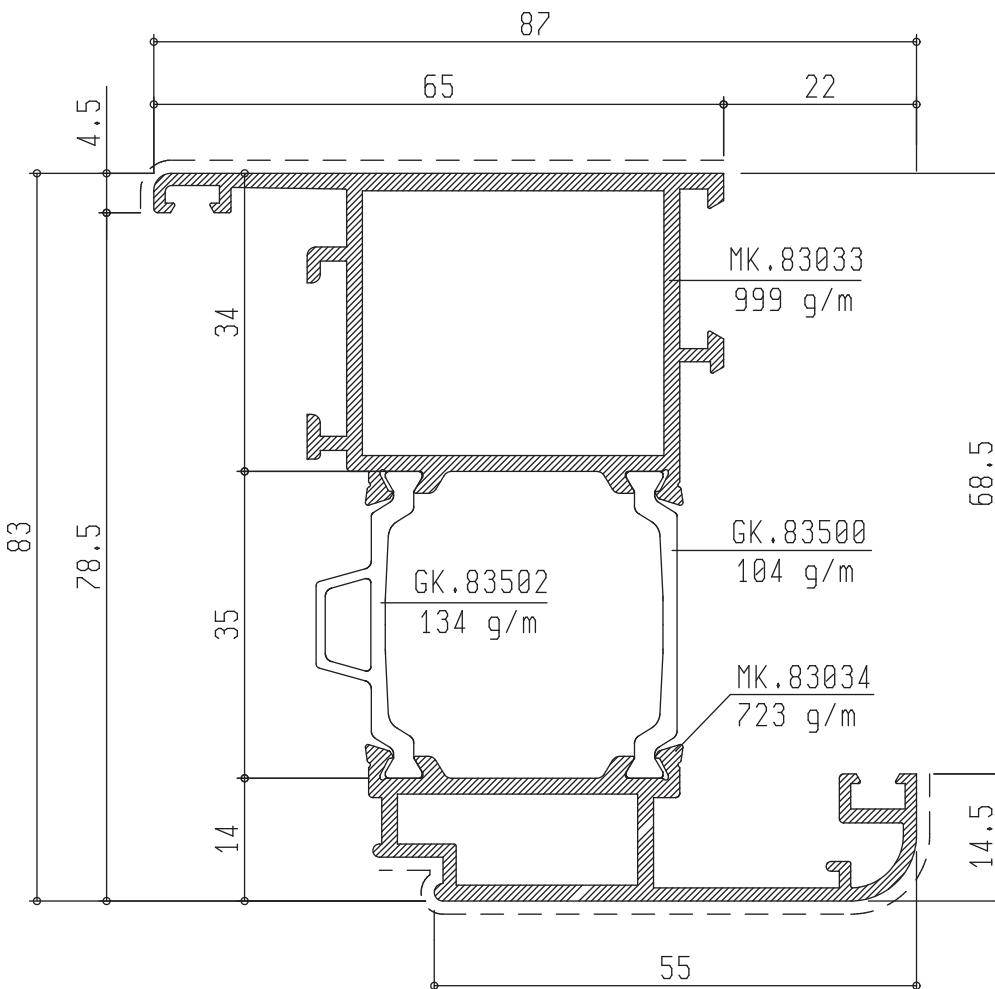

KK.83032

TELAIO MOBILE "Z"
65/55 mm

Peso: 1960 g/m
Perim. in vista: 151 mm

Jx cm⁴ 62.81
 Jy cm⁴ 25.67
 Wx cm³ 14.94
 Wy cm³ 5.83

Squadretta Interna AK.83706
 Squadretta Esterna AK.83712
 Squadretta Allineamento AK.83725

DATA	SCHEDA
Maggio 2016	SP12

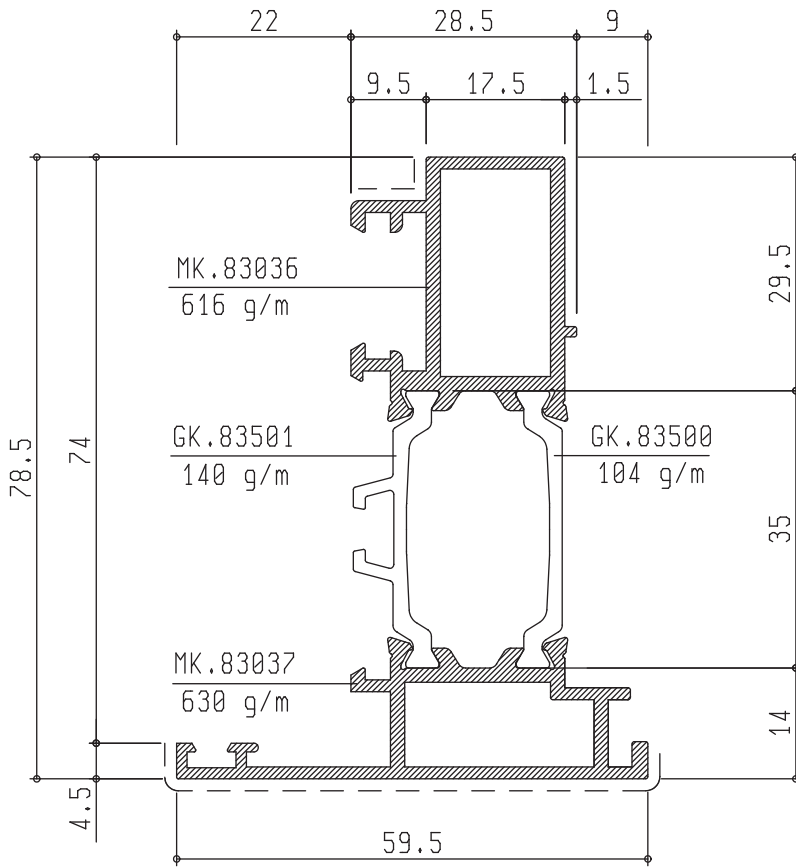

KK.83035

BATTUTA CENTRALE RIPORTATA
SOLUZIONE COMPLANARE

Peso: 1490 g/m
Perim. in vista: 84 mm

Jx cm⁴ 30.37
Jy cm⁴ 7.50
Wx cm³ 11.12
Wy cm³ 2.12

TAPPO A SCELTA

- RIGIDO AK.83814R
- MORBIDO AK.83814M

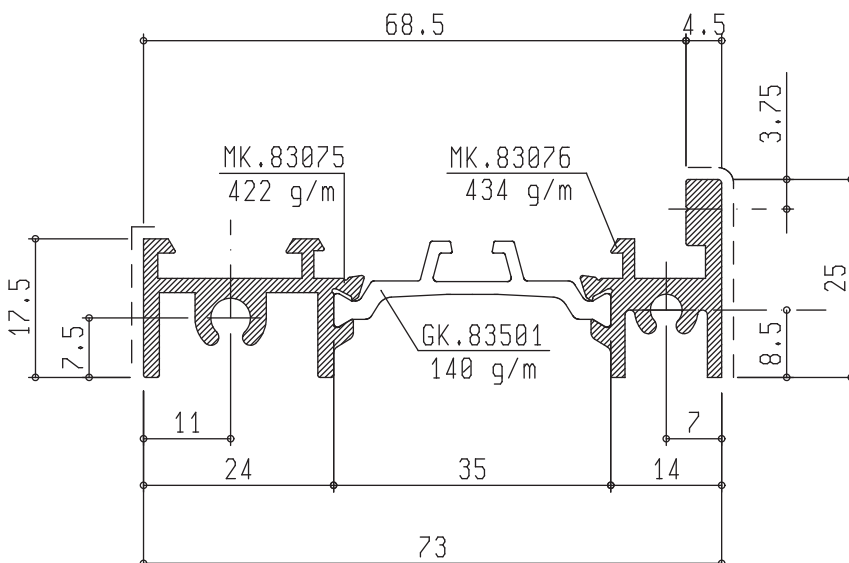

KK.83074

SOGLIA RIDOTTA
CON GIUNTO APERTO

Peso: 996 g/m
Perim. in vista: 50 mm

Jx cm⁴ 0.90
Jy cm⁴ 24.35
Wx cm³ 0.84
Wy cm³ 6.08

DATA	SCHEDA
Maggio 2016	SP13

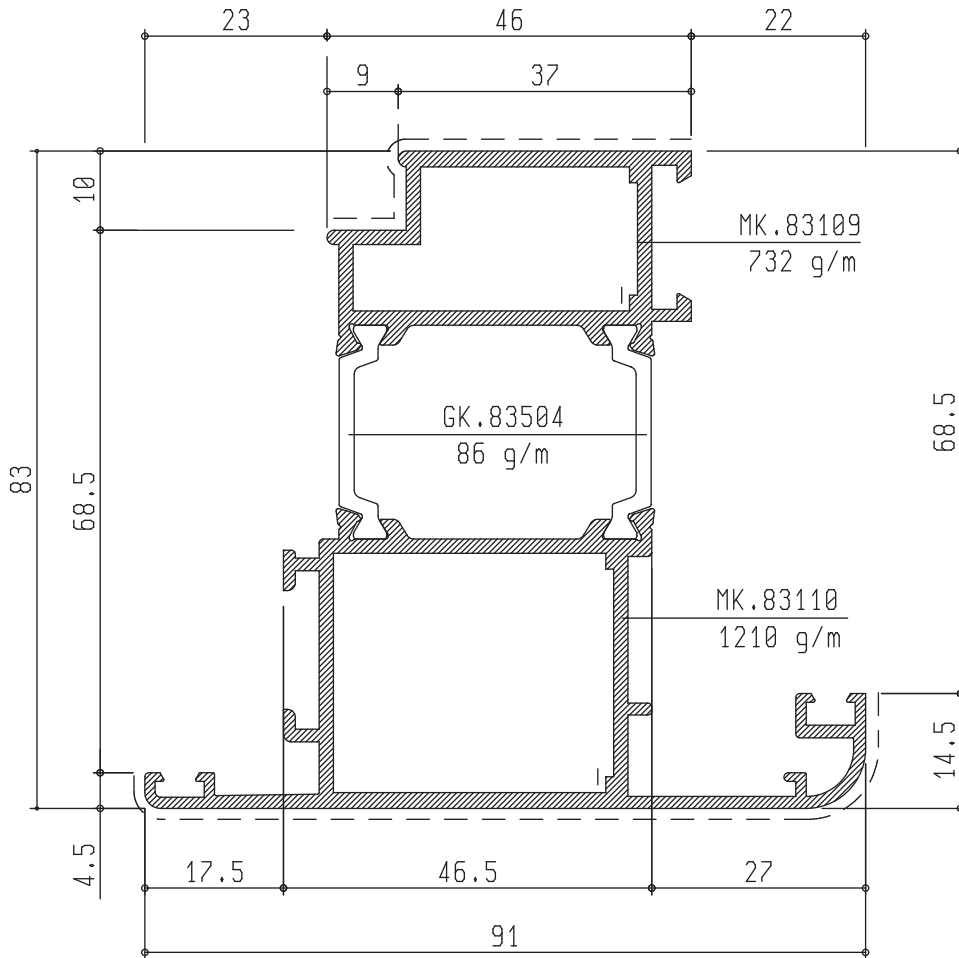

KK.83108

ANTA PER SPORGERE

Peso: 2114 g/m
Perim. in vista: 165 mm

Jx cm⁴ 63.58
Jy cm⁴ 31.25
Wx cm³ 17.88
Wy cm³ 6.80

Squadretta Interna AK.83729

Squadretta Esterna AK.83706

Squadretta Allineamento AK.83725

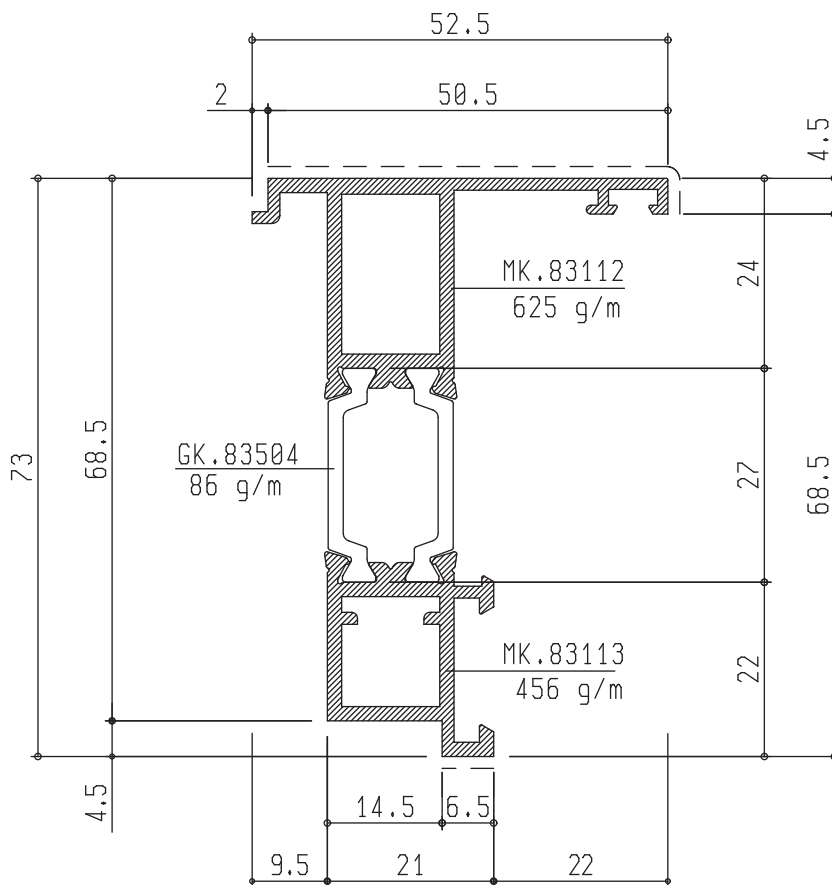

KK.83111

INVERSIONE BATTUTA
PER SPORGERE

Peso: 1253 g/m
Perim. in vista: 61 mm

Jx cm⁴ 26.50
Jy cm⁴ 4.49
Wx cm³ 6.26
Wy cm³ 2.18

Squadretta Interna AK.83701

Squadretta Esterna AK.83707

DATA	SCHEDA
Maggio 2016	SP14

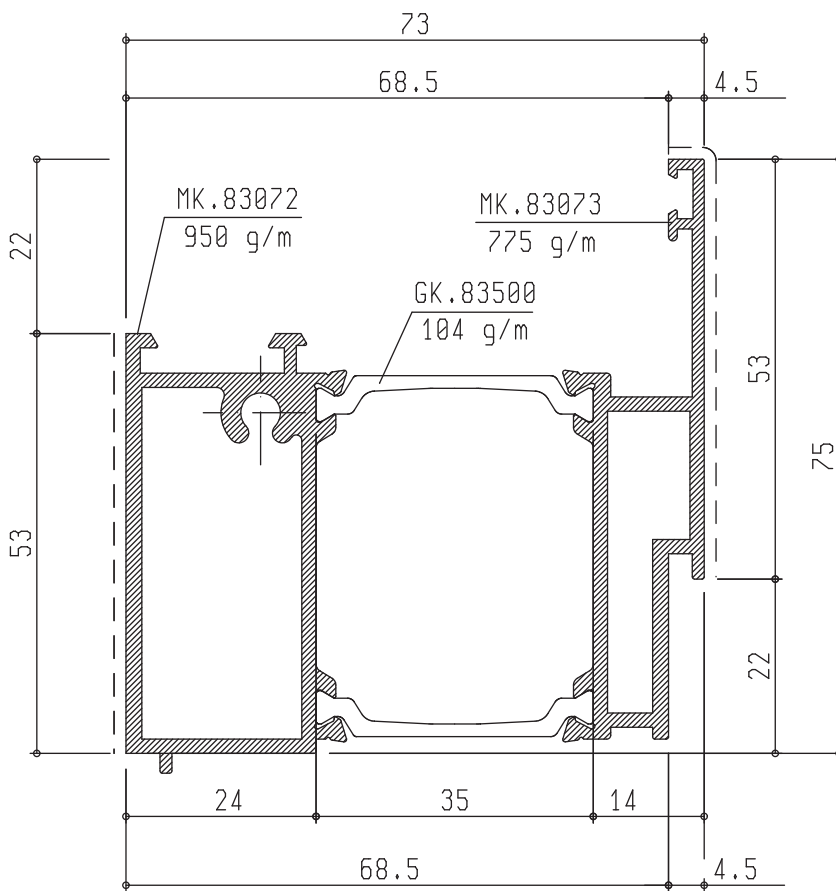

KK.83071

ZOCCOLO RIPORTATO

Peso: 1933 g/m
Perim. in vista: 111 mm

J_x cm⁴ 23.21
 J_y cm⁴ 47.88
 ψ_x cm³ 7.18
 ψ_y cm³ 12.94

DATA	SCHEDA
Maggio 2016	SP15

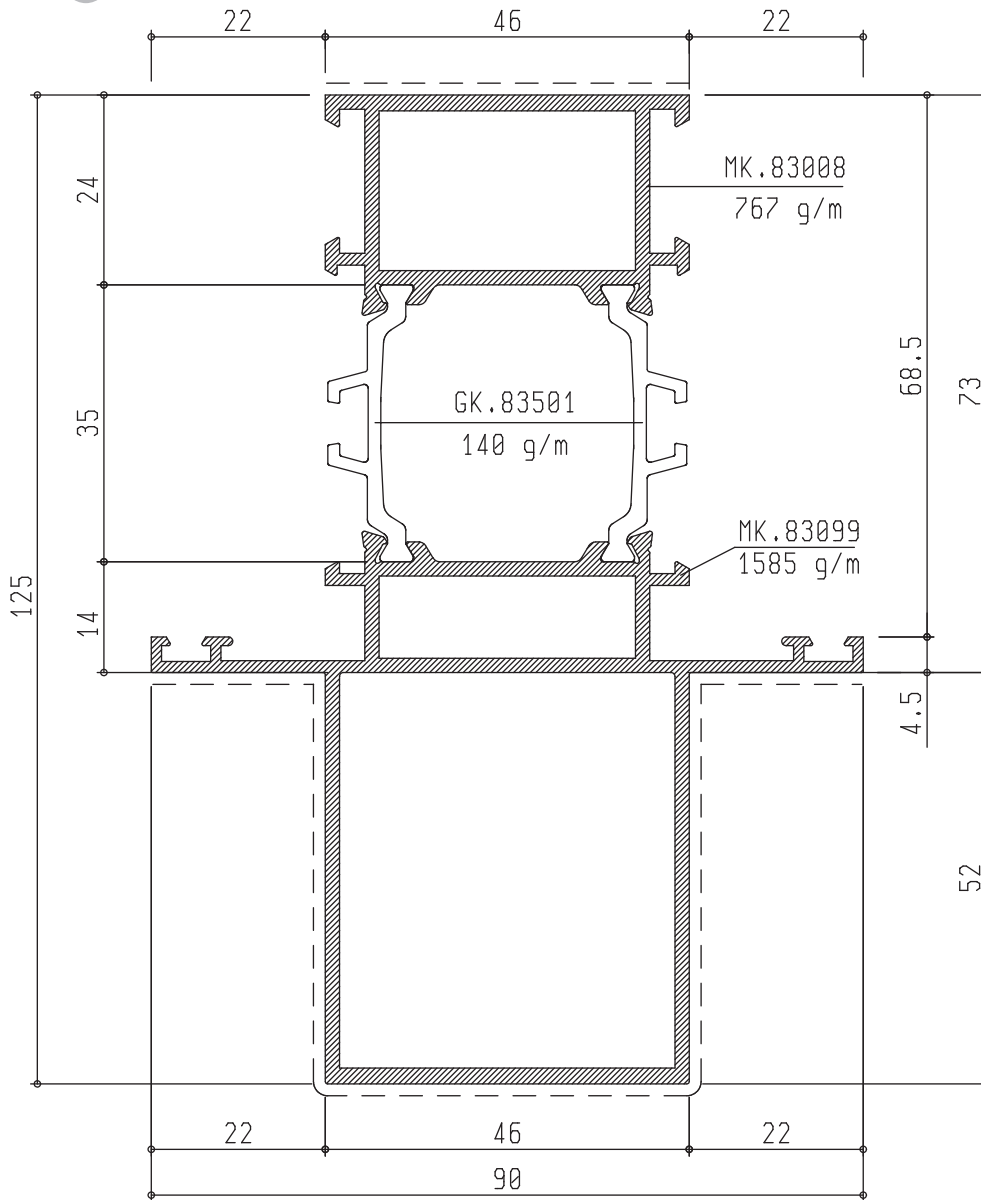

KK.83098

MONTANTE 46/125 mm
RINFORZATO

Peso: 2632 g/m
Perim. in vista: 136 mm

Jx cm⁴ 135.83
Jy cm⁴ 32.60
Wx cm³ 21.45
Wy cm³ 7.24

Squadretta AK.83718
Allineamento
Esterna

Esempio applicazione

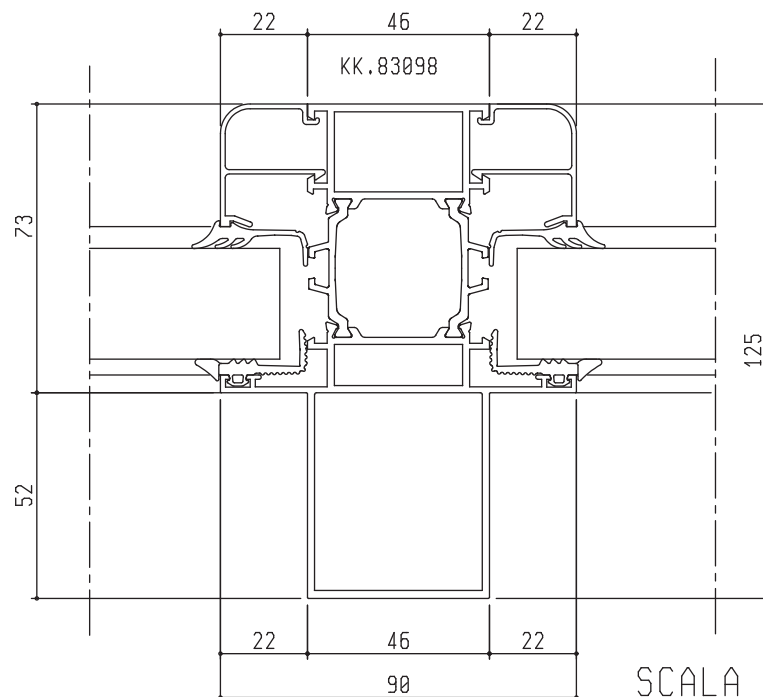

SCALA 1:2

DATA	SCHEDA
Maggio 2016	SP16

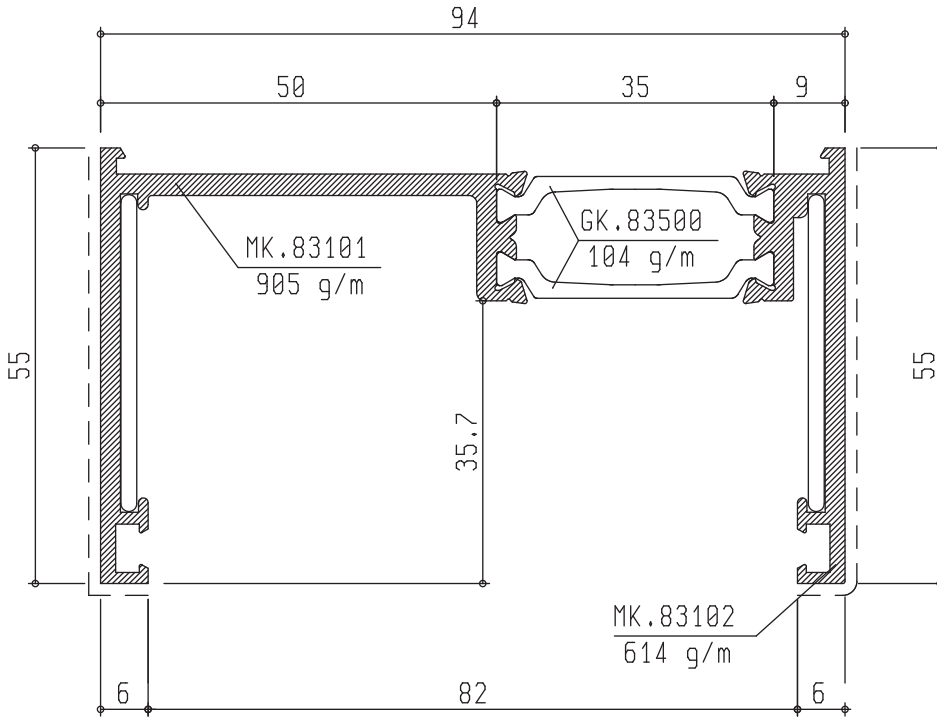

KK.83100

PROFILO
COMPENSATORE FISSO

Peso: 1727 g/m
Perim. in vista: 122 mm

Jx cm⁴ 14.73
Jy cm⁴ 81.26
Wx cm³ 4.09
Wy cm³ 16.92

Squadretta
Allineamento esterna

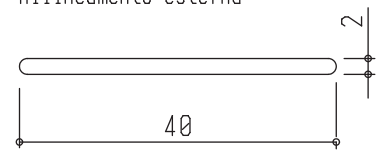

BARRA RETTANGOLARE CON
SPIGOLI RAGGIATI 40x2

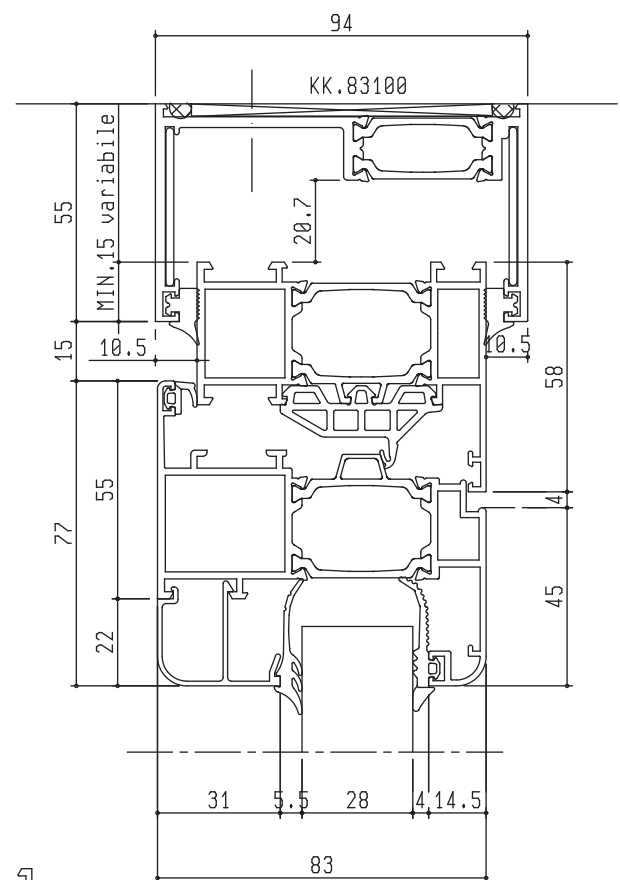
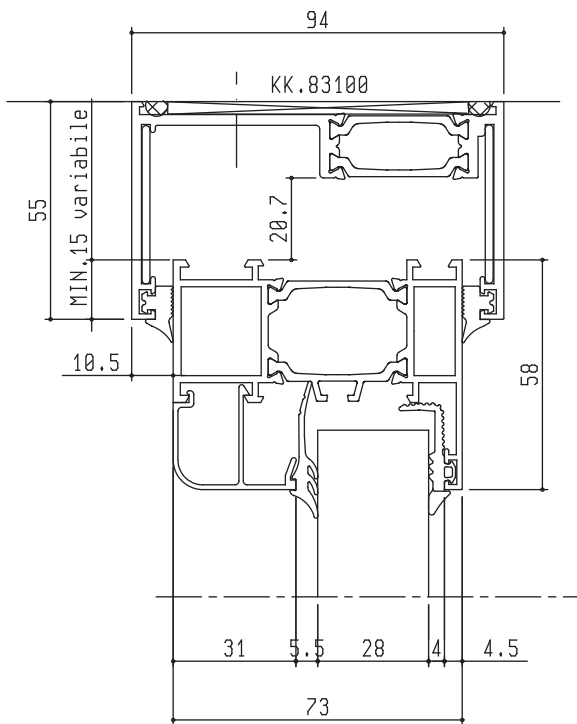

KK.83007

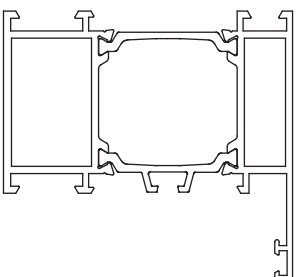

KK.83001

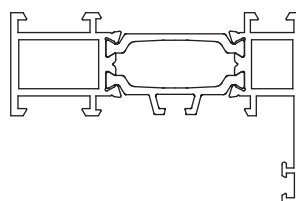

ALTERNATIVE CON I TELAI FISSI COMPLANARI

KK.83209

TELAIO IMBOTTE

Peso: 3165 g/m
Perim. in vista: 266 mm

Jx cm⁴ 308.70
Jy cm⁴ 73.20
Wx cm³ 39.53
Wy cm³ 9.53

- Squadretta Interna AK.83703
- Squadretta Esterna AK.83709
- Squadretta Allineamento Esterna AK.83718
- Squadretta esterna AK.83701
- Squadretta Allineamento Esterna AK.94028

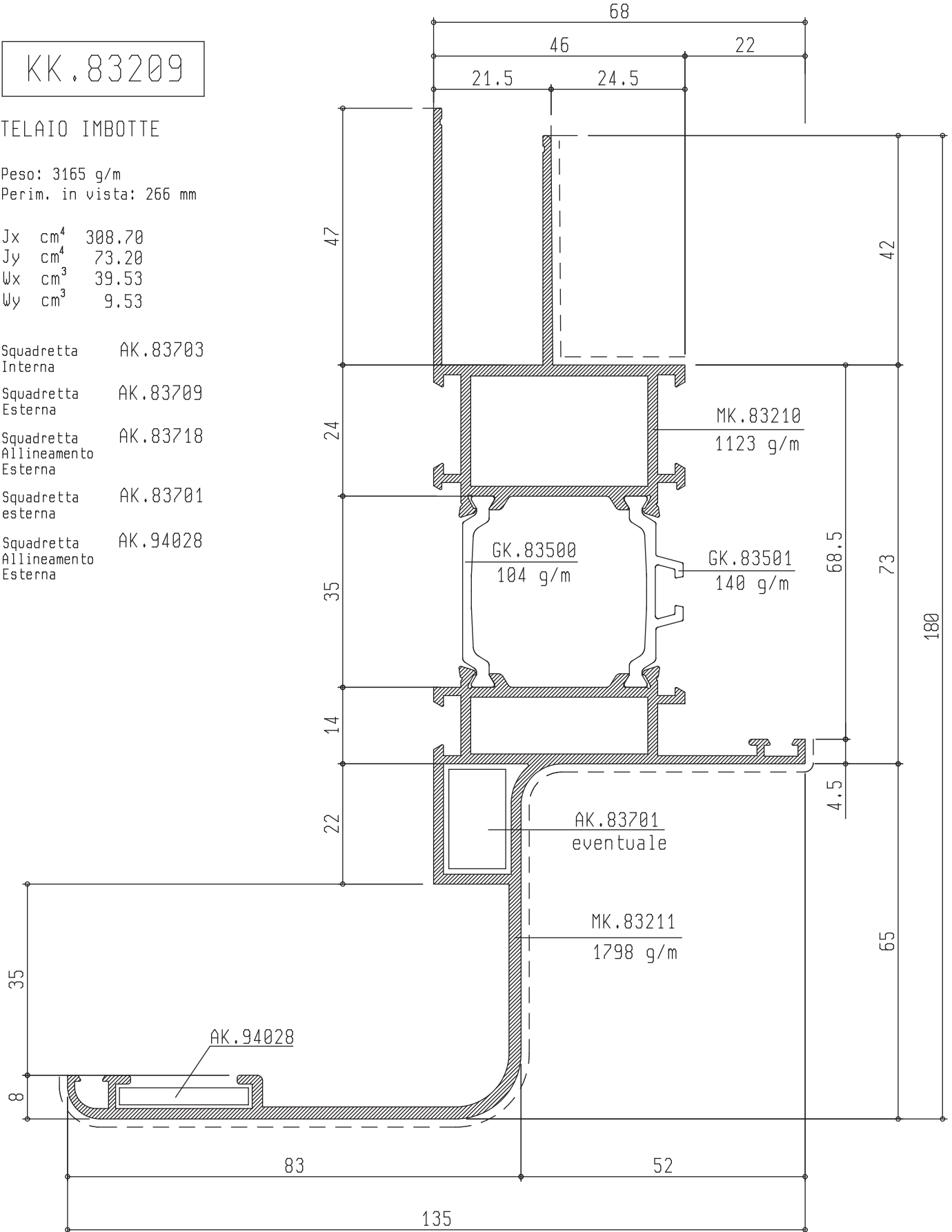

NB. NON PUO' ESSERE LAVORATO NELLA PUNZONATRICE

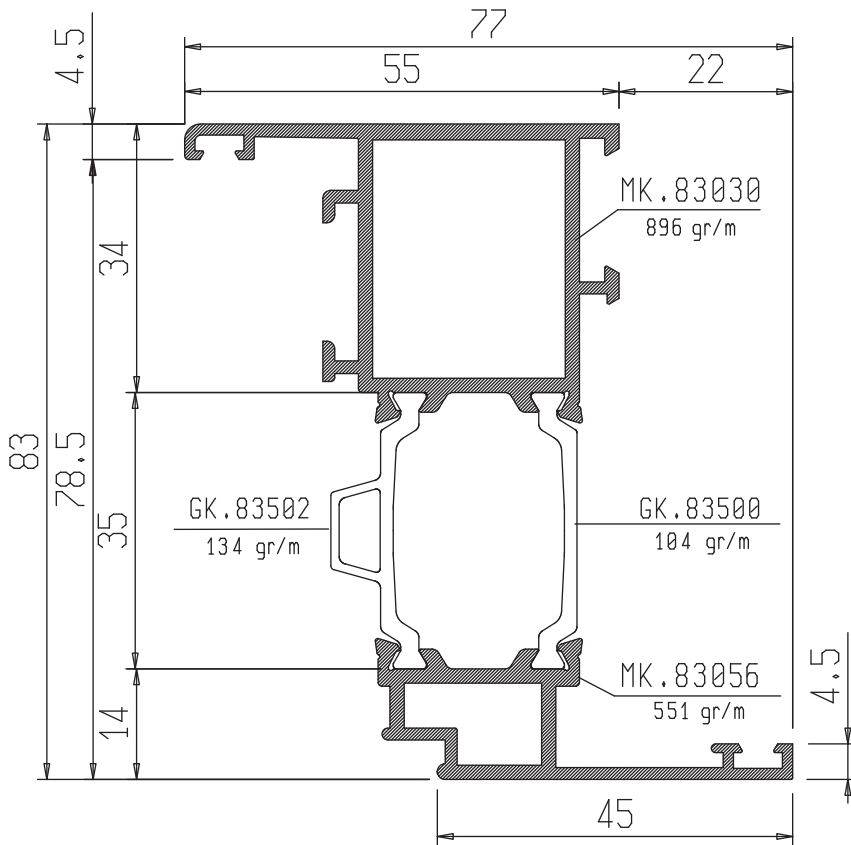

KK.83055

TELAIO MOBILE "Z" 55/45 mm

Peso: 1685 g/m
Perim. in vista: 121 mm

Jx cm⁴ 52.22
Jy cm⁴ 12.92
Wx cm³ 11.81
Wy cm³ 3.47

Squadretta Interna AK.83705

Squadretta Esterna AK.83711

Squadretta Allineamento AK.83725

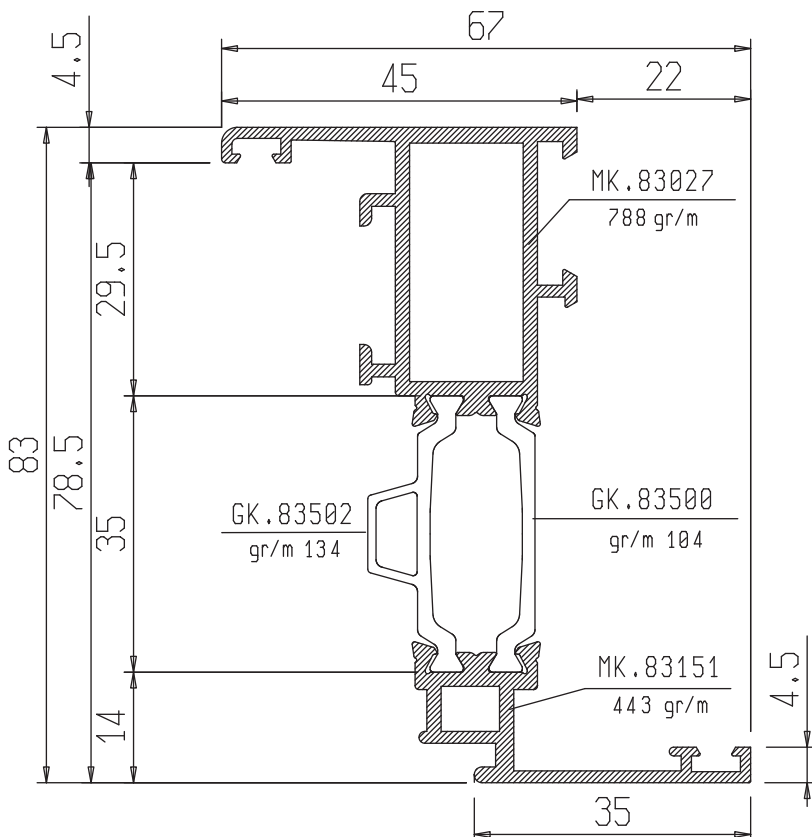

KK.83150

TELAIO MOBILE "Z" 45/35 mm

Peso: 1469 g/m
Perim. in vista: 109 mm

Jx cm⁴ 43.05
Jy cm⁴ 7.25
Wx cm³ 9.38
Wy cm³ 2.25

Squadretta Interna AK.83704

Squadretta Esterna AK.83710

Squadretta Allineamento AK.83725

FERMAVETRI

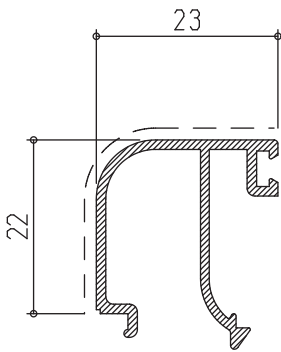

EK.13086

Peso: 275 g/m
Perim. in vista: 41 mm

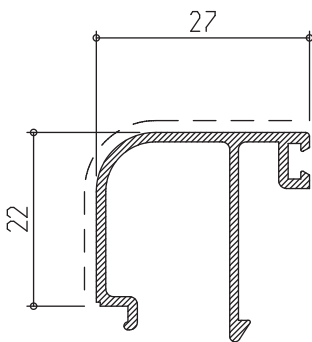
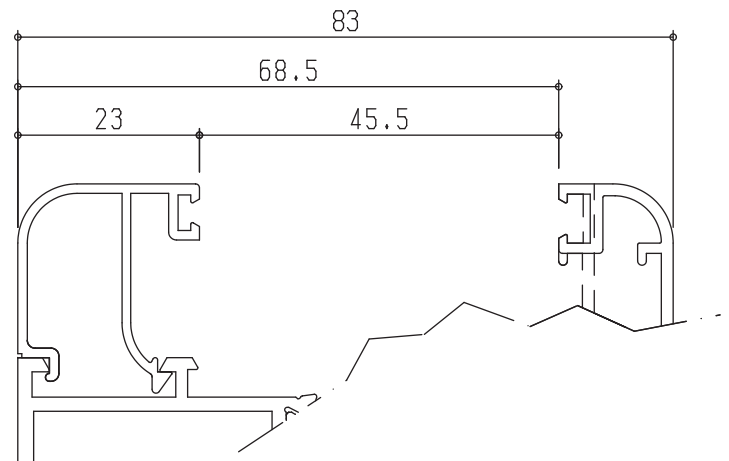

EK.16102

Peso: 285 g/m
Perim. in vista: 45 mm

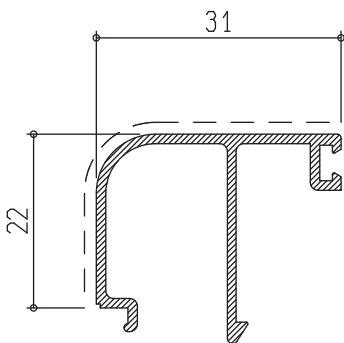
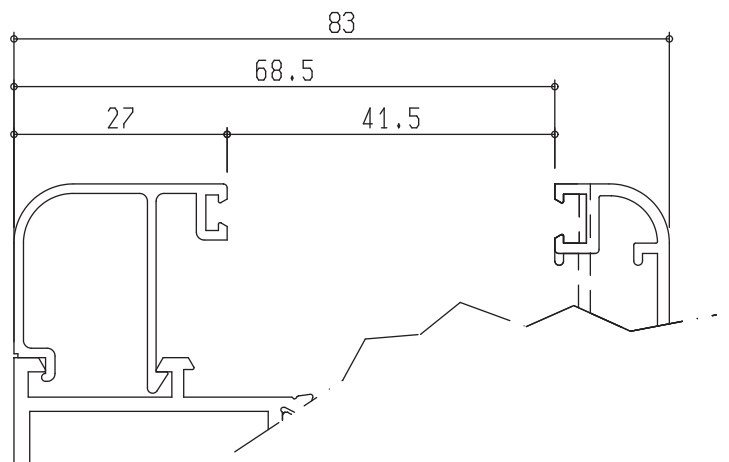

EK.13087

Peso: 296 g/m
Perim. in vista: 49 mm

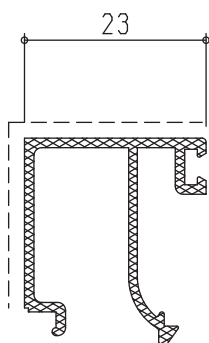
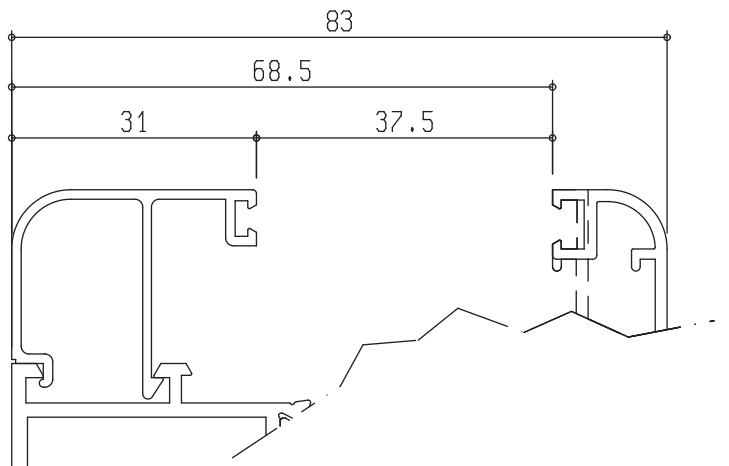

EK.13097

Peso: 285 g/m
Perim. in vista: 44 mm

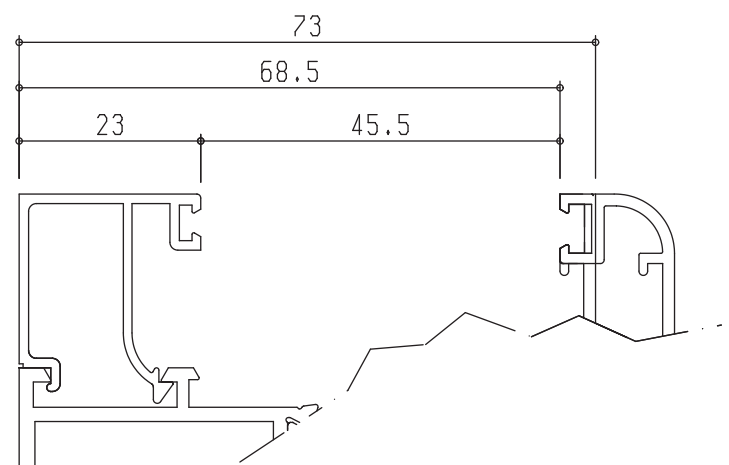

DATA	SCHEDA
Maggio 2016	SP20

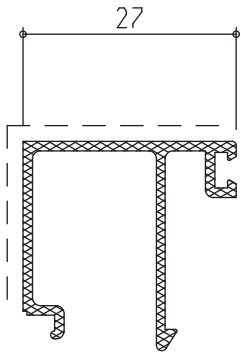

EK.16101

Peso: 295 g/m
Perim. in vista: 48 mm

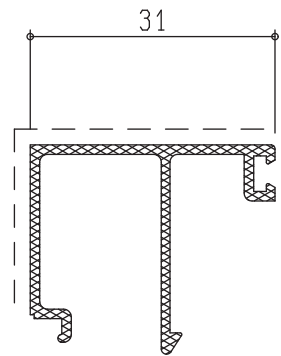
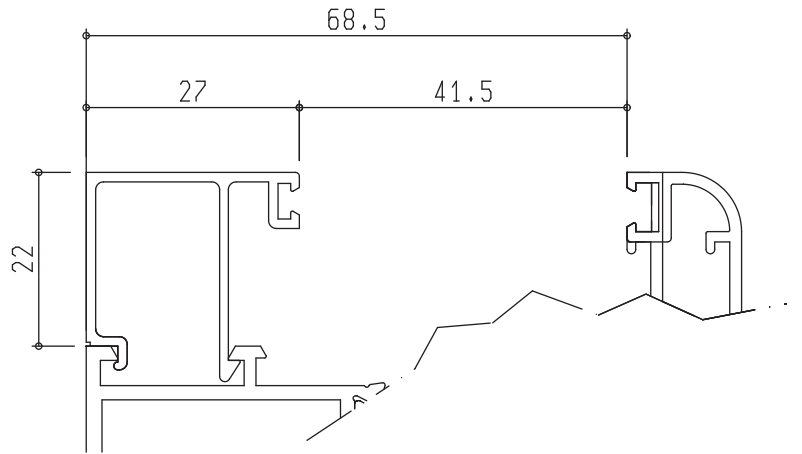

EK.13096

Peso: 299 g/m
Perim. in vista: 52 mm

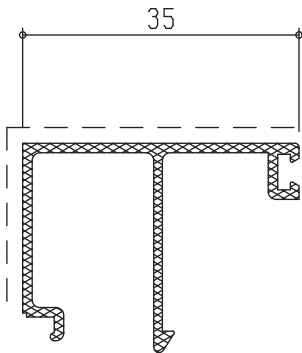
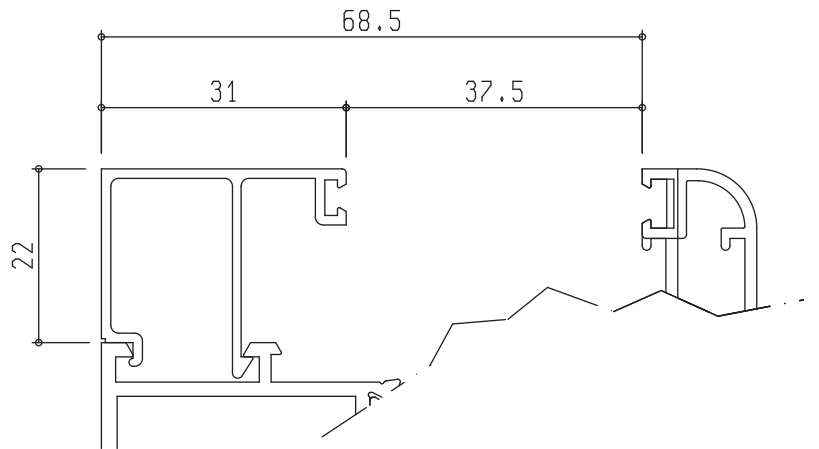

9097

Peso: 308 g/m
Perim. in vista: 56 mm

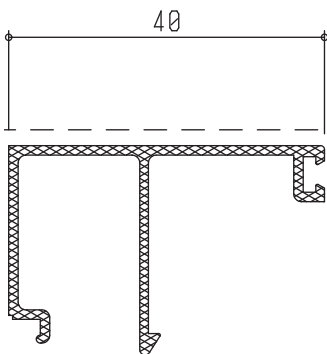
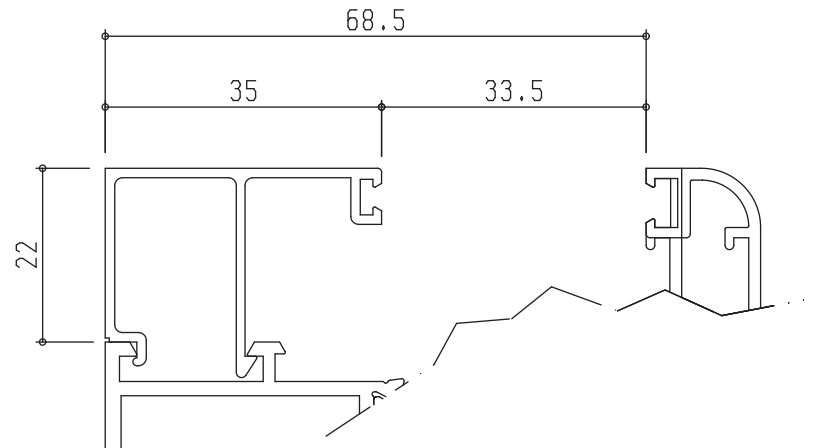

9175

Peso: 318 g/m
Perim. in vista: 61 mm

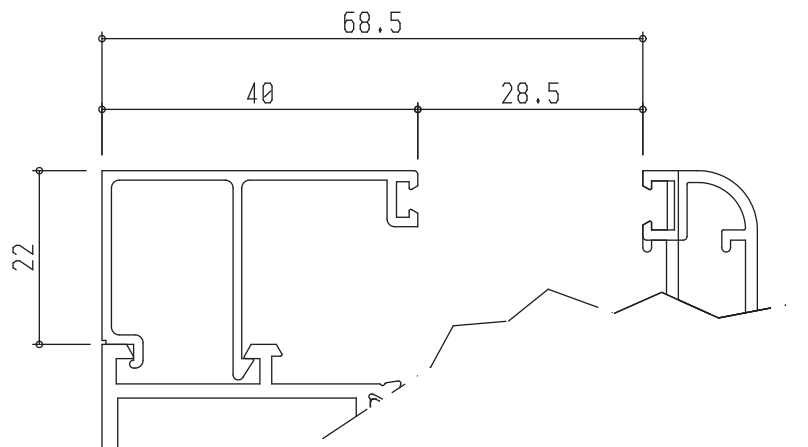

MATRICI COMPLEMENTARI

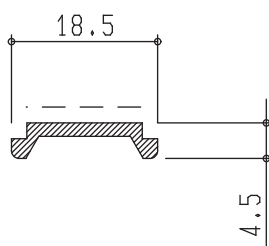

ZK.09528

ASTINA

Peso: 105 g/m
Perim. in vista: 15 mm

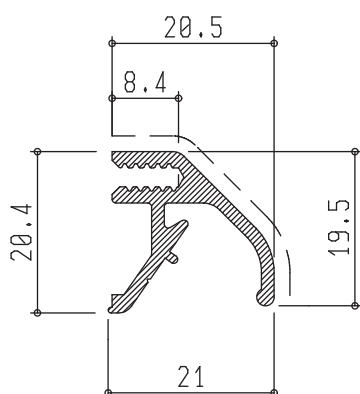

EK.14505

GOCCIOLATOIO

Peso: 299 g/m
Perim. in vista: 32 mm

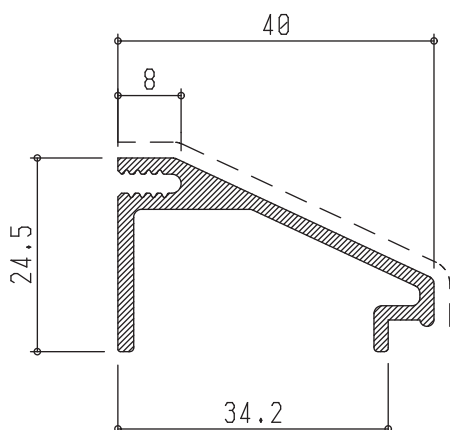

EK.16588

SCIVOLO PER
SOGLIA RIBASSATA

Peso: 470 g/m
Perim. in vista: 50 mm

MATRICI COMPLEMENTARI

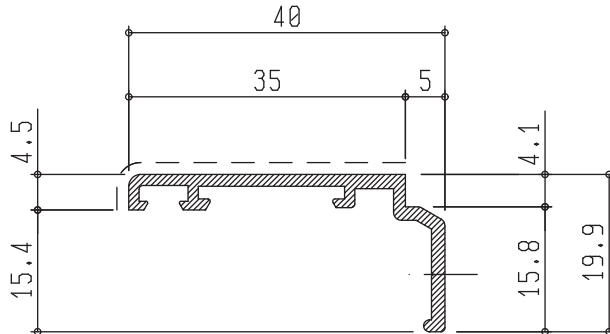

EK.83170

ALETTA DI BATTUTA 35 mm
COMPLANARE

Peso: 289 g/m
Perim. in vista: 40 mm

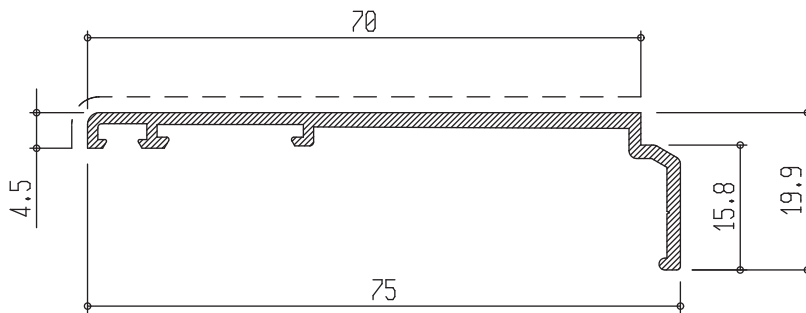

EK.83262

ALETTA DI BATTUTA 70 mm
COMPLANARE

Peso: 471 g/m
Perim. in vista: 75 mm

Esempio di applicazione

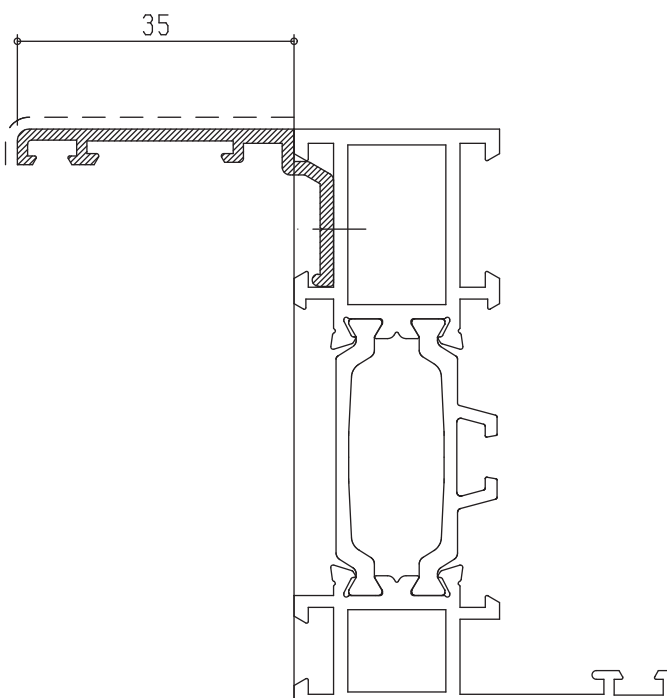

NODI TIPO

maggiormente rappresentativi

- *Sezioni orizzontali e verticali
in scala 1:1 (Schede NS)*
- *Sezioni orizzontali e verticali
in scala 1:1 o in scala 1:2
con applicazioni particolari (Schede NSa)*

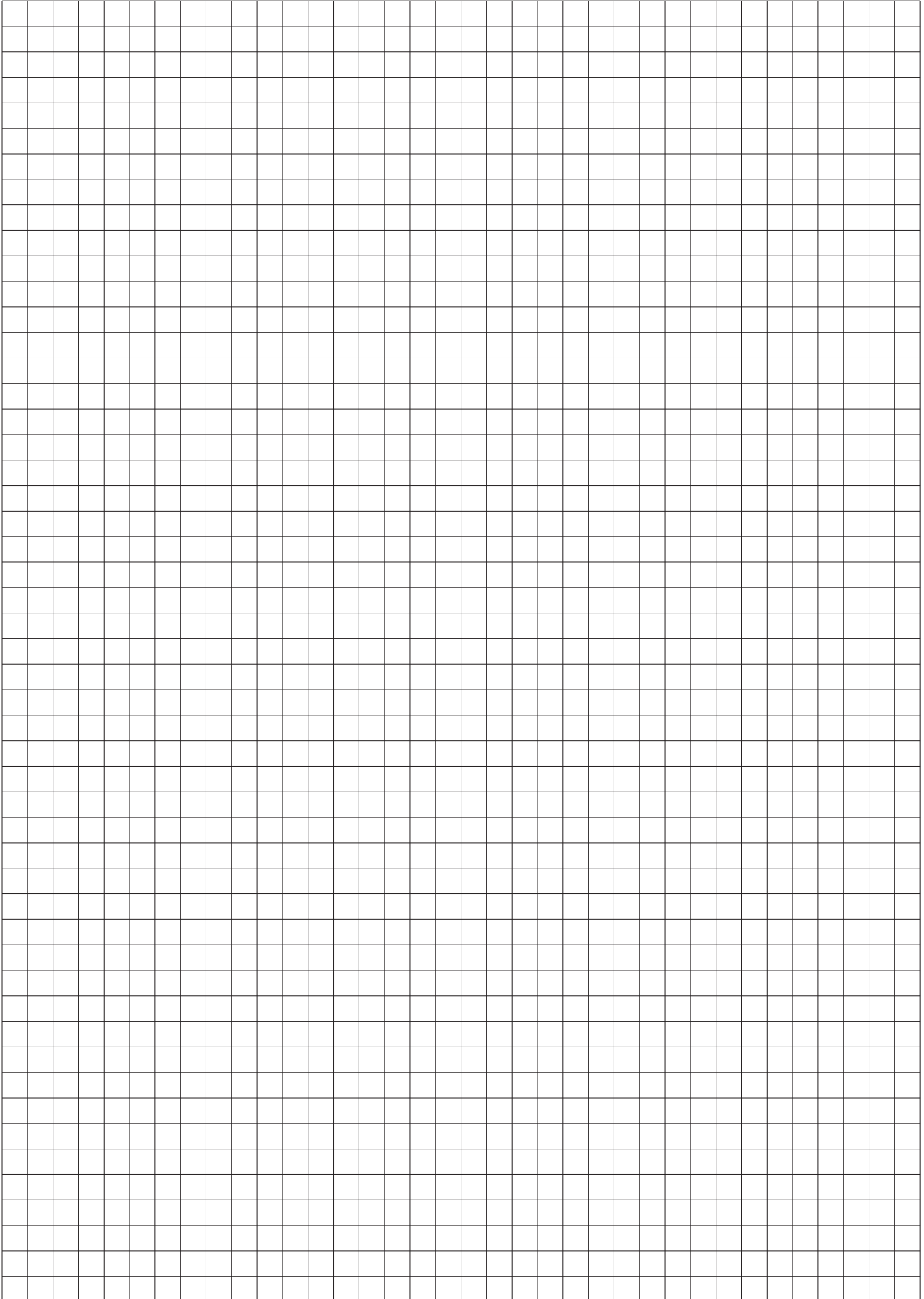

DATA	SCHEDA
Maggio 2016	NS02

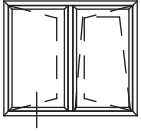

Prospetto
vista esterna

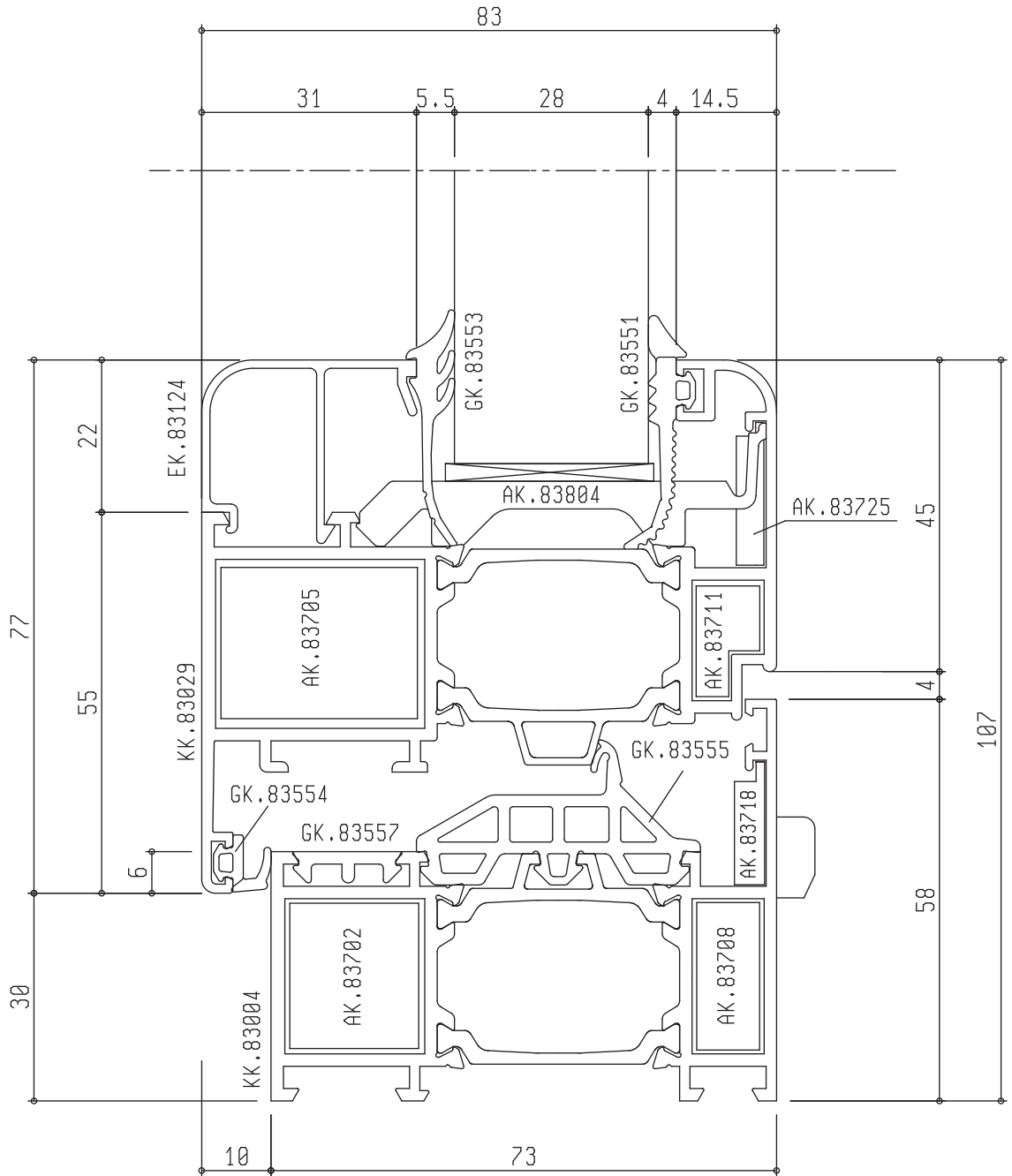



Sistemi

TGP TH73

Soluzione
TONDA

DATA	SCHEDA
Maggio 2016	NS03

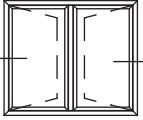

Prospetto
vista esterna

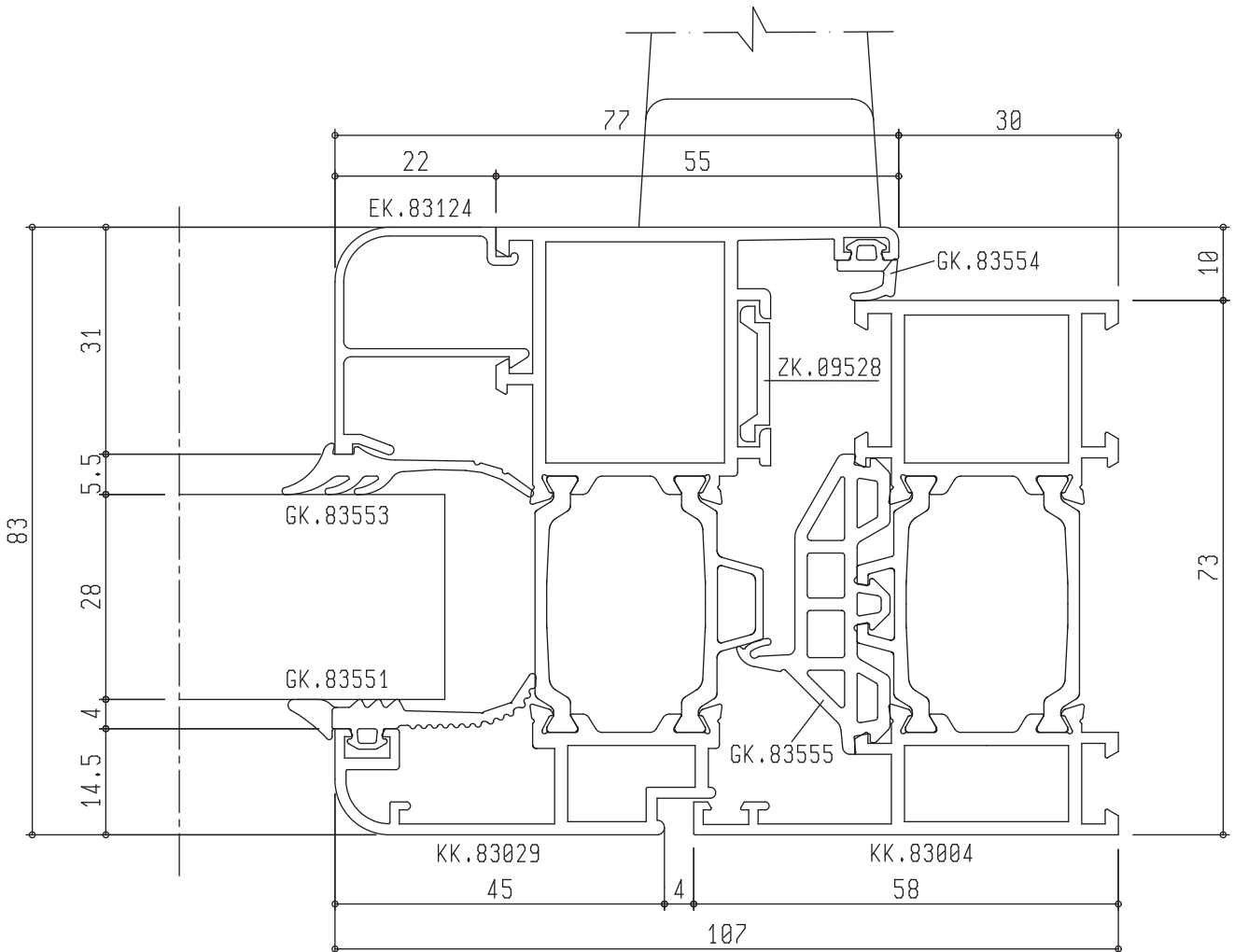
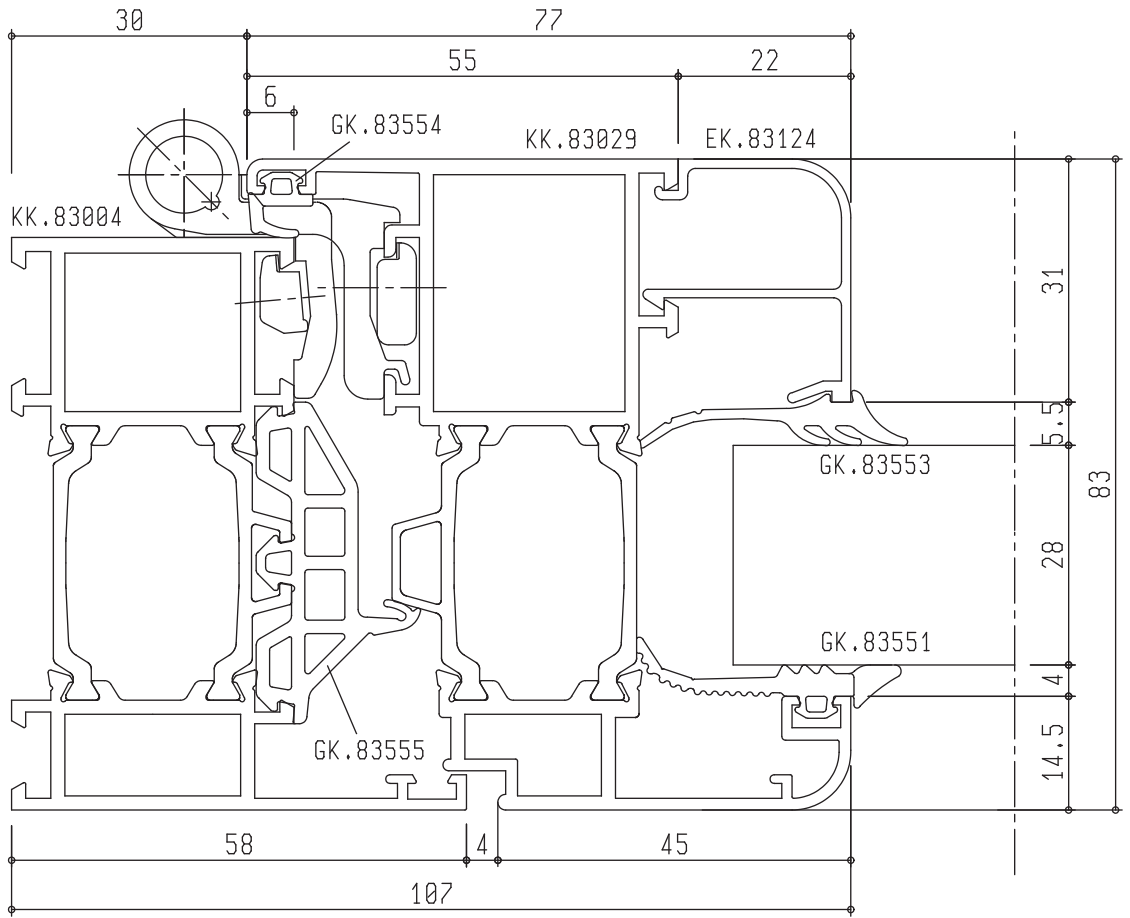



Sistemi

TGP TH73

DATA	SCHEDA
Maggio 2016	NS04

Alta Prestazione Termica

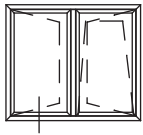

*Prospetto
vista esterna*

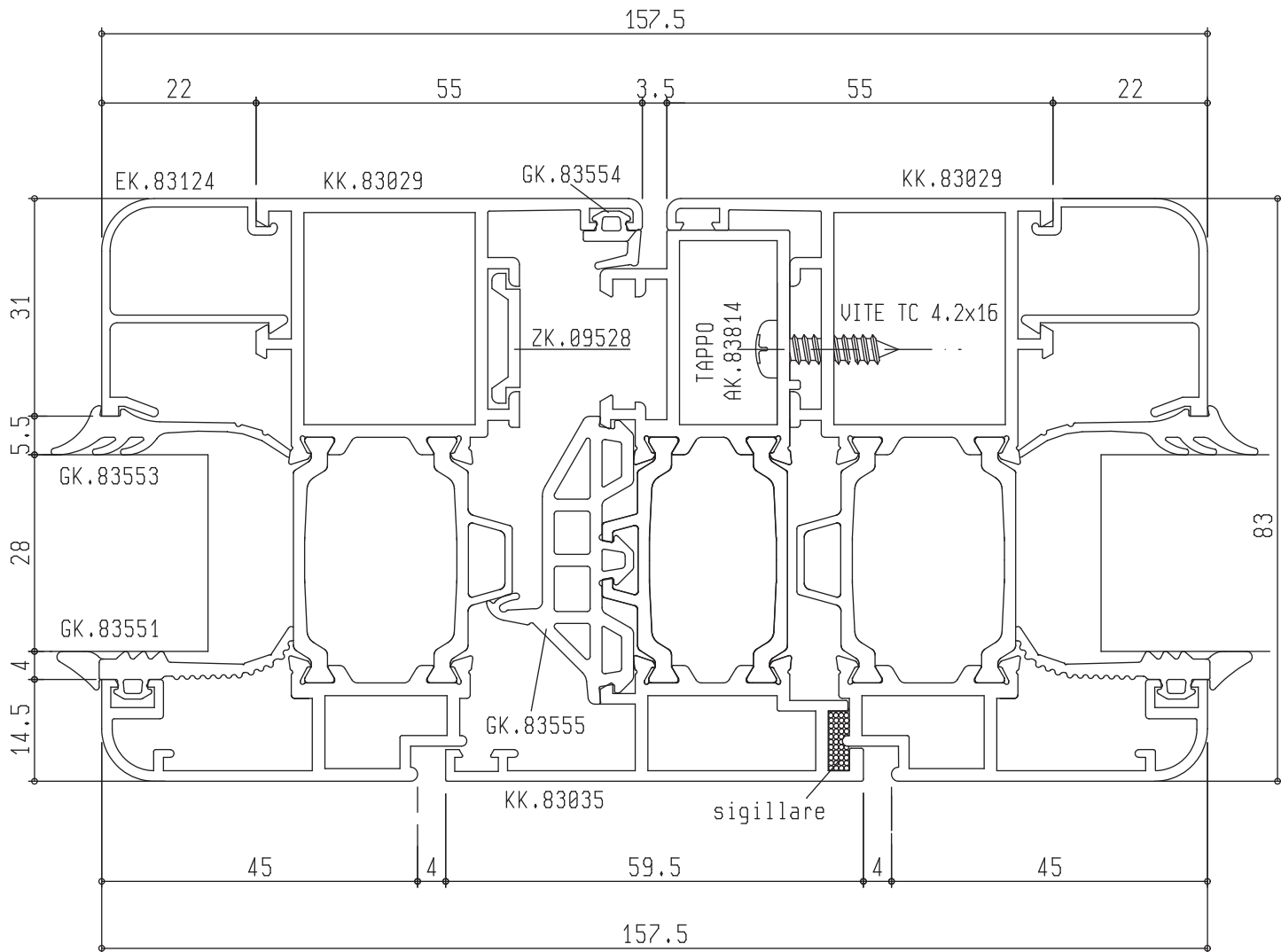



Sistemi

TGP TH73

Soluzione
TONDA

DATA	SCHEDA
Maggio 2016	NS05



Prospetto
vista esterna

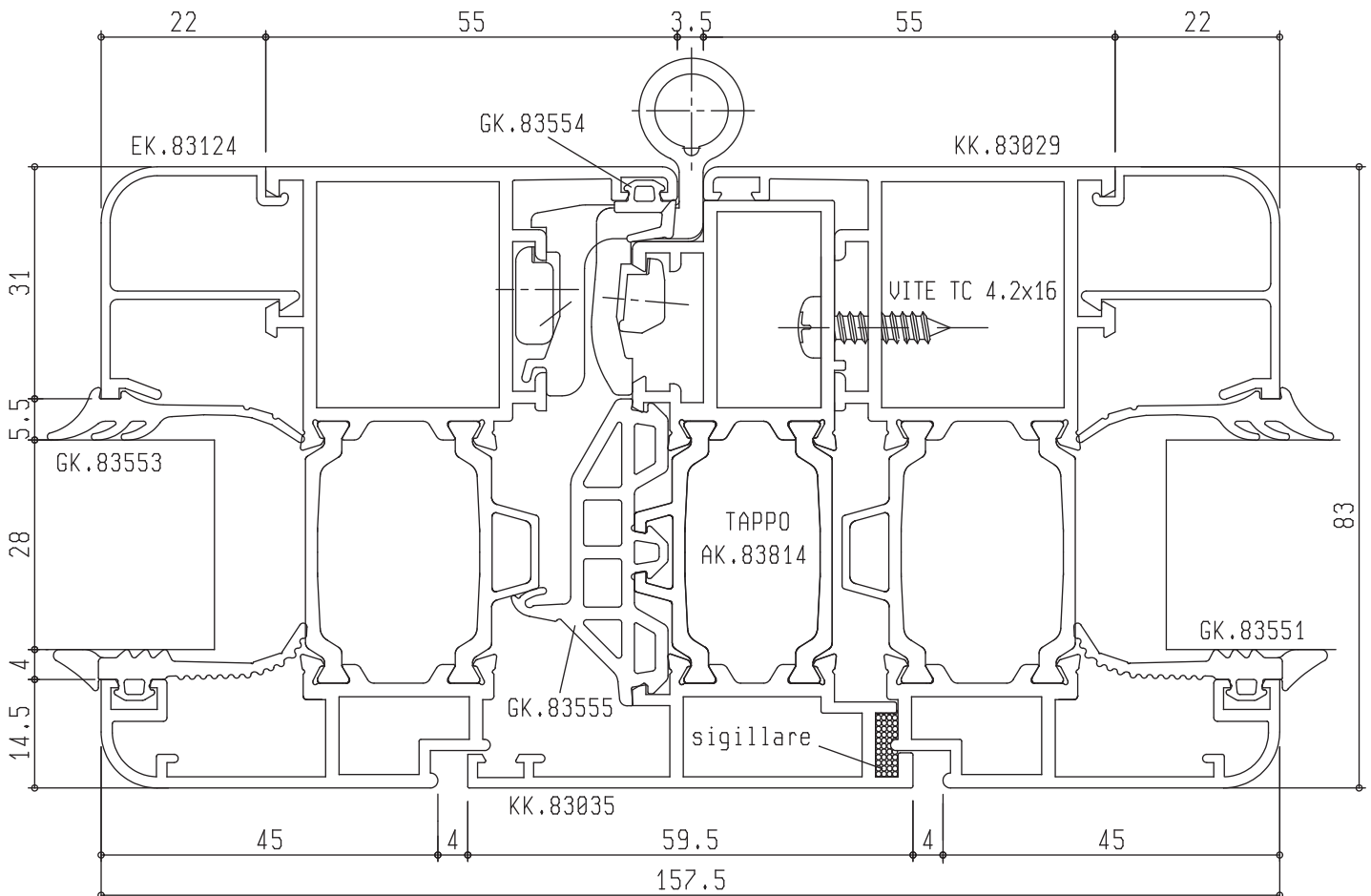
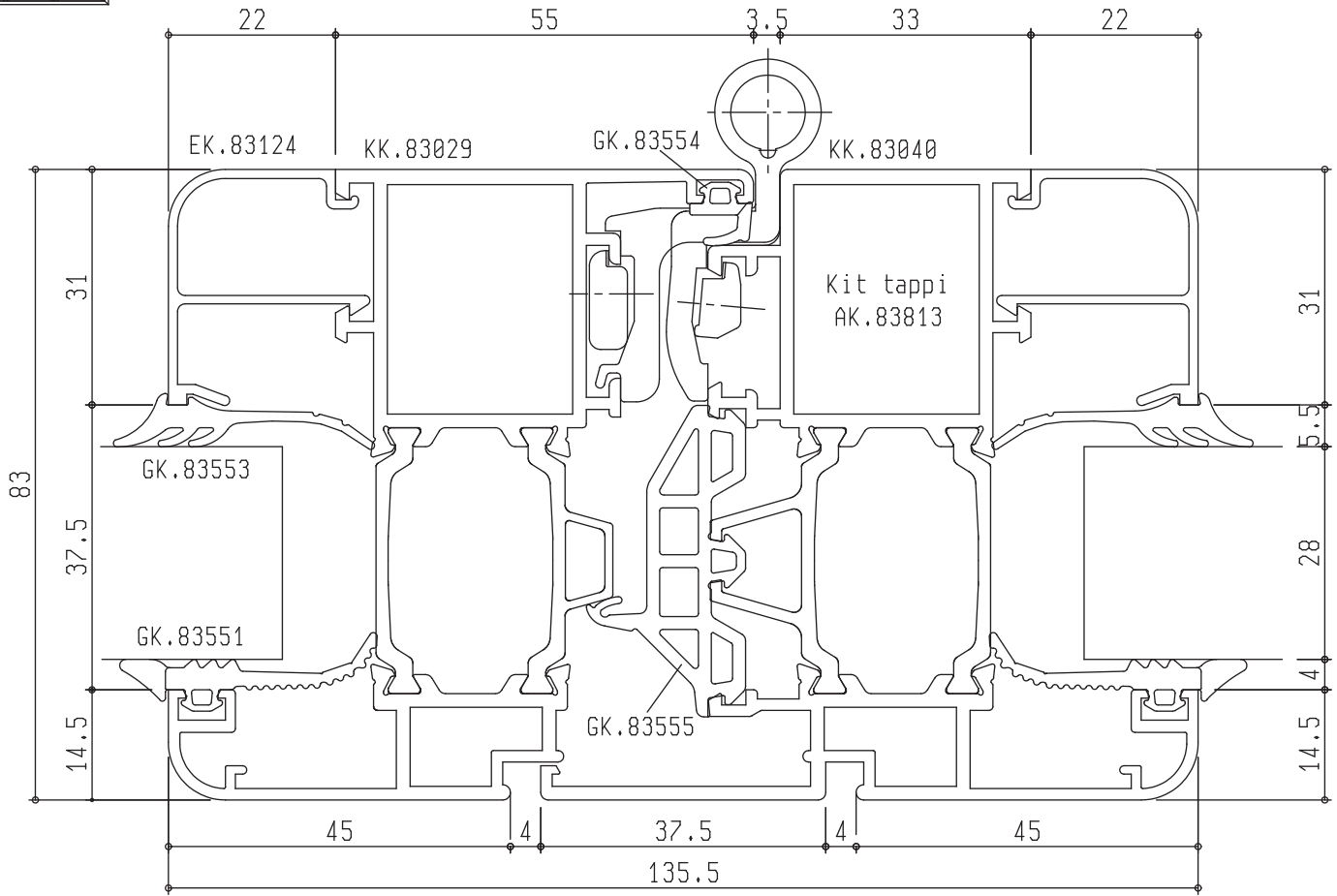

DATA	SCHEDA
Maggio 2016	NS06

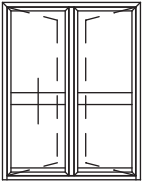

Prospetto
vista esterna

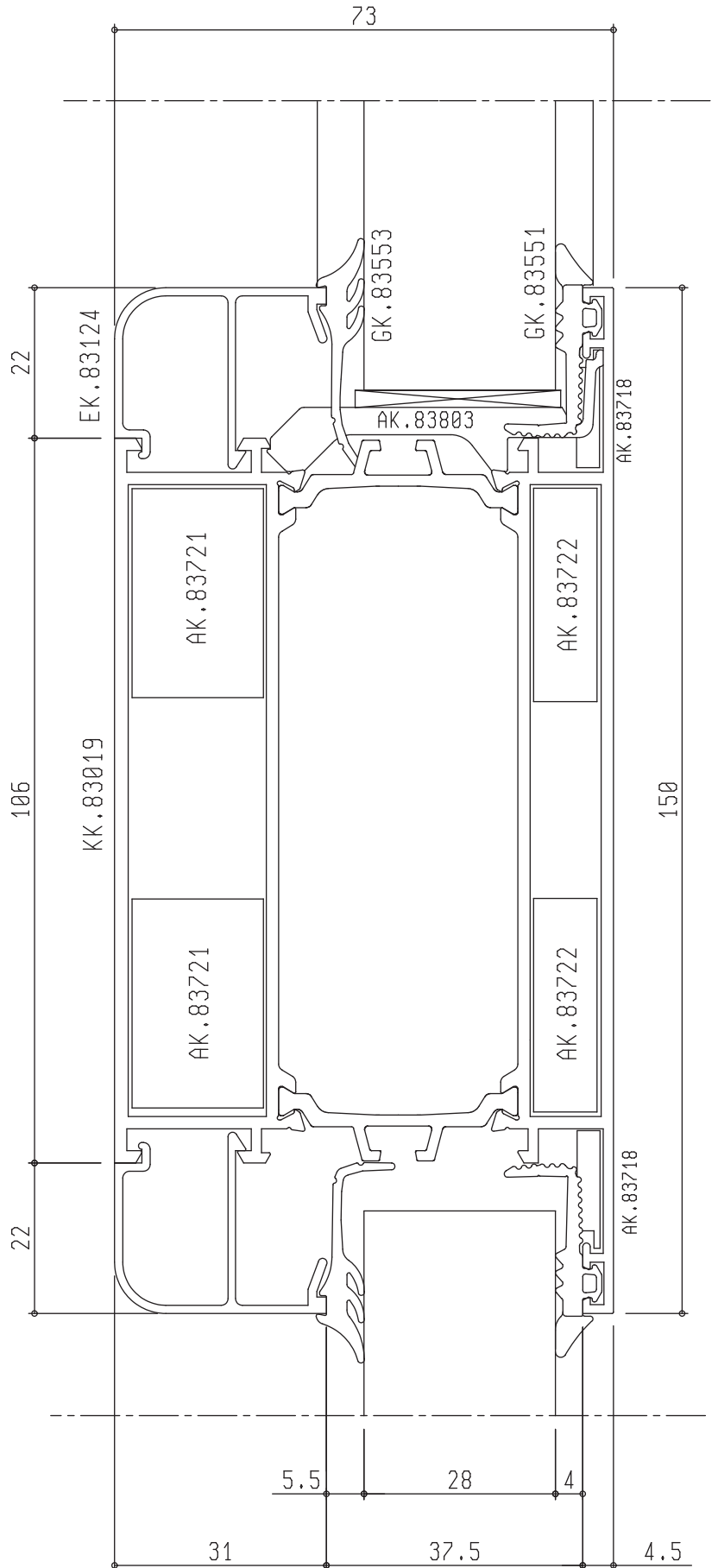
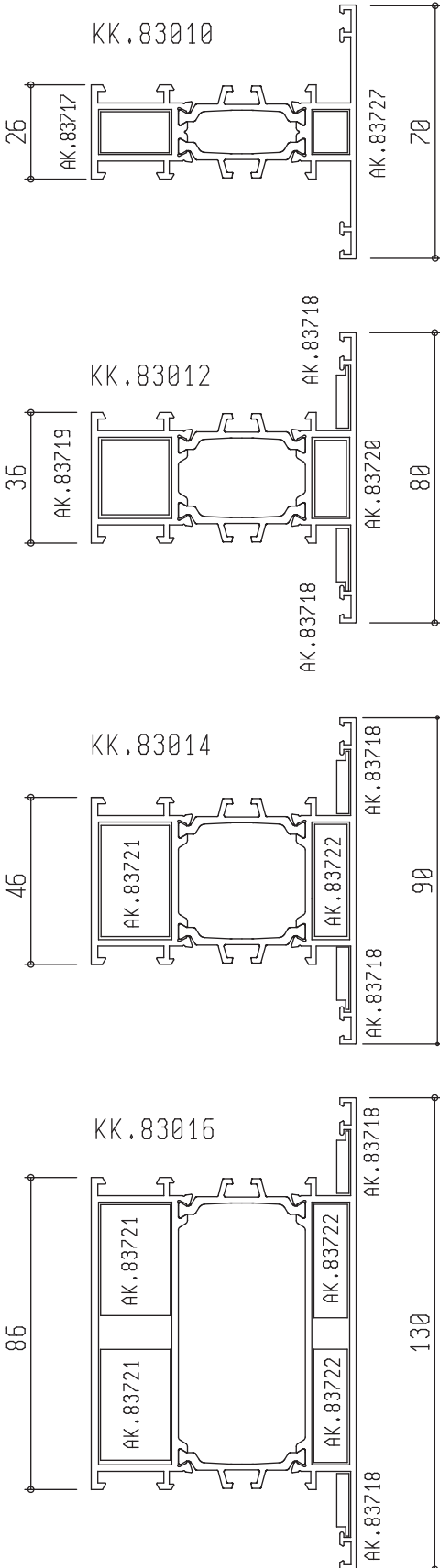

SOLUZIONE CON SOGLIA RIBASSATA A GIUNTO APERTO

NB. NELLA REALIZZAZIONE DI PORTEFINESTRE SI CONSIGLIA
DI UTILIZZARE SEMPRE ANTE MEDIE O GRANDI

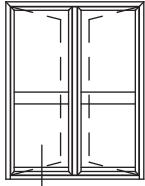

Prospetto
vista esterna

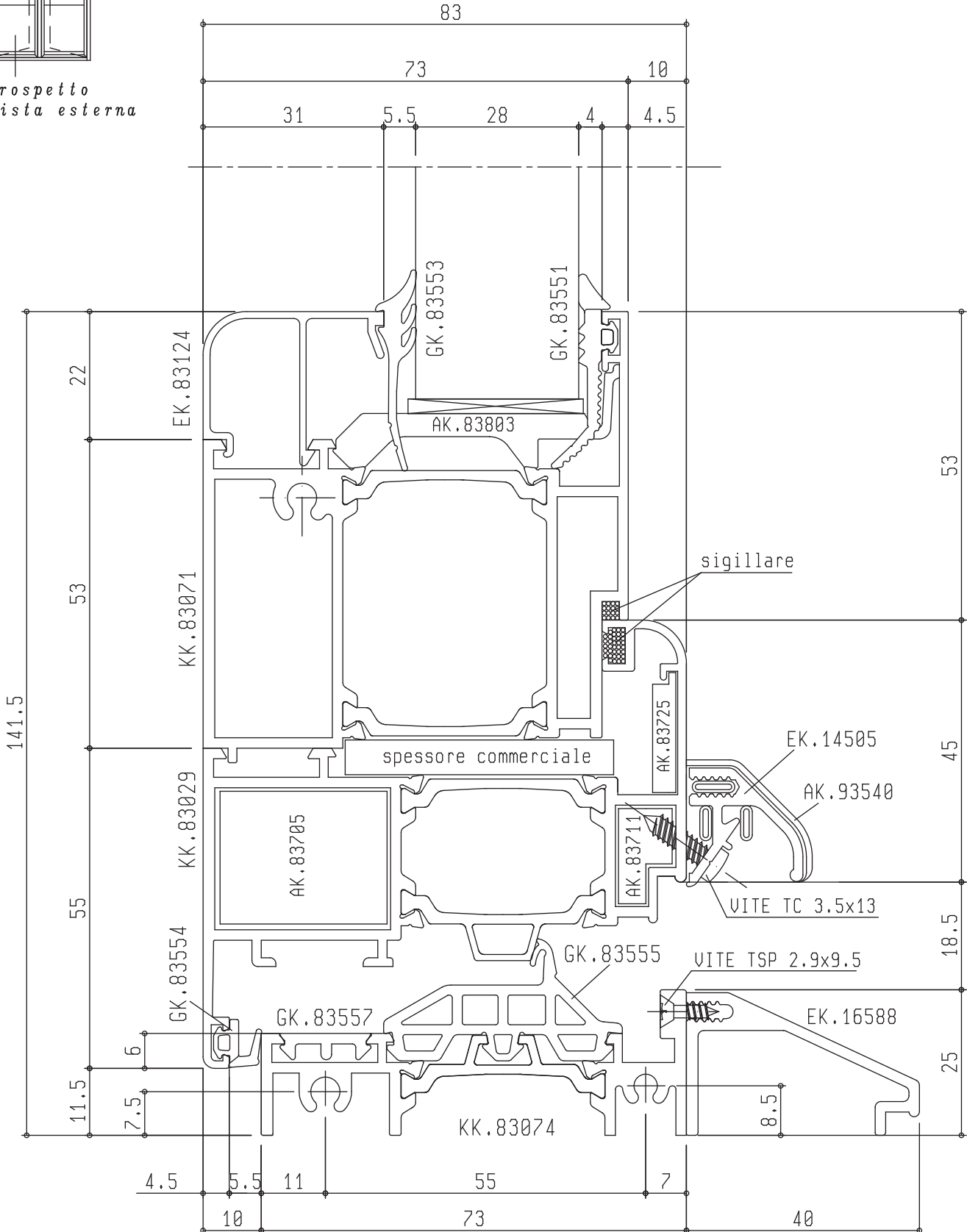

NB. CON QUESTA SOLUZIONE NON E' POSSIBILE L'UTILIZZO DELL'ANTA RIBALTA

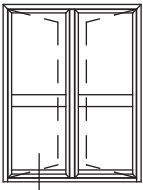

Prospetto
vista esterno

NB. NELLA REALIZZAZIONE DI PORTEFINESTRE SI CONSIGLIA
DI UTILIZZARE SEMPRE ANTE MEDIE O GRANDI

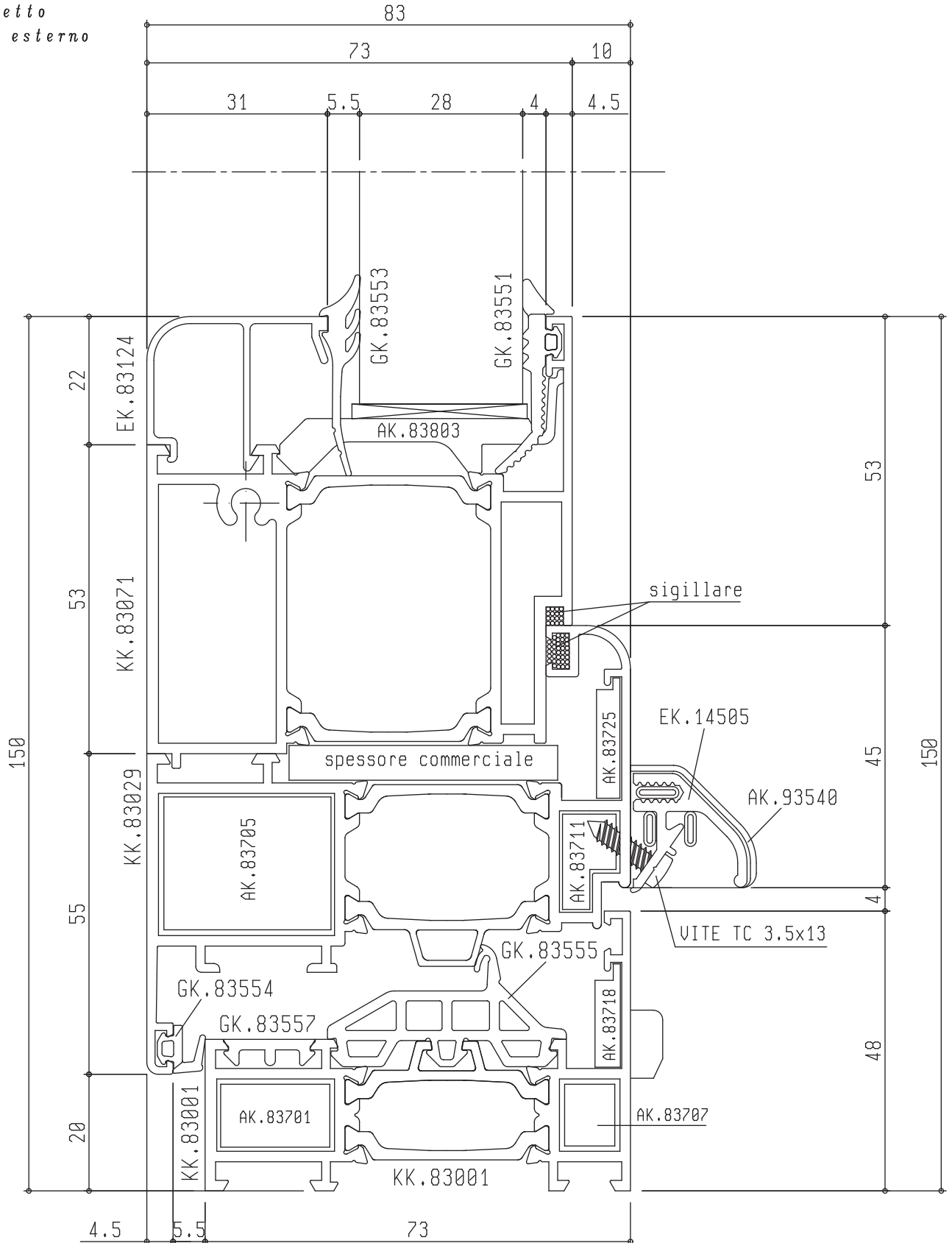



Sistemi

TGP TH73

Soluzione
TONDA

DATA	SCHEDA
Maggio 2016	NS09

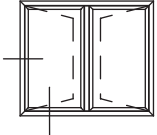

Prospetto
vista esterna

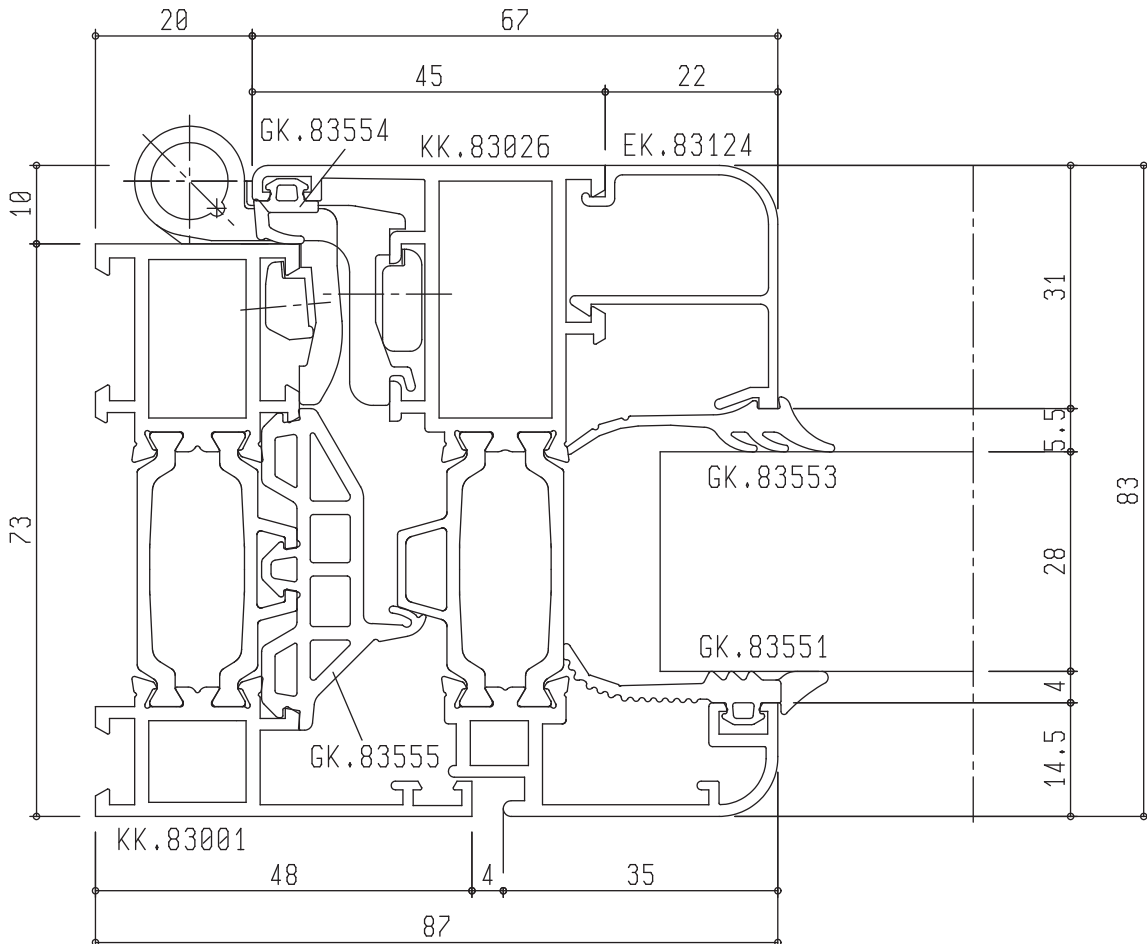
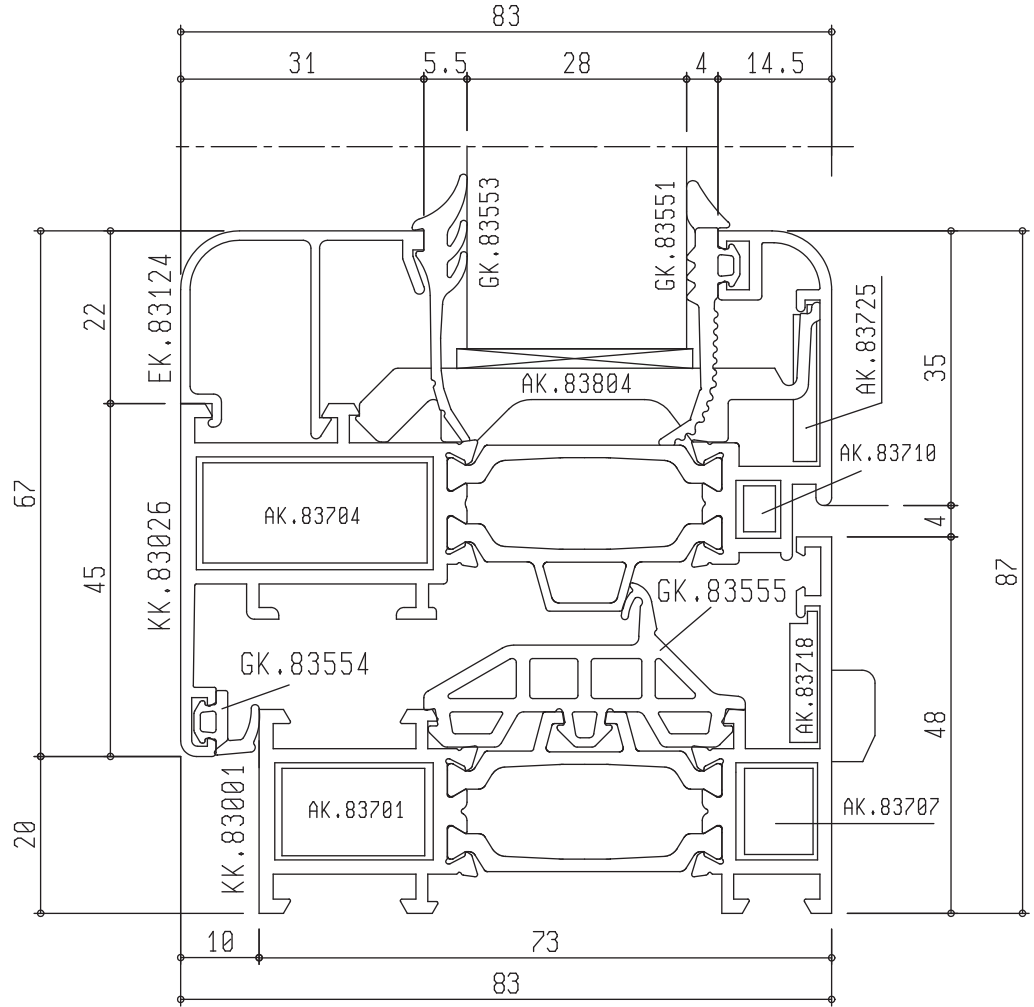

DATA	SCHEDA
Maggio 2016	NS10

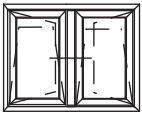

Prospetto
vista esterna

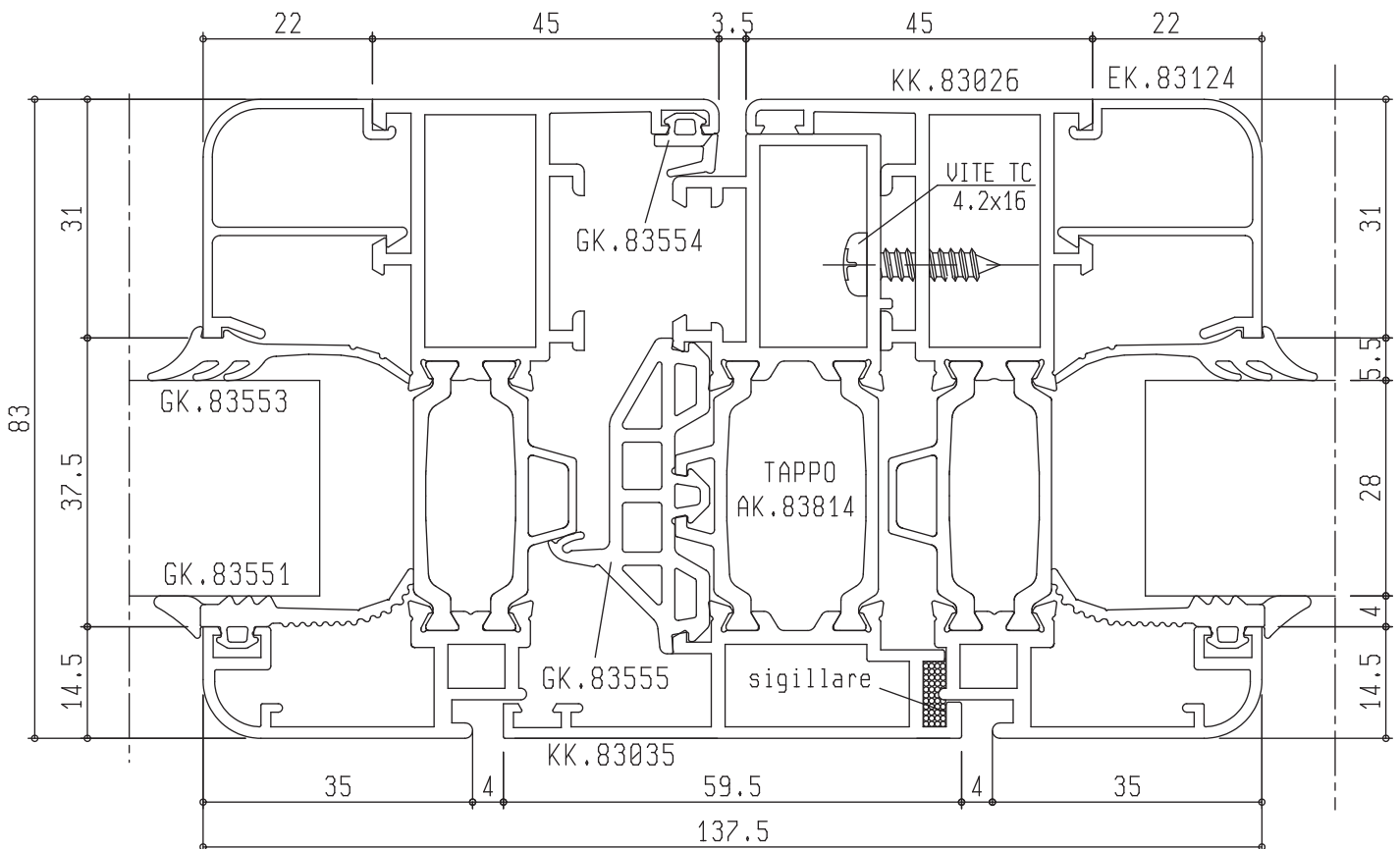
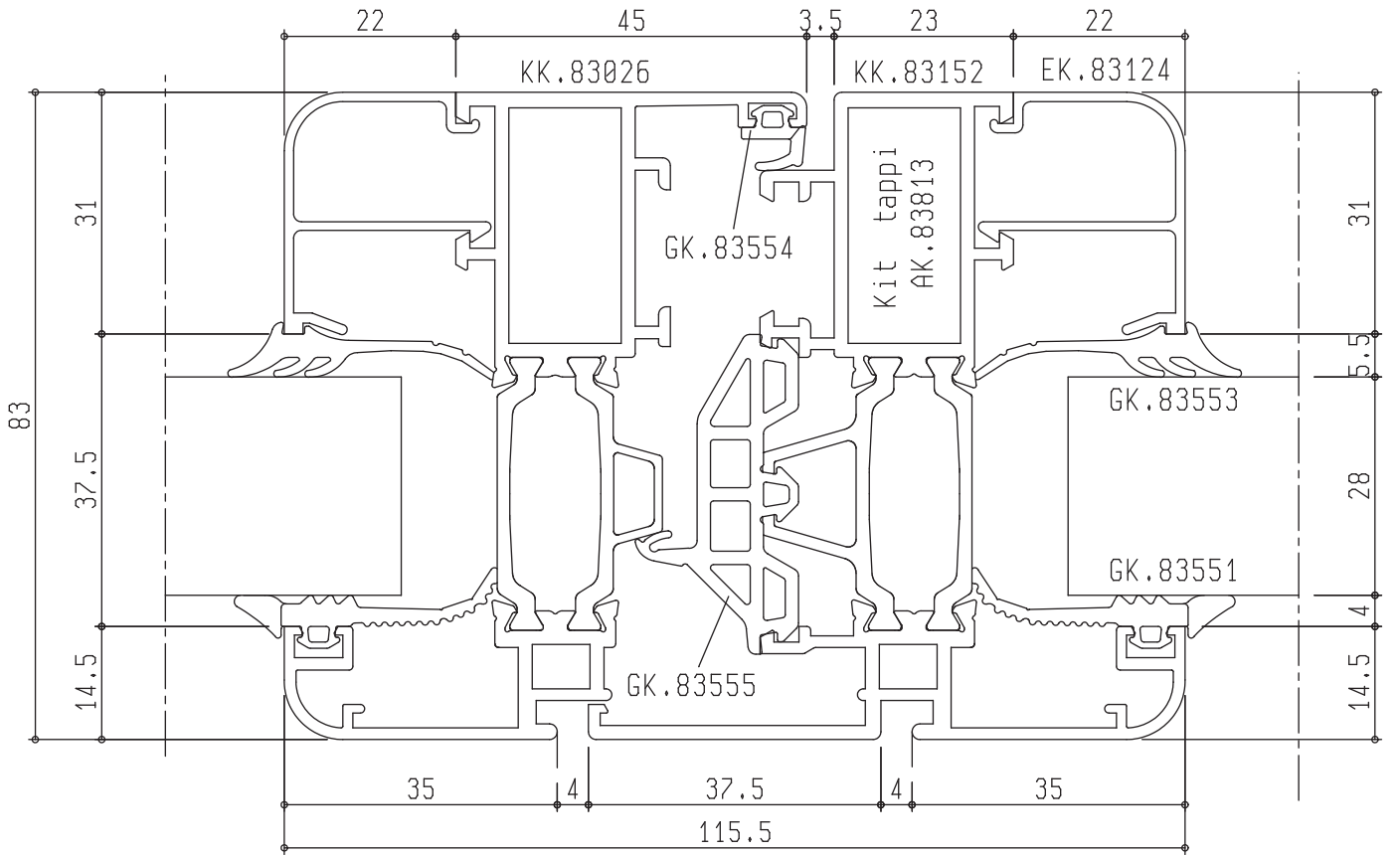

DATA	SCHEDA
Maggio 2016	NS13

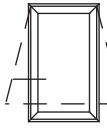

*Prospetto
vista esterna*

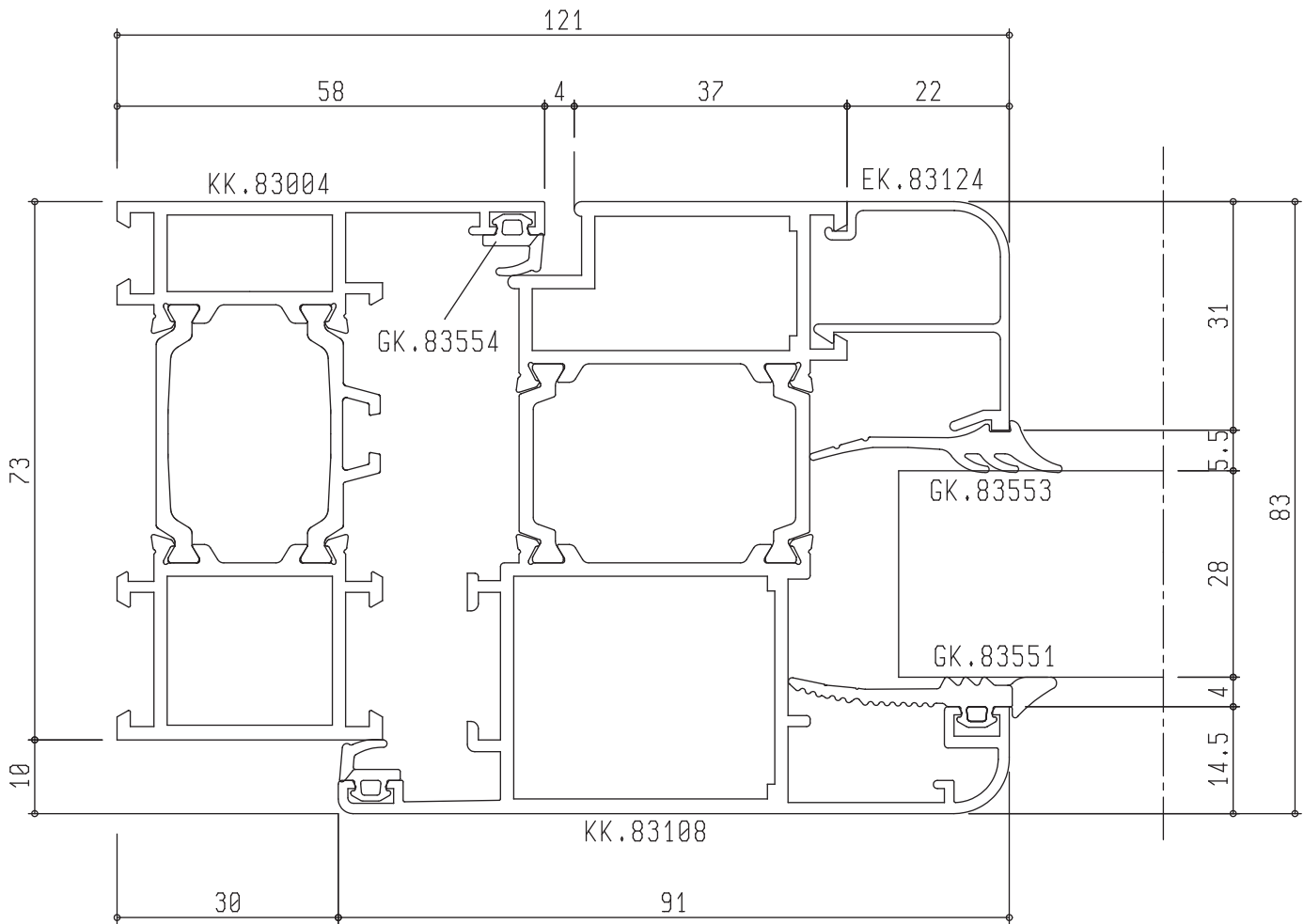

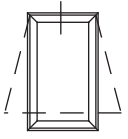

Prospetto
vista esterna

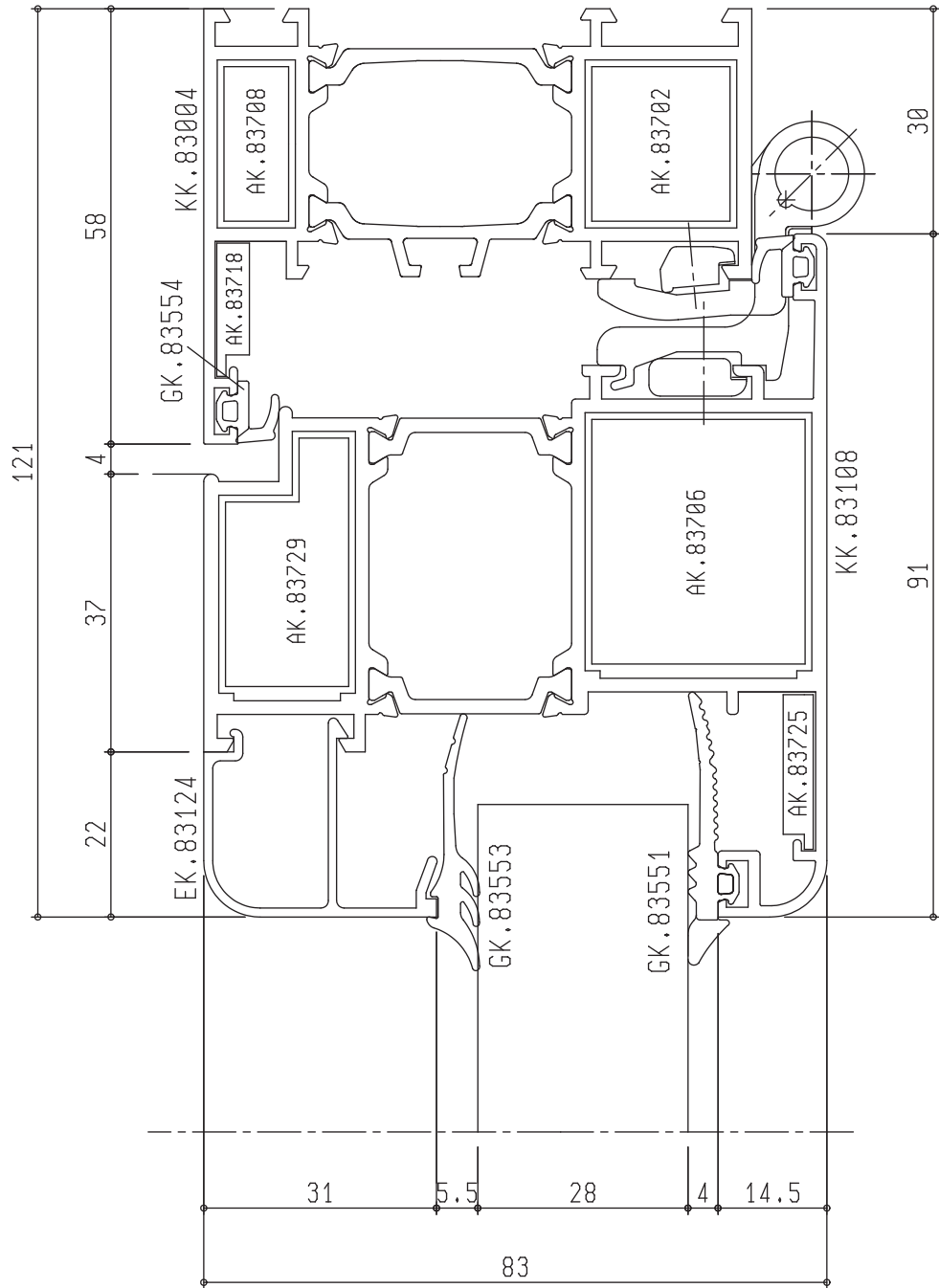

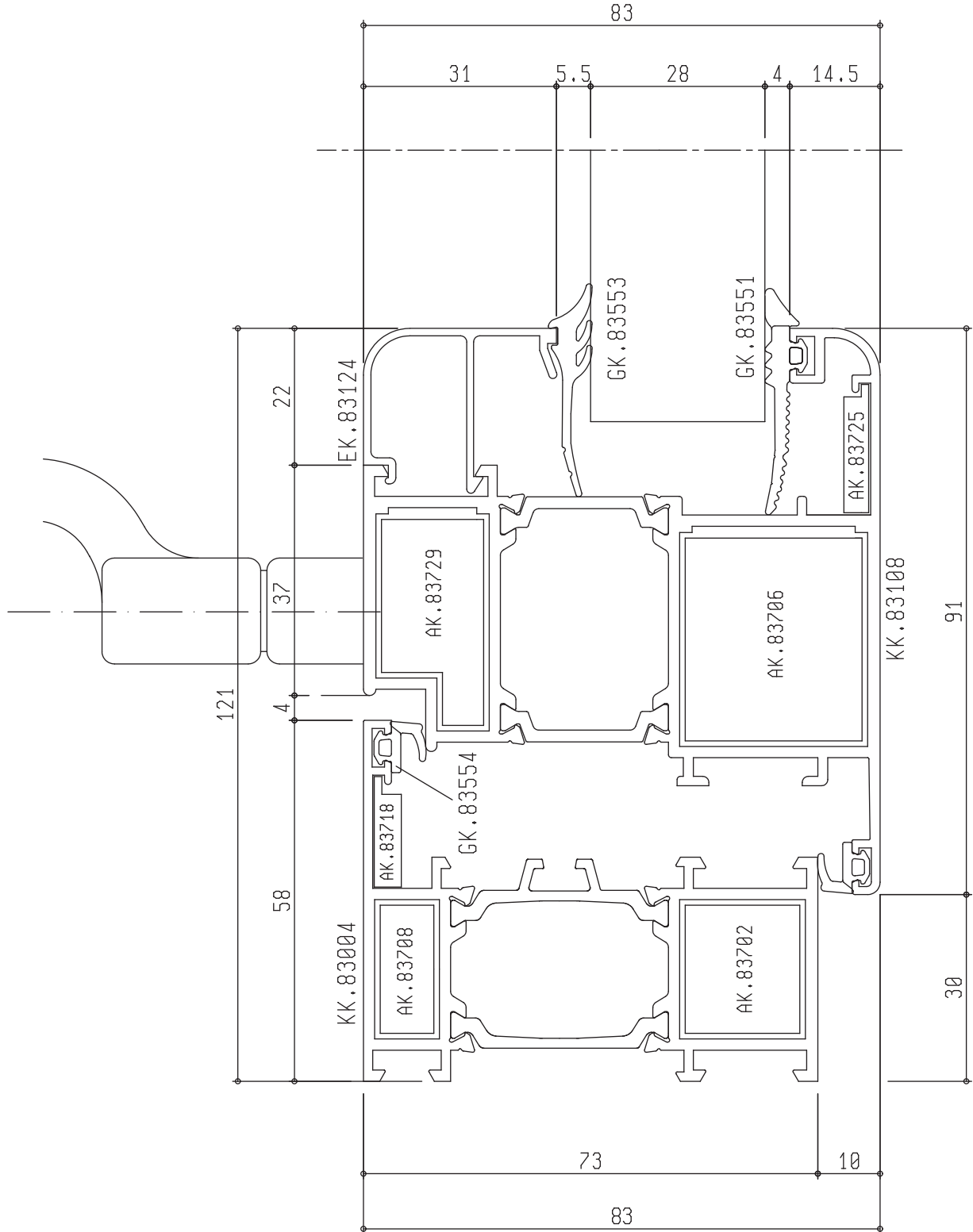

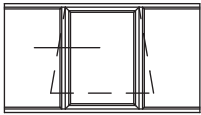

*Prospetto
vista esterna*

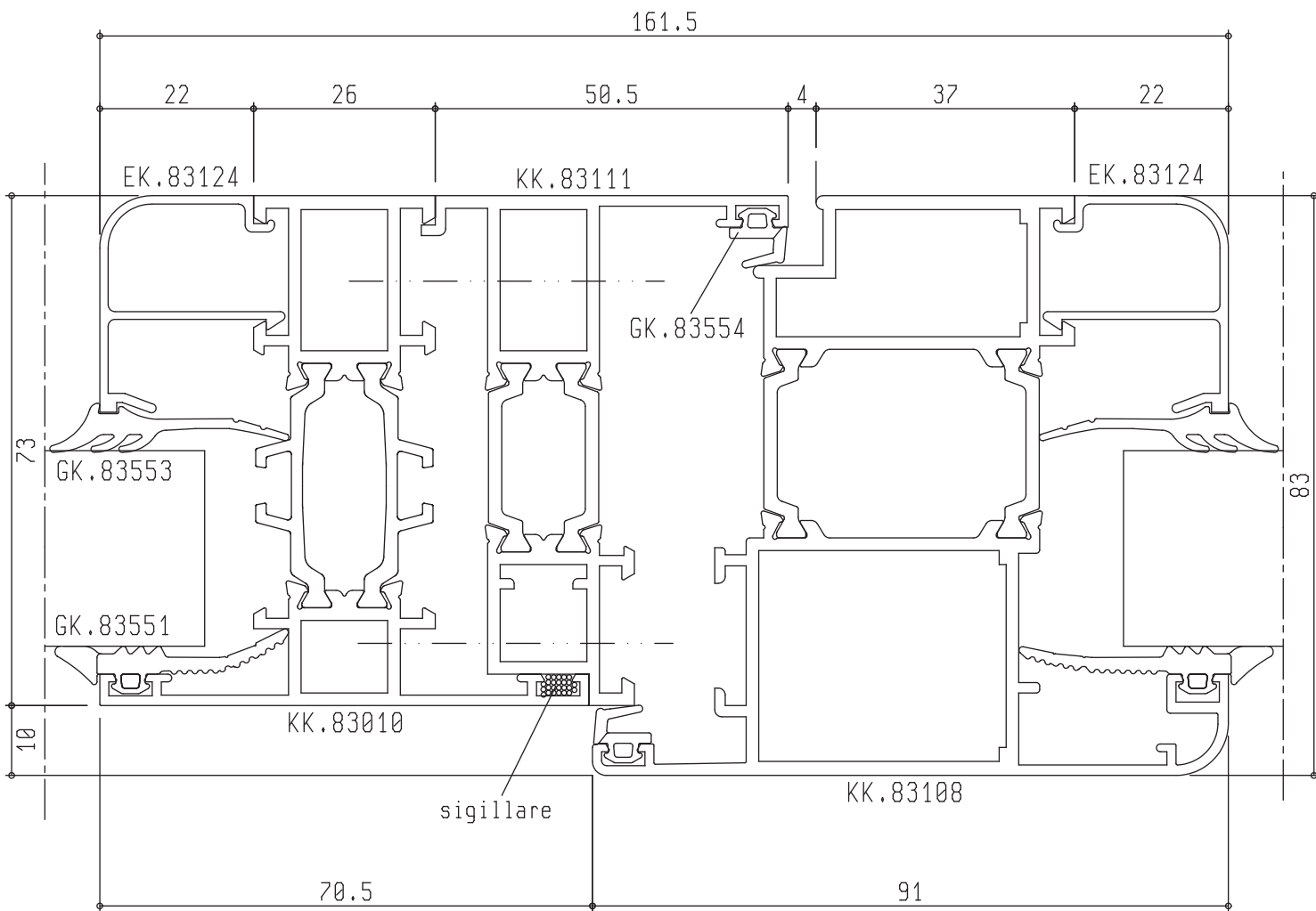



Sistemi

TGP TH73

DATA	SCHEDA
Maggio 2016	NS17

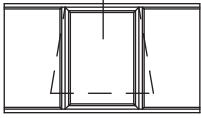

Prospetto
vista esterna

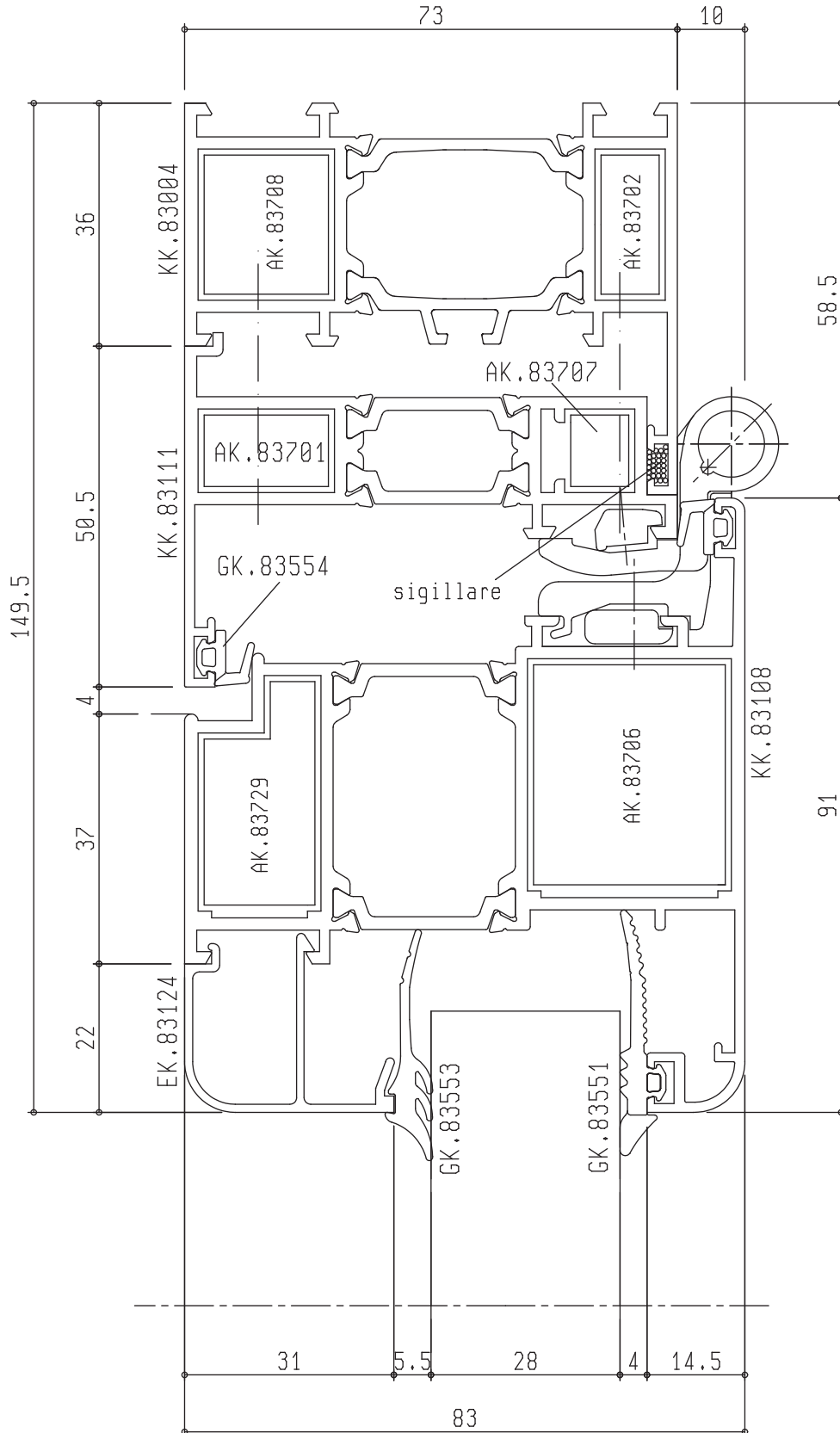

DATA	SCHEDA
Maggio 2016	NS18

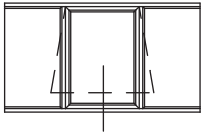

Prospetto
vista esterna

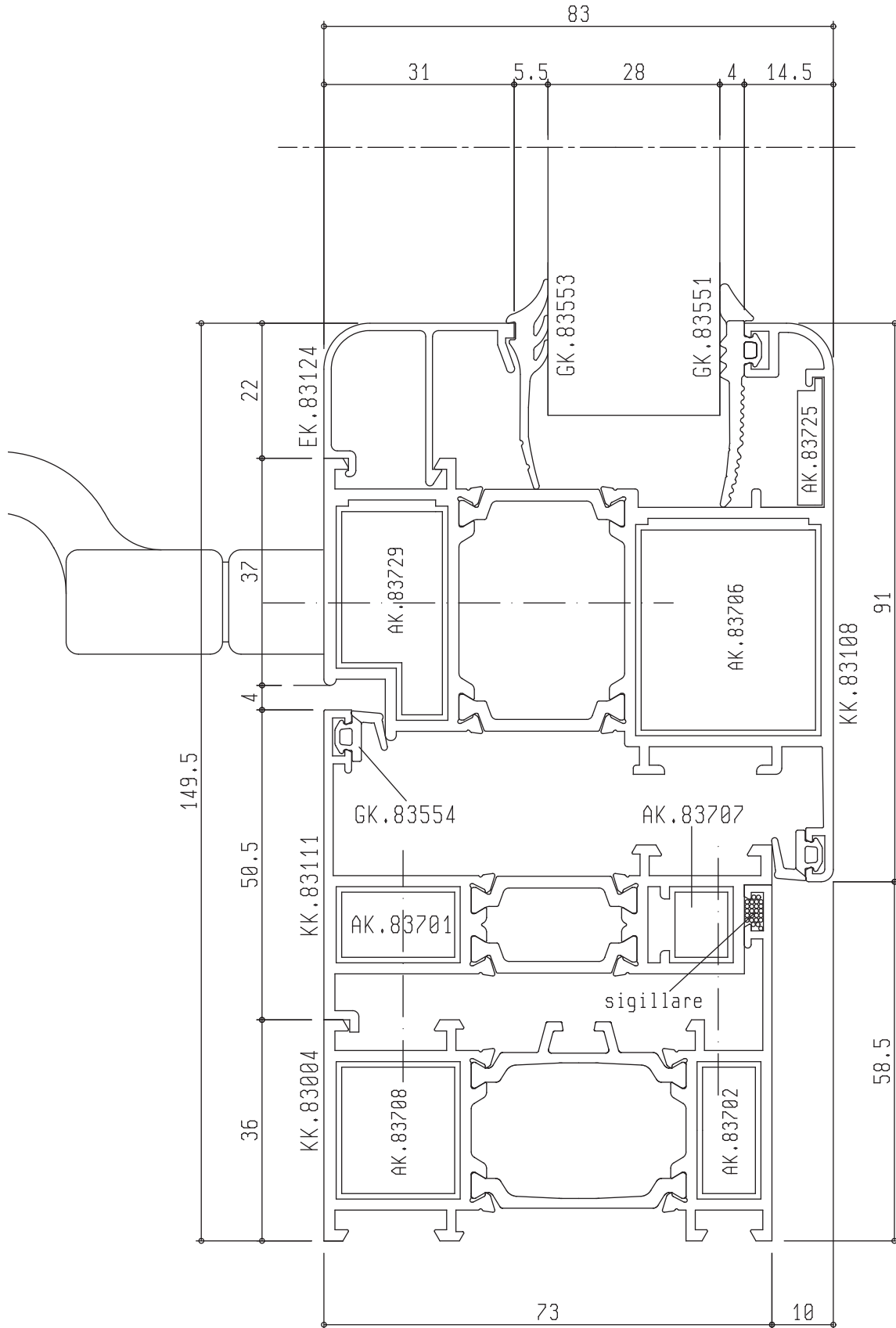

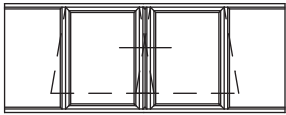

*Prospetto
vista esterna*

SCALA 1:2

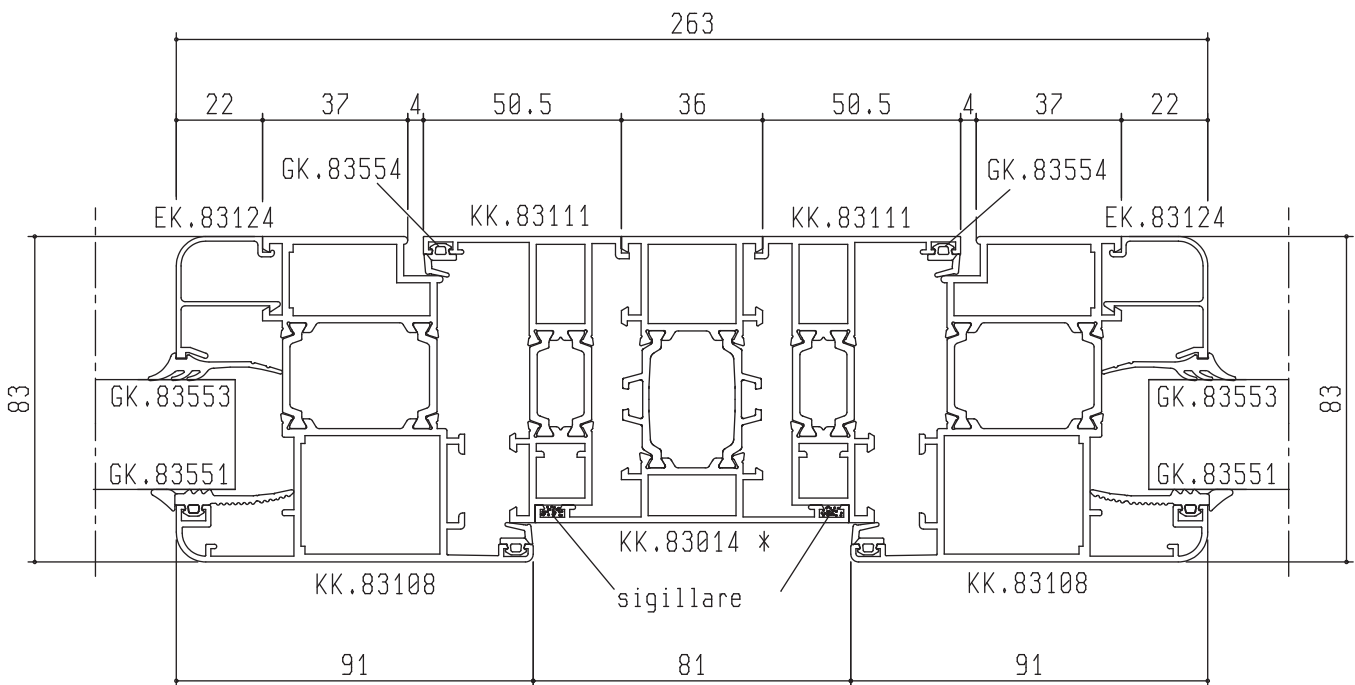

*= USARE SOLO KK.83012 o KK.83014

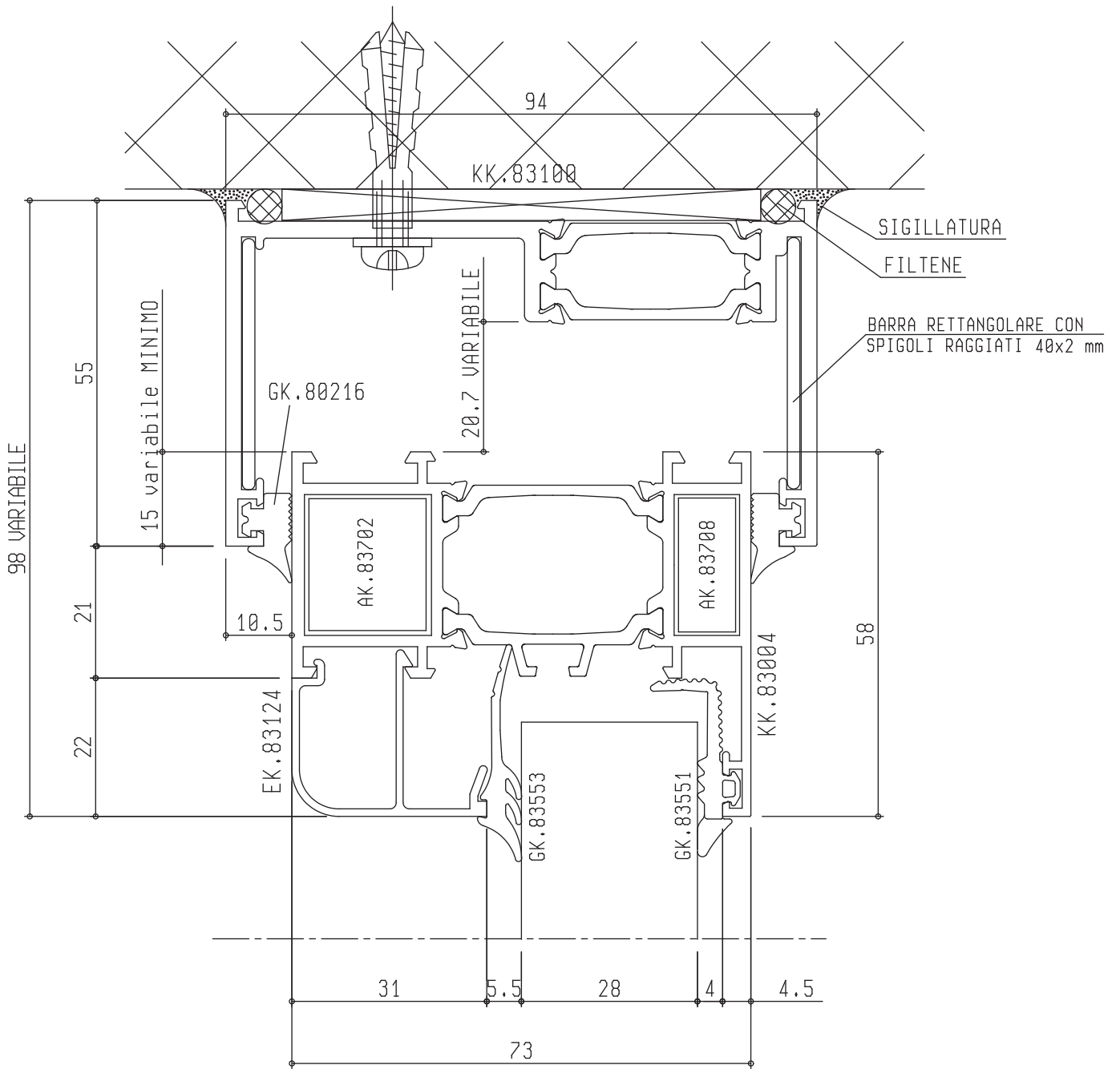

KK.83001

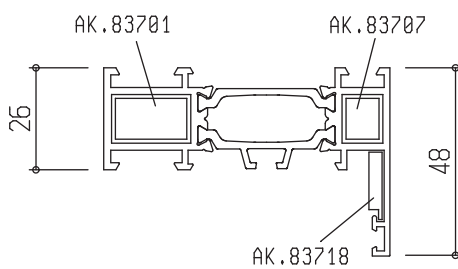

KK.83007

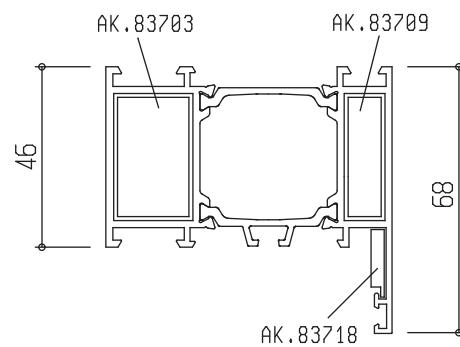

DATA	SCHEDA
Maggio 2016	NSA02

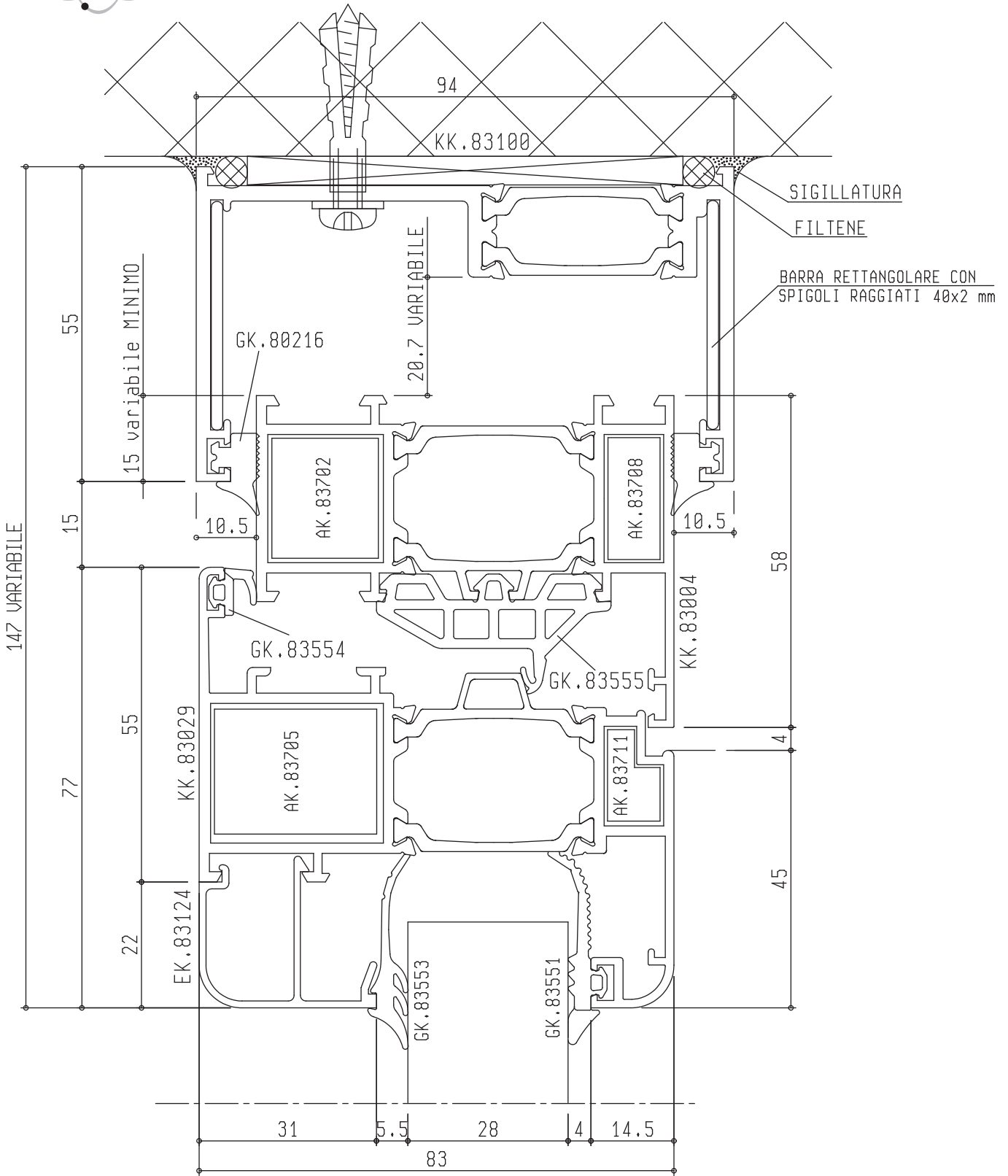

KK.83026

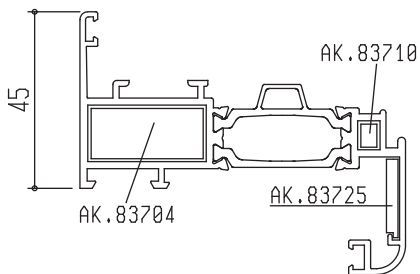

KK.83032

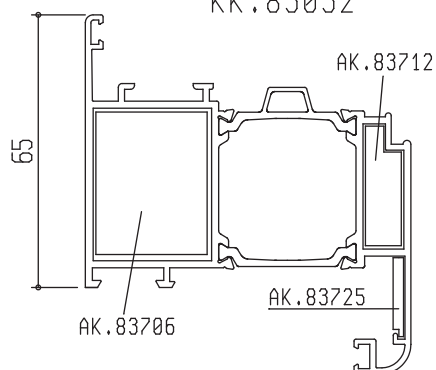

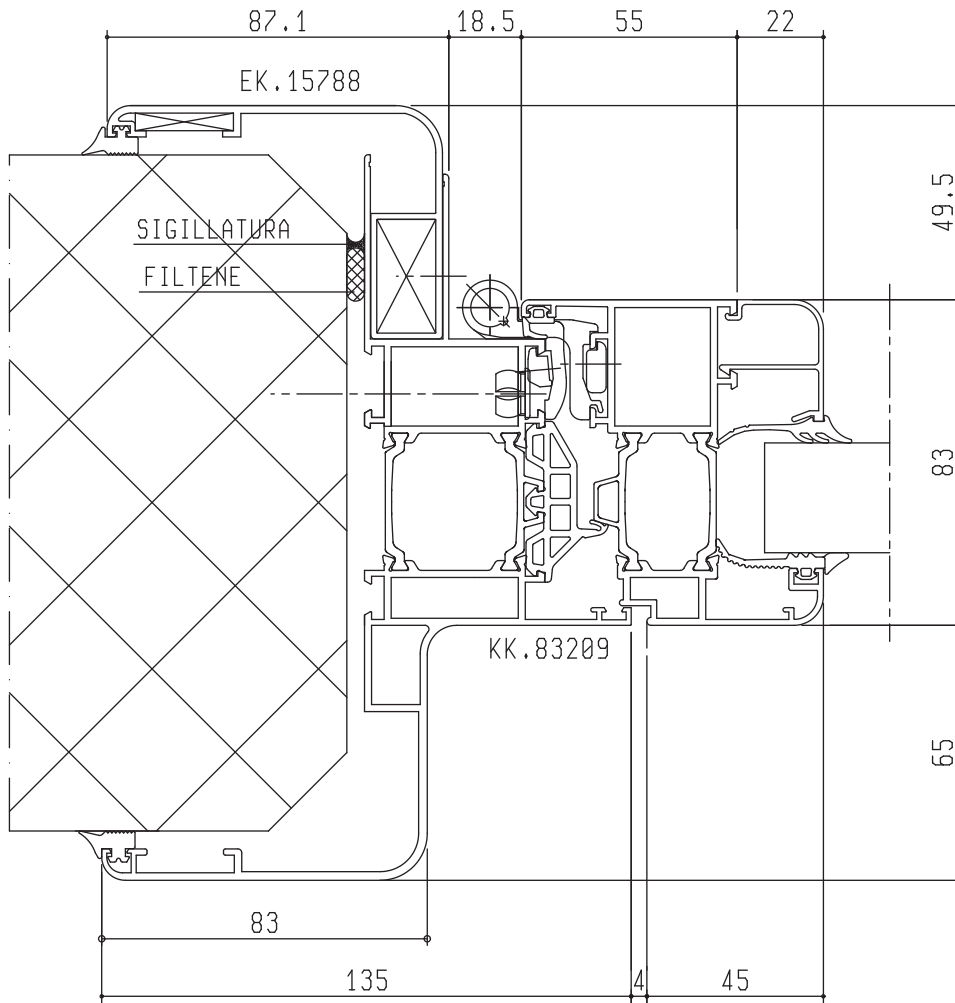

Scala 1:2

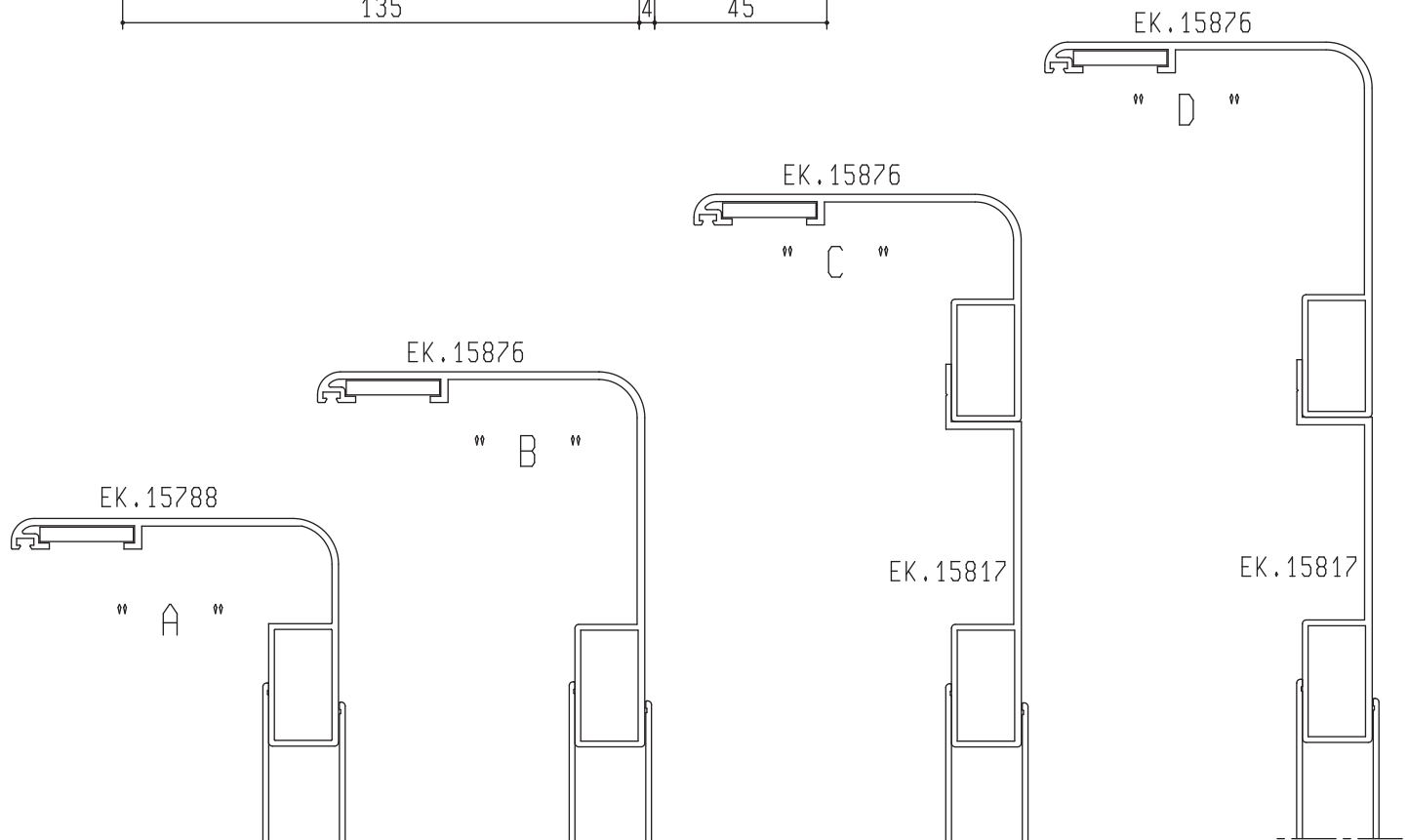

"A" imbotte EK.15788 da 191.5 a 222 mm.

"B" imbotte EK.15876 da 230 a 260 mm.

"C" imbotte EK.15788 + prolunga EK.15817 da 266.5 a 297 mm.

"D" imbotte EK.15876 + prolunga EK.15817 da 305 a 336 mm.

DATA	SCHEDA
Maggio 2016	NSA04

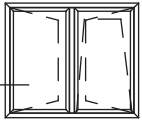

Prospetto
vista esterna

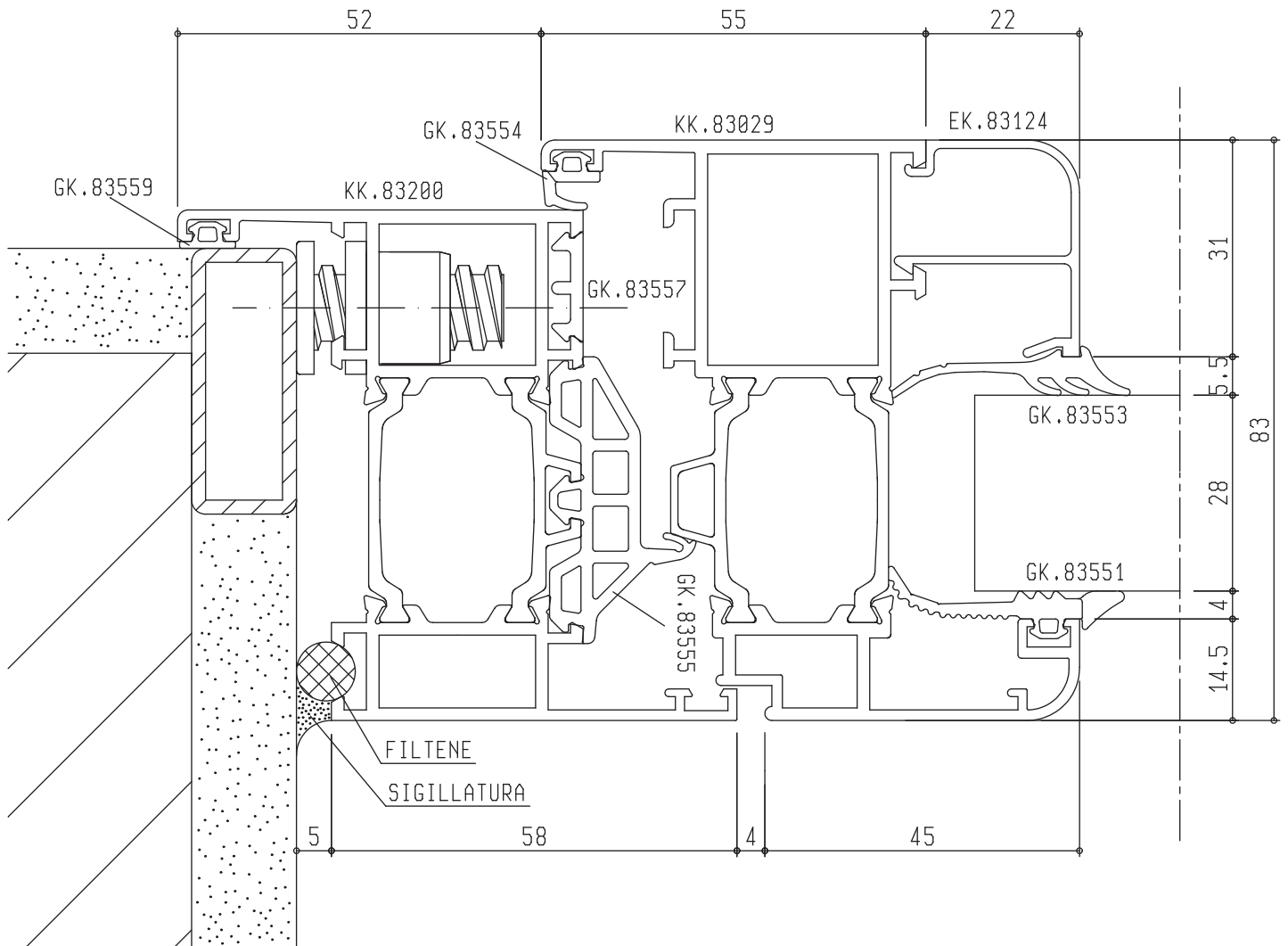

DATA	SCHEDA
Maggio 2016	NSA05

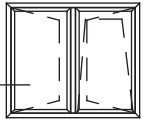

Prospetto
vista esterna

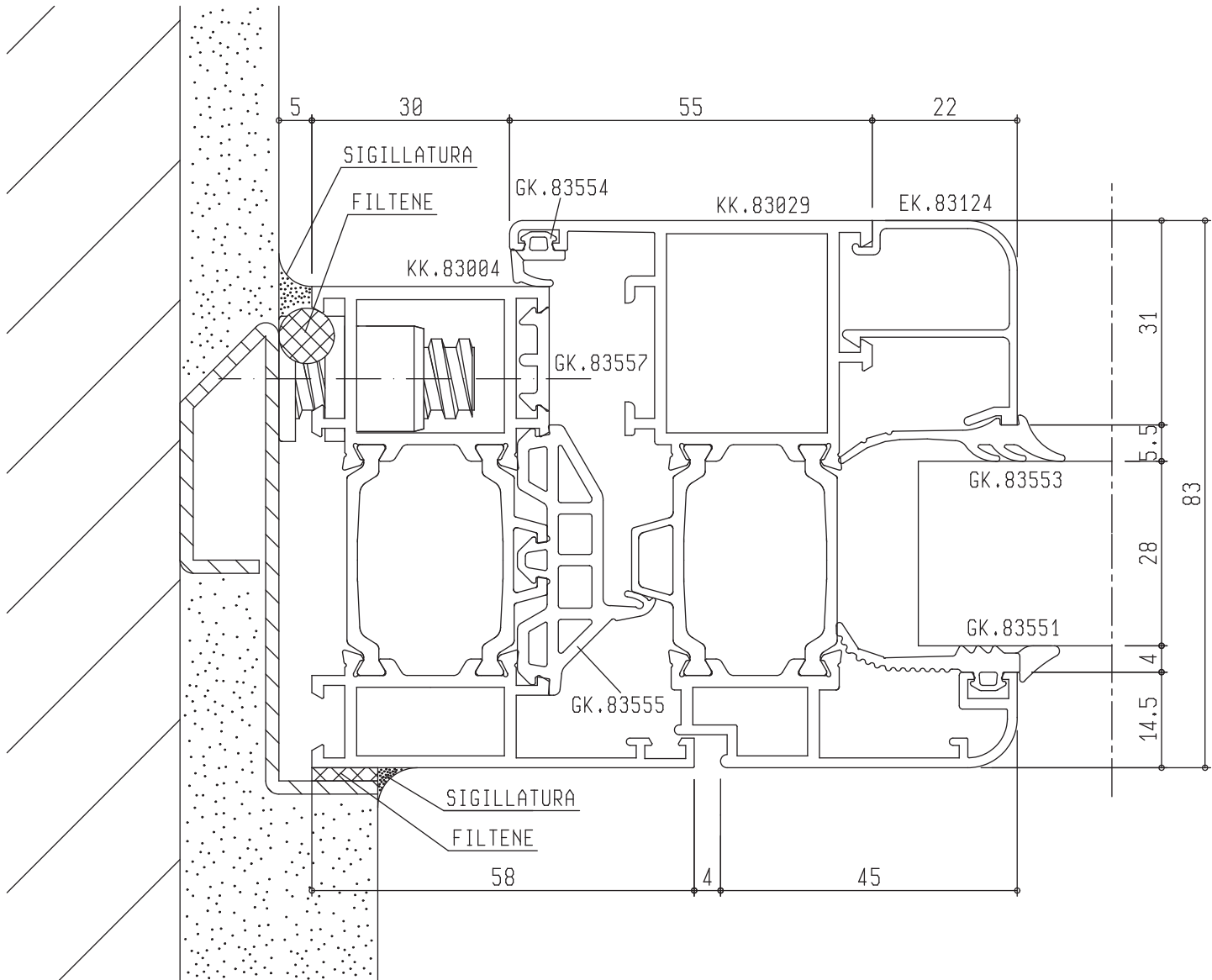

DATA	SCHEDA
Maggio 2016	NSA06

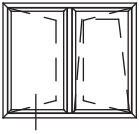

Prospetto
vista esterna

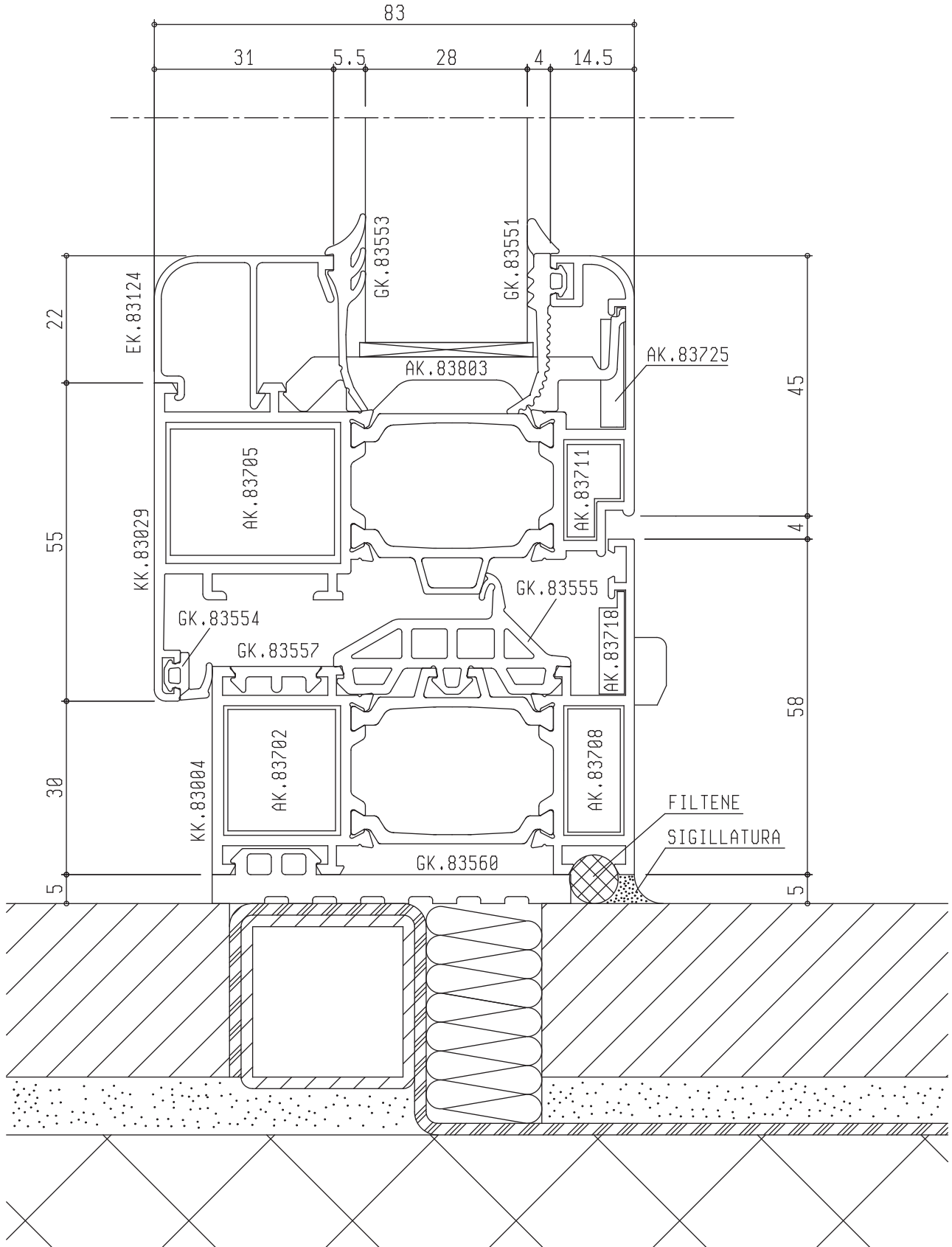

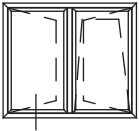

Prospetto
vista esterna

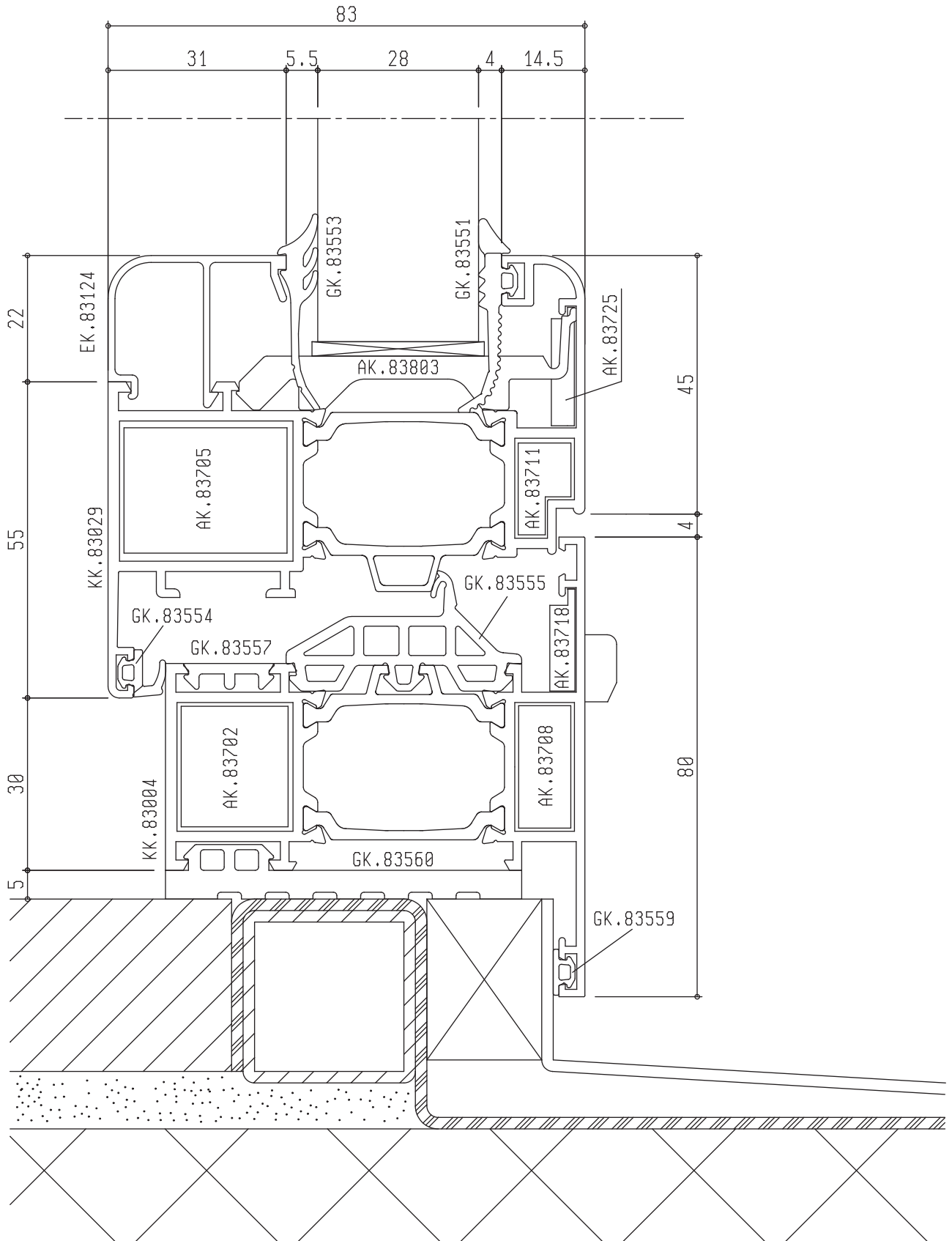

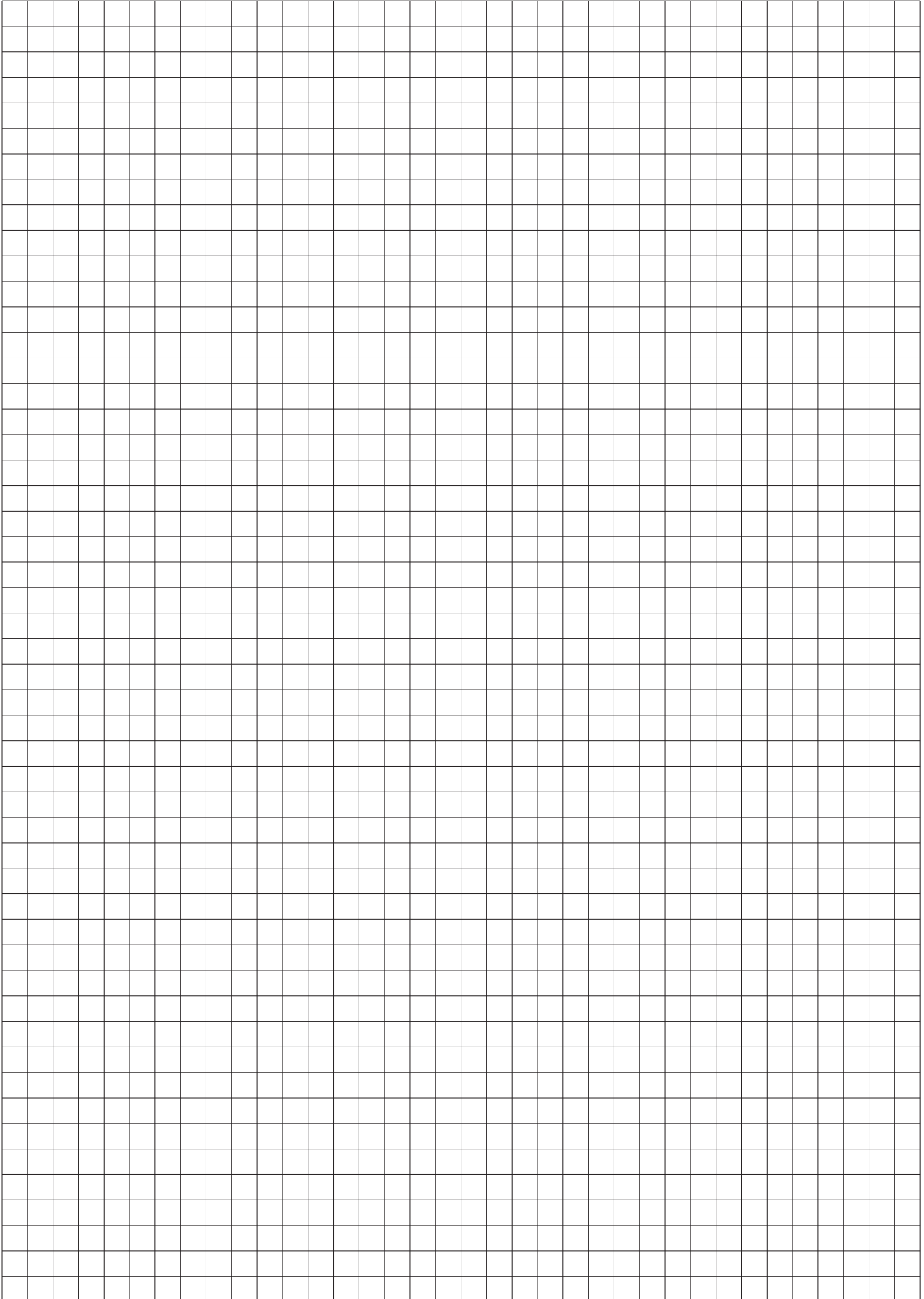

SCHEDE TECNICHE

- *Schede tecniche per il montaggio* (Schede SM)
- *Schede vetrazioni* (Schede SV)
- *Schemi di taglio,
distinte accessori e guarnizioni
per alcune tipologie rappresentative* (Schede ST)

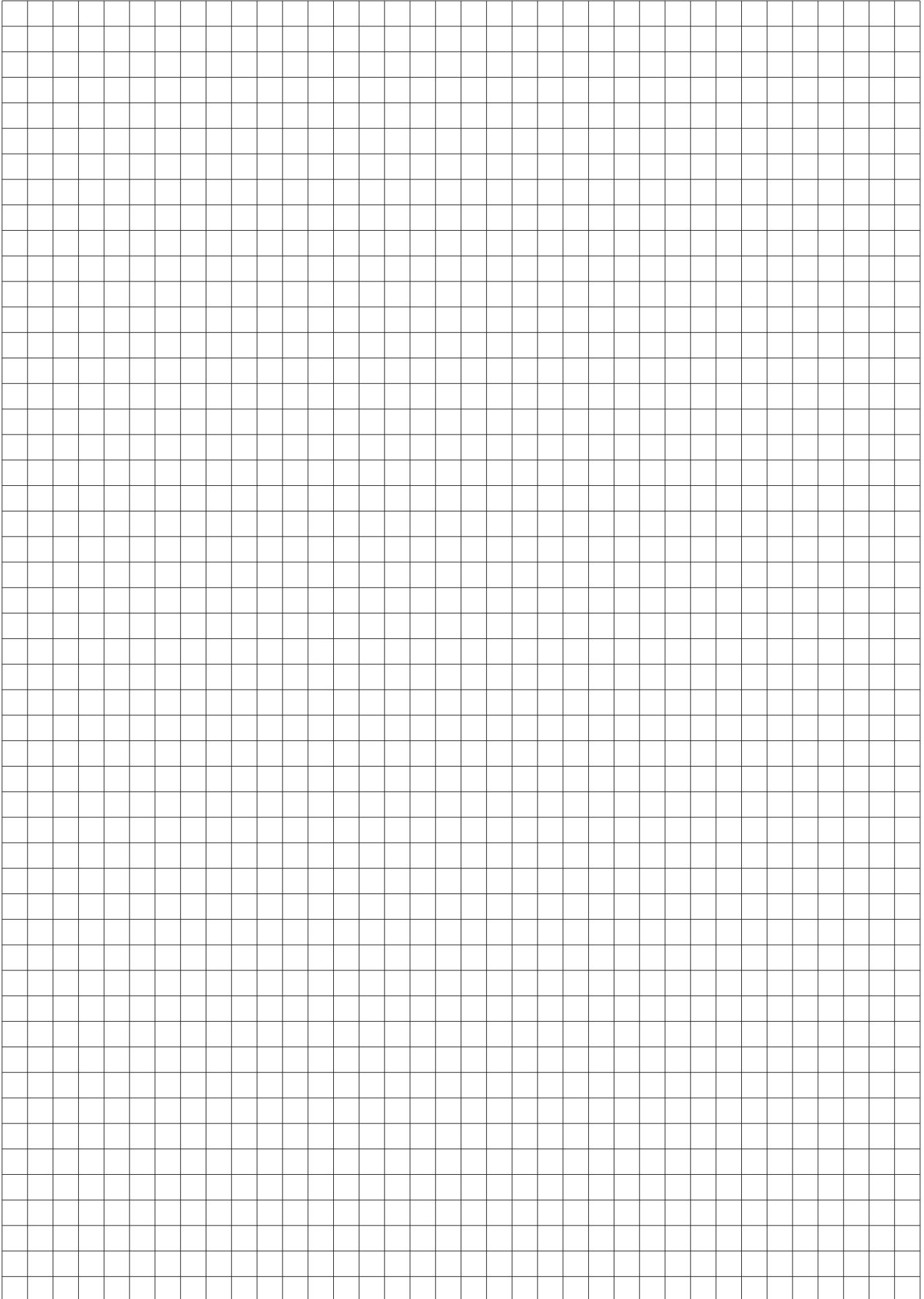

ABACO SQUADRETTE

AK.83701

Squadretta interna

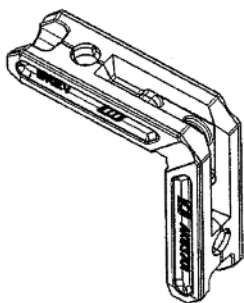

SOLUZIONE PER
TELAJ PICCOLI L-Z-T

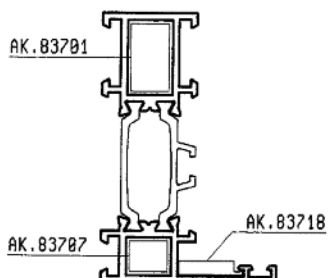

AK.83707

Squadretta esterna

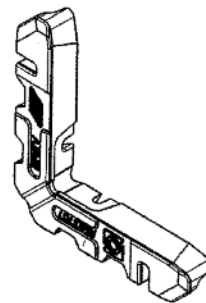

AK.83702

Squadretta interna

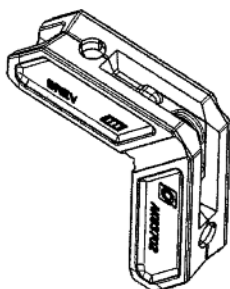

SOLUZIONE PER
TELAJ MEDI L-Z-T

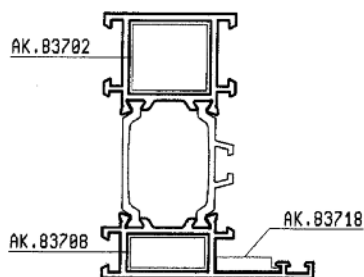

AK.83708

Squadretta esterna

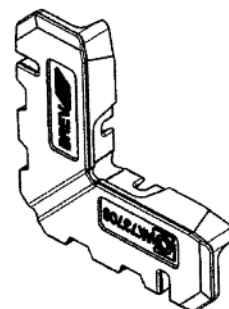

AK.83703

Squadretta interna

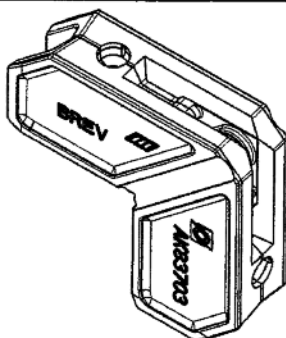

SOLUZIONE PER
TELAJ GRANDI L-Z-T

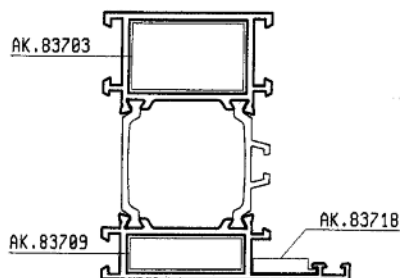

AK.83709

Squadretta esterna

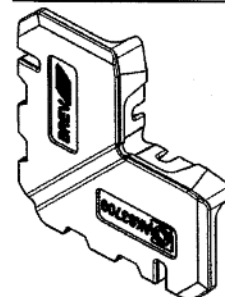

AK.83718

Squadretta di allineamento

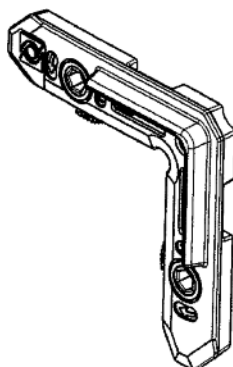

ABACO SQUADRETTE

AK.83704

Squadretta interna

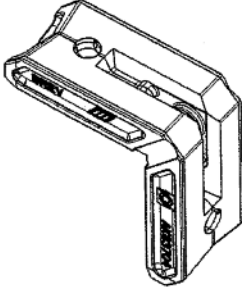

SOLUZIONE PER ANTE PICCOLE Z-T

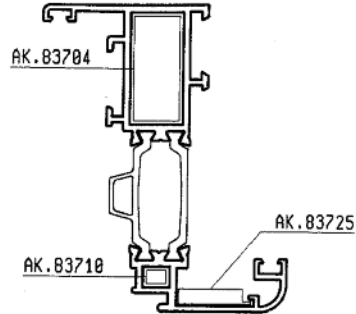

AK.83710

Squadretta esterna

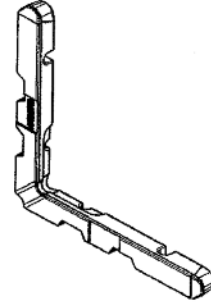

AK.83705

Squadretta interna

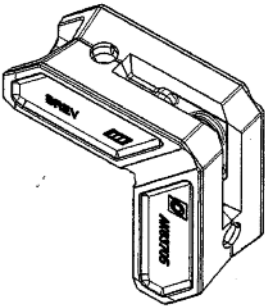

SOLUZIONE PER ANTE MEDIE Z-T

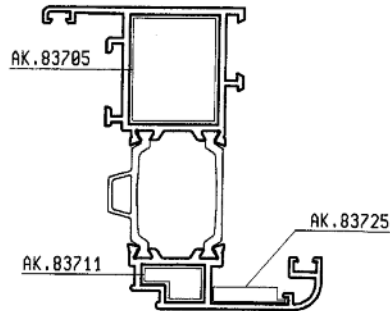

AK.83711

Squadretta esterna

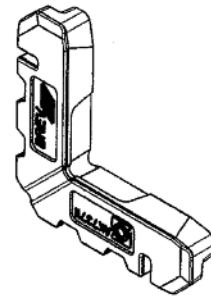

AK.83706

Squadretta interna

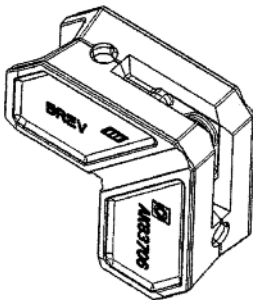

SOLUZIONE PER ANTE GRANDI Z-T

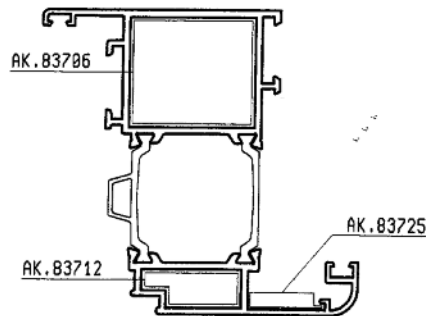

AK.83712

Squadretta esterna

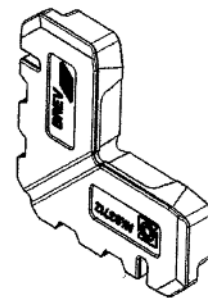

AK.83725

Squadretta di allineamento

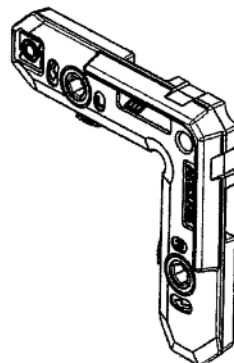

ABACO CAVALLOTTI

Per connessioni con telai fissi
Per connessioni con ante

Per connessioni
con telai fissi

AK.83717
Cavallotto interno

Valido per entrambe le connessioni

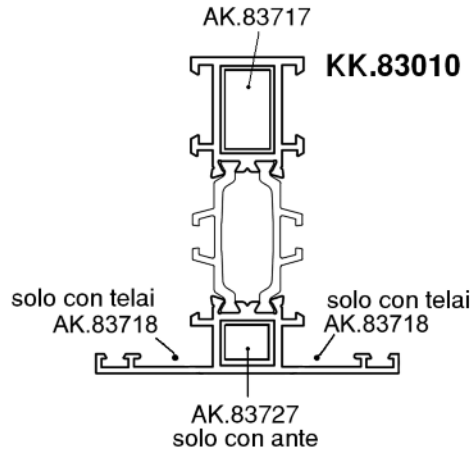
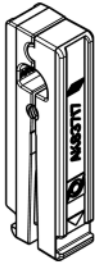

AK.83718
Squadretta allineamento
esterna



Per connessioni con ante

AK.83727
Cavallotto esterno

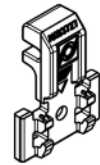

AK.83719
Cavallotto interno

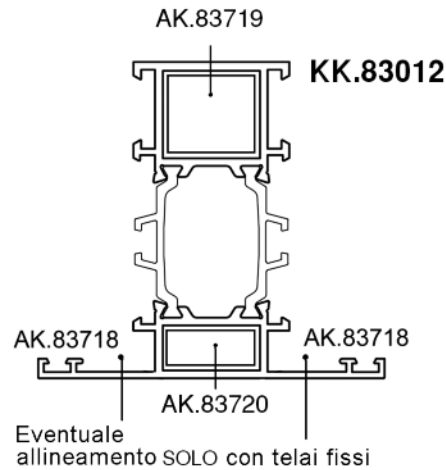
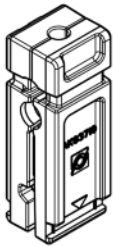

AK.83720
Cavallotto esterno

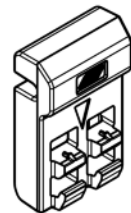

AK.83721
Cavallotto interno

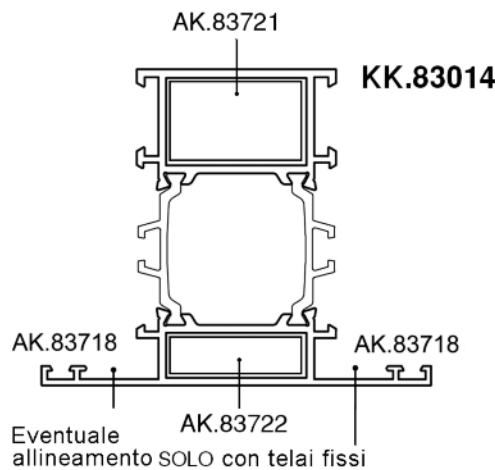

AK.83722
Cavallotto esterno

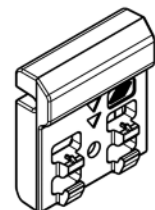

ABACO CAVALLOTTI

Per connessioni sui telai fissi e le ante

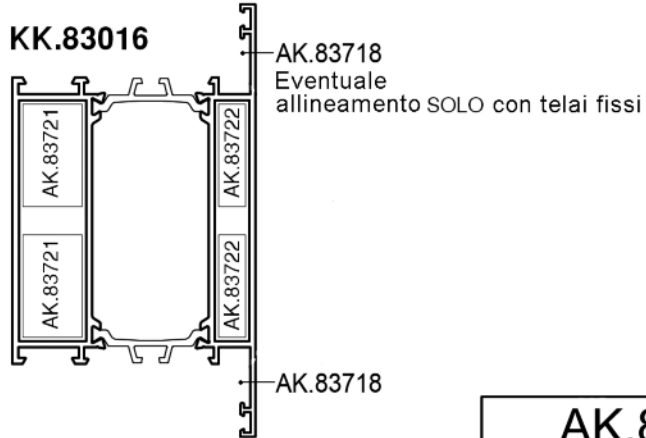

AK.83721
Cavallotto interno

AK.83722
Cavallotto esterno

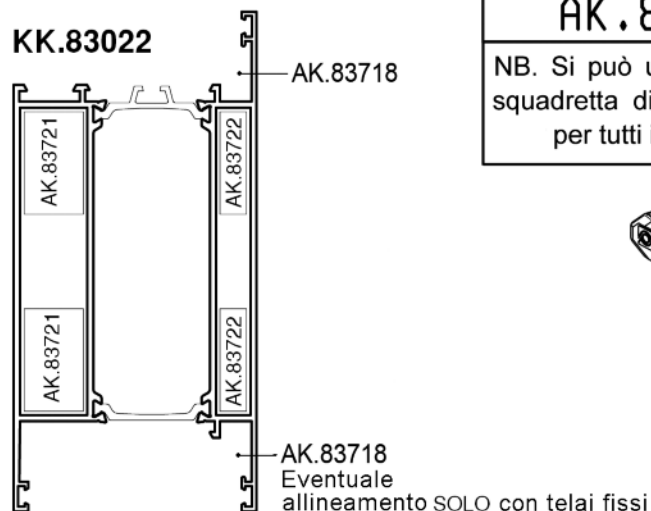
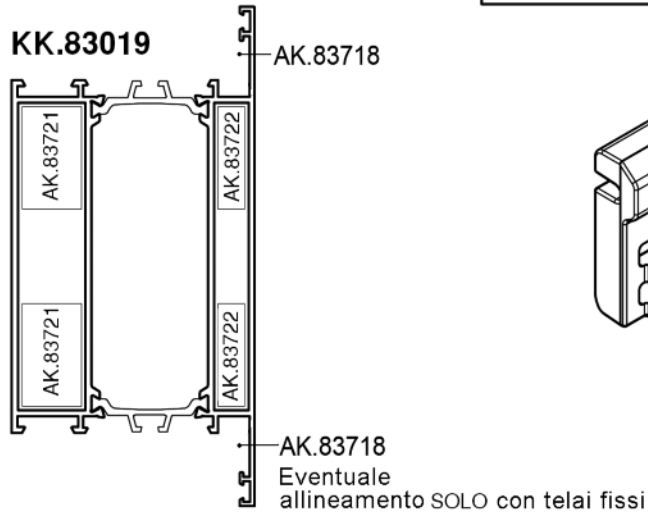
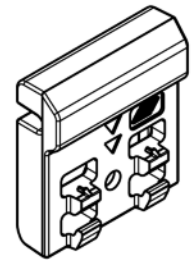

AK.83718
NB. Si può utilizzare come squadretta di allineamento per tutti i telai fissi.

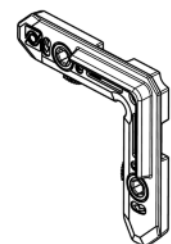

ABACO SQUADRETTE

Per finestre a sporgere

AK.83729

Squadretta interna

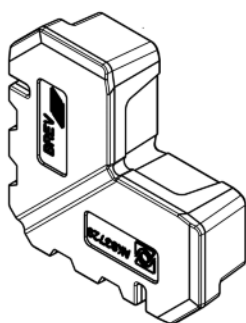

AK.83706

Squadretta esterna

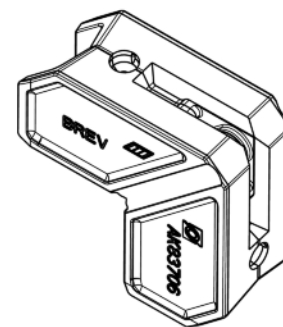

KK.83108

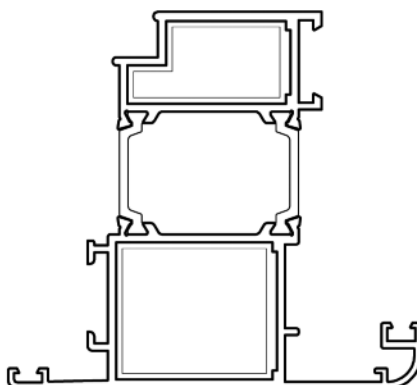

AK.83701

Squadretta interna



AK.83707

Squadretta esterna

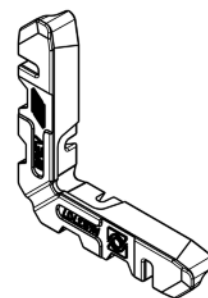

KK.83111

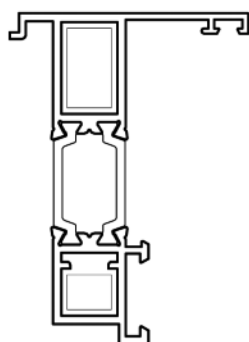

SCHEMA PER UTILIZZO GUARNIZIONI

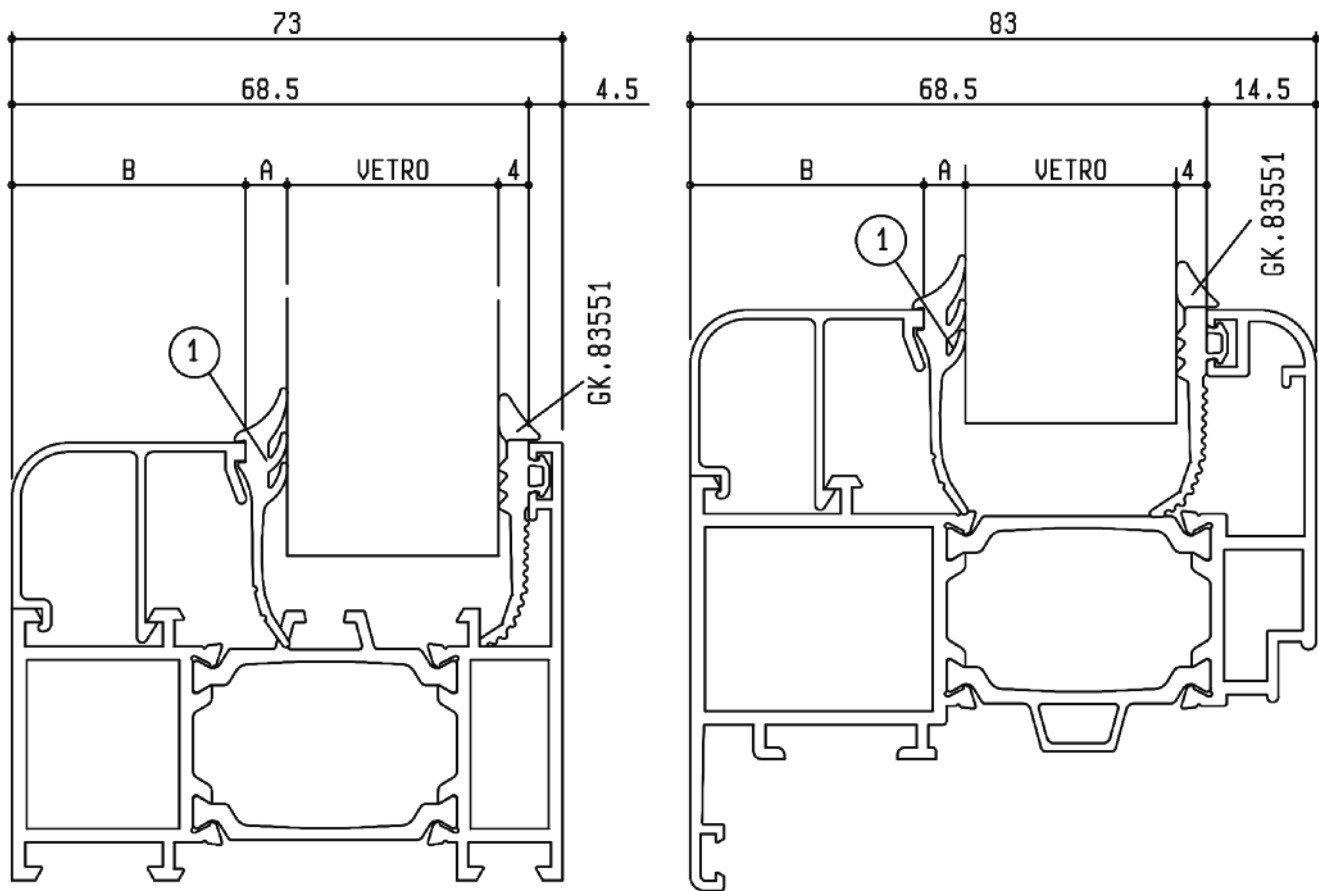

VETRO	GUARNIZIONE ①		FERMAVETRO	
	A	CODICE	B	CODICE
24 mm	5,5	GK.83553	35	EK.83128
26 mm	3,5	GK.83552	35	EK.83128
28 mm	5,5	GK.83553	31	EK.83124
30 mm	3,5	GK.83552	31	EK.83124
32 mm	5,5	GK.83553	27	EK.16102
34 mm	3,5	GK.83552	27	EK.16102
36 mm	5,5	GK.83553	23	EK.13086
38 mm	3,5	GK.83552	23	EK.13086

TABELLA PER SPESSORAMENTO VETRI

■ Spessori portanti
□ Spessori distanziatori

Telaio fisso

Anta battente

Anta ribalta

Wasistas

Sporgere

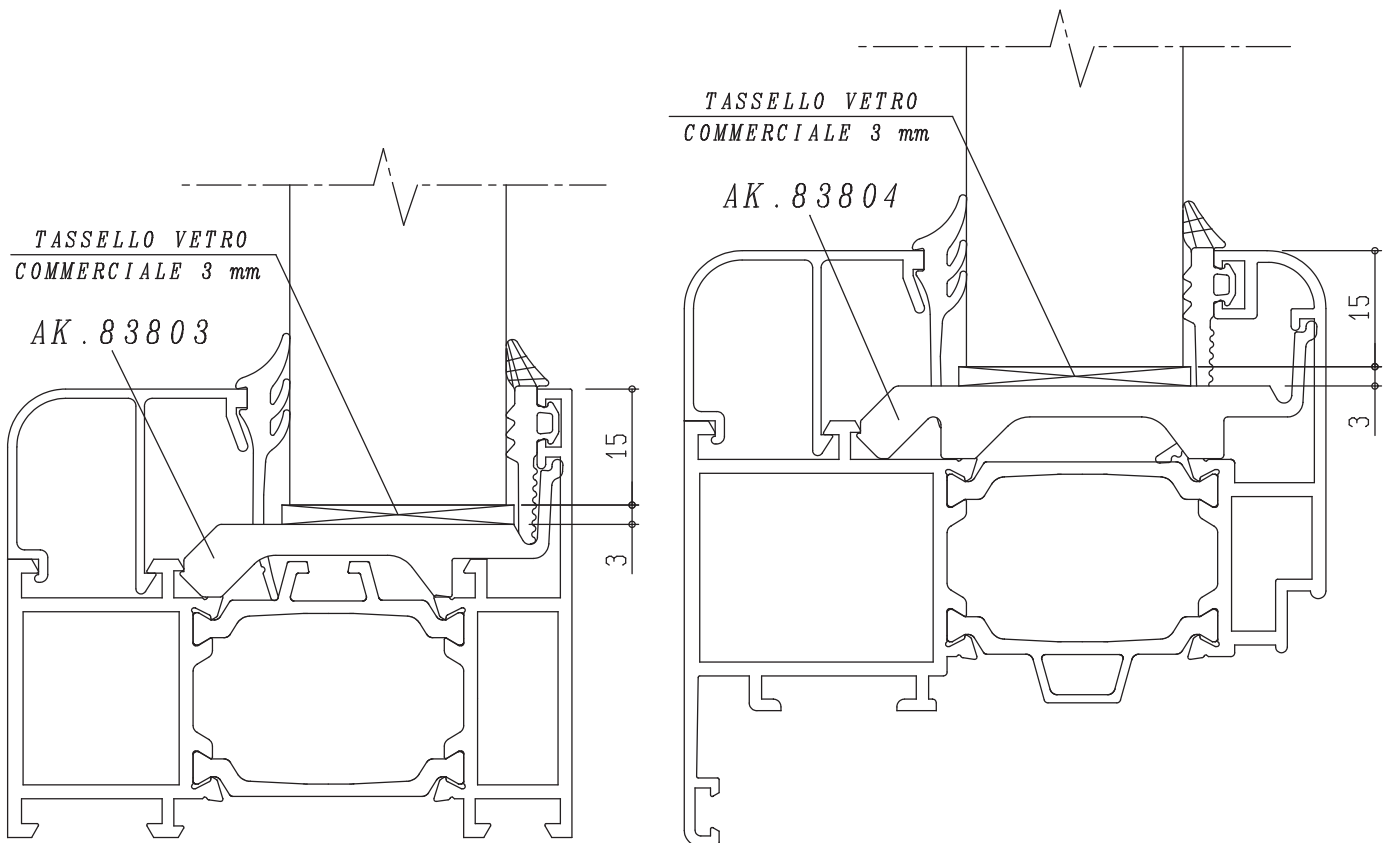
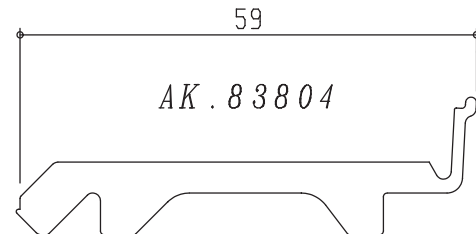
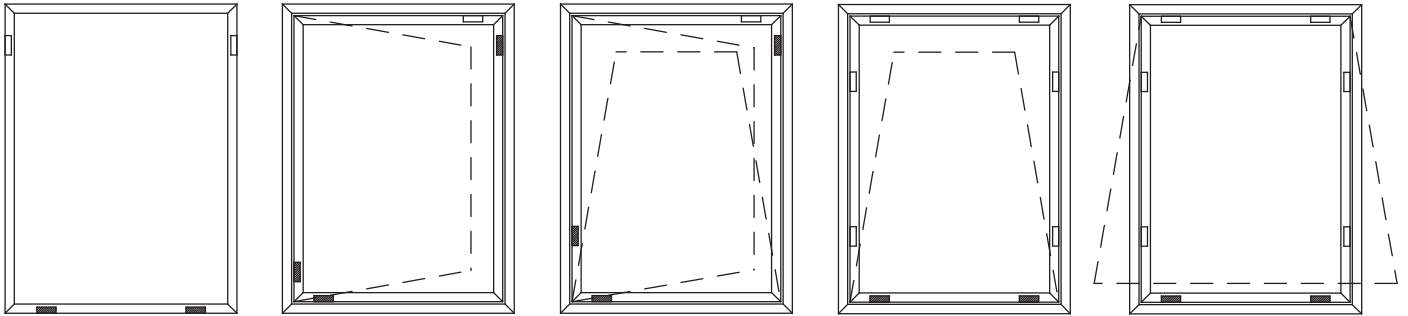

Il posizionamento ed il numero dei tasselli sono ricavati dal manuale "UX 42 - GUIDA ALLA CORRETTA POSA IN OPERA" dell'UNCSAAL.

Per ulteriori dettagli farvi riferimento.

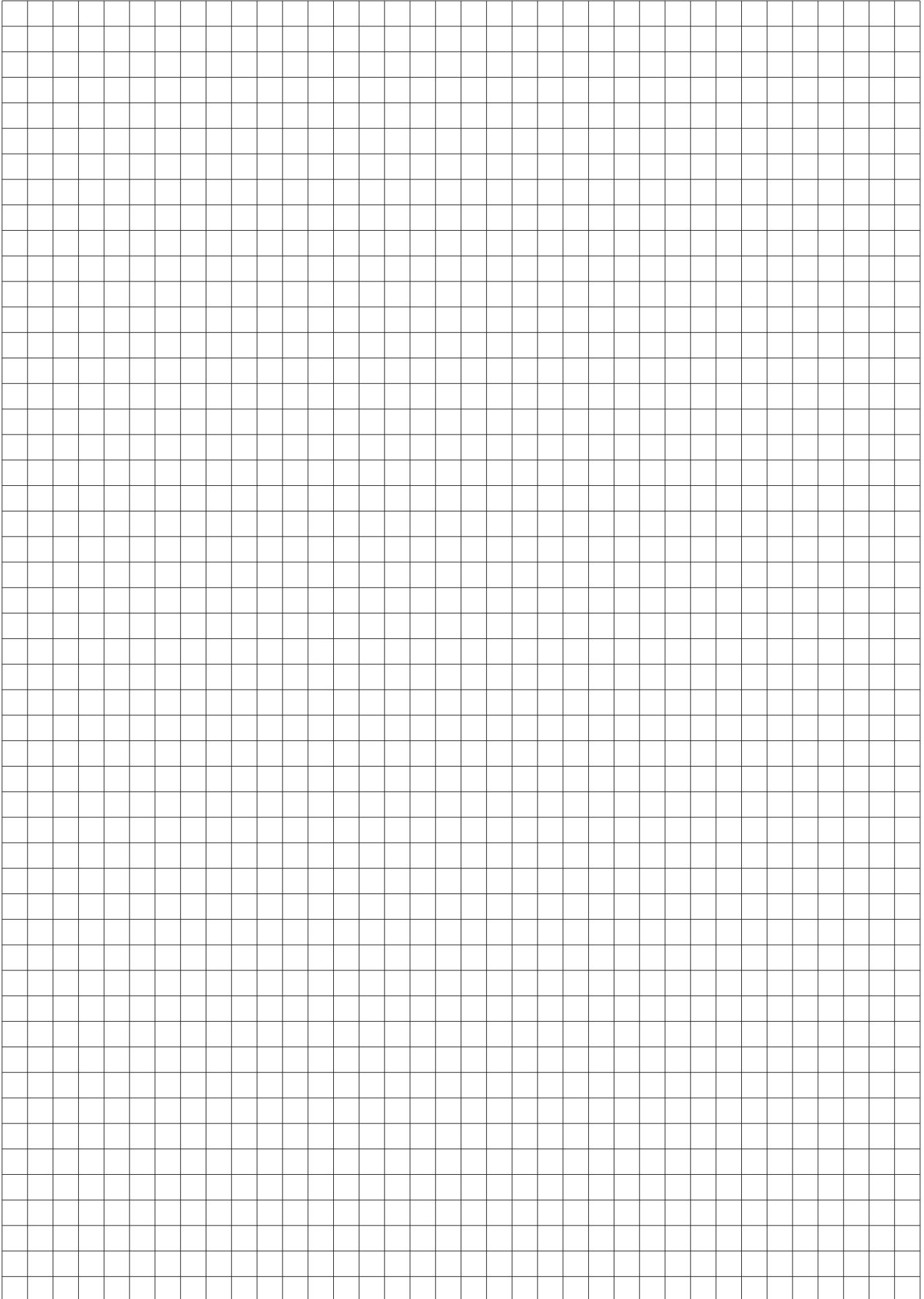

*ABACO DISTINTE DI TAGLIO
DELLE TIPOLOGIE PIU' RAPPRESENTATIVE*

FINESTRE

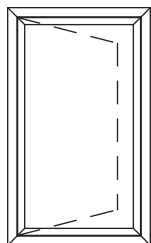

*SCHEDA
ST01*

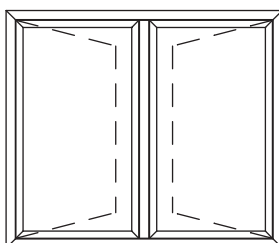

*SCHEDA
ST02
con battuta centrale riportata*

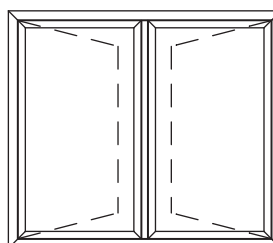

*SCHEDA
ST03
con "t-z"*

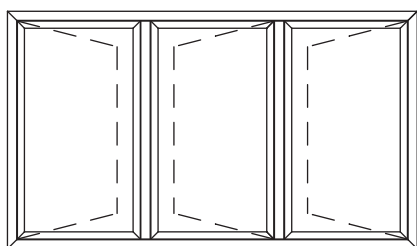

*SCHEDA
ST04
con battuta centrale riportata*

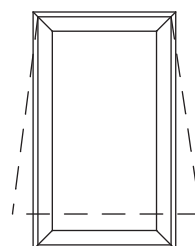

*SCHEDA
ST07*

PORTE FINESTRE

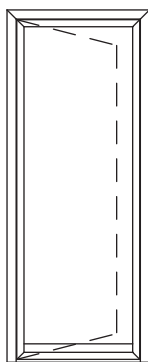

*SCHEDA
ST05
Soluzione a giunto aperto
con soglia ribassata*

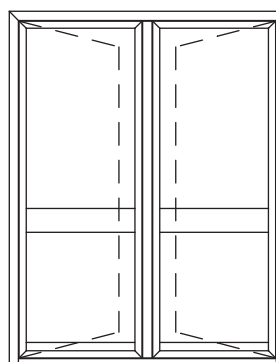

*SCHEDA
ST06
Soluzione standard*

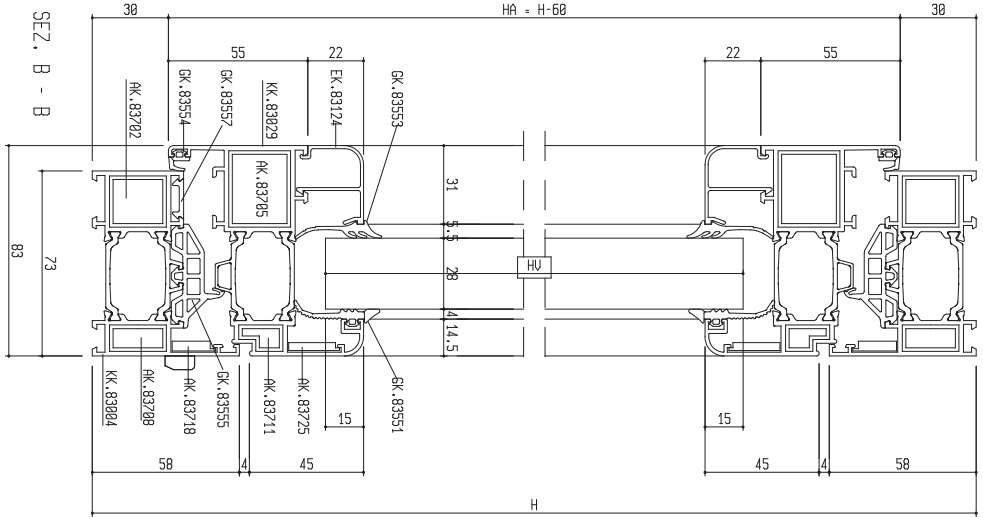

Prospetto visto dall'esterno

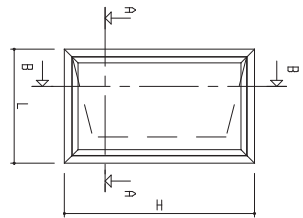

Peso indicativo ALLUMINIO
 $L \dots \times 7,210 = Kg \dots +$
 $H \dots \times 7,210 = Kg \dots +$
 Peso totale = kg.

PROFILATI	CODICE	PEZZI	MISURE	TAGLIO
Traverso telaio "L"	KK.83004	2	L	45-45
Montante telaio "L"	KK.83004	2	H	45-45
Traverso anta "Z"	KK.83029	2	L-60	45-45
Montante anta "Z"	KK.83029	2	H-60	45-45
Fermavetro	EK.83124	2	L-214	90-90
Fermavetro	EK.83124	2	H-214	90-90
Astina	ZK.09528			

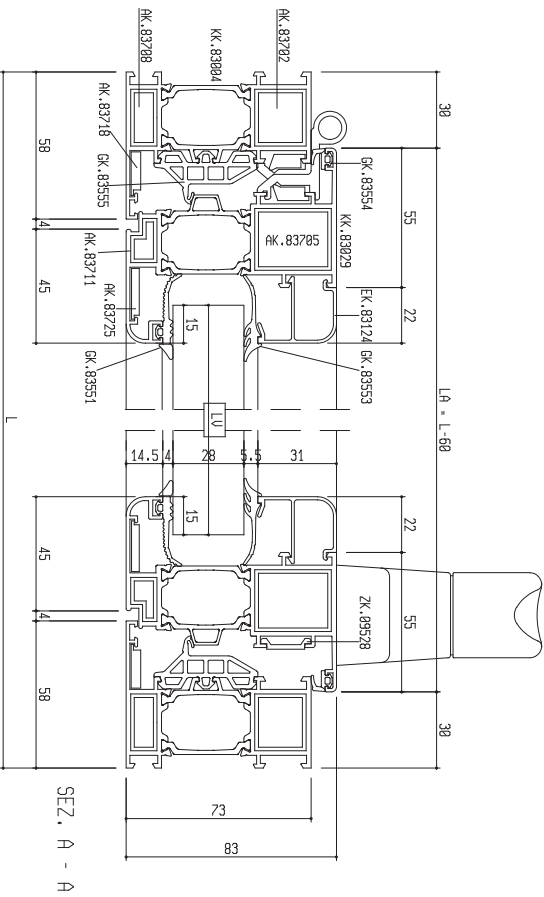

SUPPLIMENTI

DESCRIZIONE	CODICE	PEZZI
Battuta interna	GK.83554	2H+2L
Battuta centrale	GK.83555	2H+2L
Cingivetro esterna	GK.83551	2H+2L
Cingivetro interna	GK.83553	2H+2L
Guarnizione filo camera	GK.83557	L

ACCESSORI PERSONALIZZATI

DESCRIZIONE	CODICE	PEZZI
Squadretta interna telaio	GK.83702	4
Squadretta interna anta	GK.83705	4
Squadretta esterna telaio	GK.83708	4
Squadretta esterna anta	GK.83711	4
Squadretta allineamento telaio	GK.83718	4
Squadretta allineamento anta	GK.83725	4
Angolo pressofuso fermavetro	GK.93559	4
Spessore vetro	GK.83804	4
Angolo preformato	GK.83556	4
Regolo distanziatore	GK.93813	4

ACCESSORI COMMERCIALI

ACCESSORI COMMERCIALI A CAMERA EUROPEA DI FORNITORI QUALIFICATI

DISTINTA VETRI	PEZZI	MISURE L x H
Vetro	1	(L=LA-124) x (H=HA-124)

GUARNIZIONI	CODICE	PEZZI
Battuta interna	GK.83554	3H+2L
Battuta centrale	GK.83555	3H+2L
Cingivetro esterna	GK.83551	4H+2L
Cingivetro interna	GK.83553	4H+2L
Guarnizione filo camera	GK.83557	L
ACCESSORI PERSONALIZZATI	CODICE	PEZZI
Squadretta interna telaio	AK.83702	4
Squadretta interna anta	AK.83705	8
Squadretta esterna telaio	AK.83708	4
Squadretta esterna anta	AK.83711	8
Squadretta allineamento telaio	AK.83718	4
Squadretta allineamento anta	AK.83725	8
Angolo pressofuso fermavetro	AK.93559	8
*Coppia tappi battuta centrale	AK.83814R	1
Spessore vetro	AK.83804	8
Angolo preformato	GK.83556	4
Regolo distanziatore	AK.93813	in base alle dimensioni

PROFILATI	CODICE	PEZZI	MISURE	TAGLIO
Traverso telaio "L"	KK.83004	2	L	45-45
Montante telaio "L"	KK.83004	2	H	45-45
Traverso anta "Z"	KK.83029	4	(L-63.5)/2	45-45
Montante anta "Z"	KK.83029	4	H-60	45-45
* Battuta centrale riportata	KK.83035	1	H-130	90-90 * (H-132)
Fermavetro	EK.83124	4	LA-154	90-90
Fermavetro	EK.83124	4	H-214	90-90
Astina	ZK.89528	4	H-214	90-90

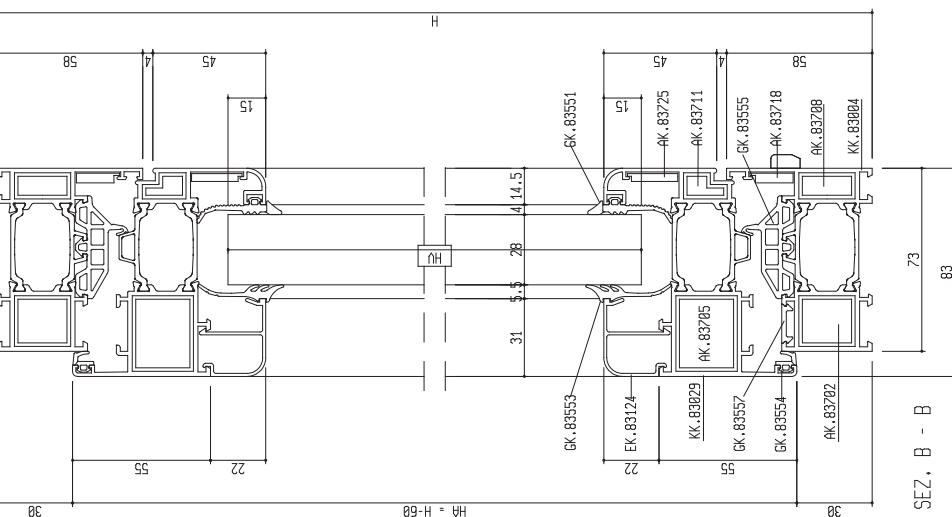

ACCESSORI COMMERCIALI	CODICE	PEZZI
SOLUZIONE ALTERNATIVA CON TAPPI	AK.83814M (H-132)	MISURE TAGLIO 90-90

ACCESSORI COMMERCIALI A CAMERA EUROPEA DI FORNITORI QUALIFICATI	CODICE	PEZZI	MISURE L x H
Vetro 1		1	(LV1=LA-124) x (HU=HA-124)
Vetro 2		1	(LV2=LA-124) x (HU=HA-124)

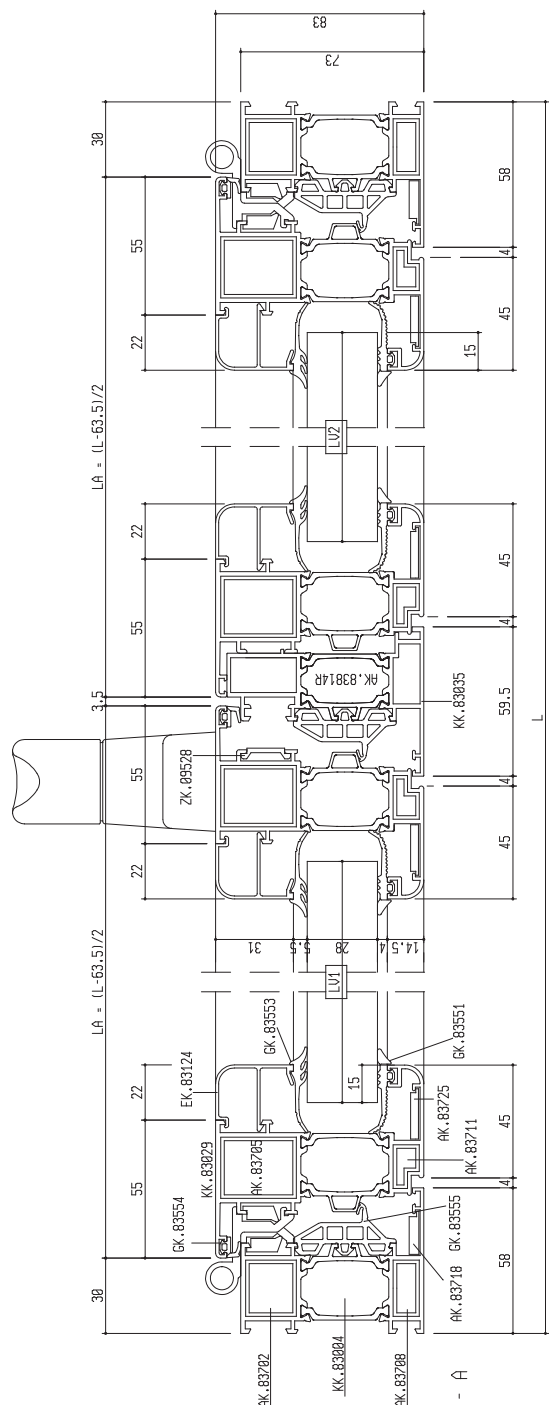

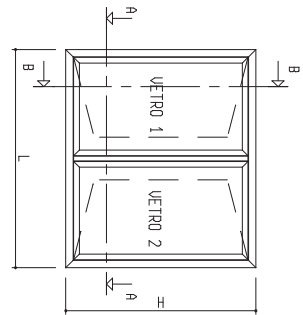
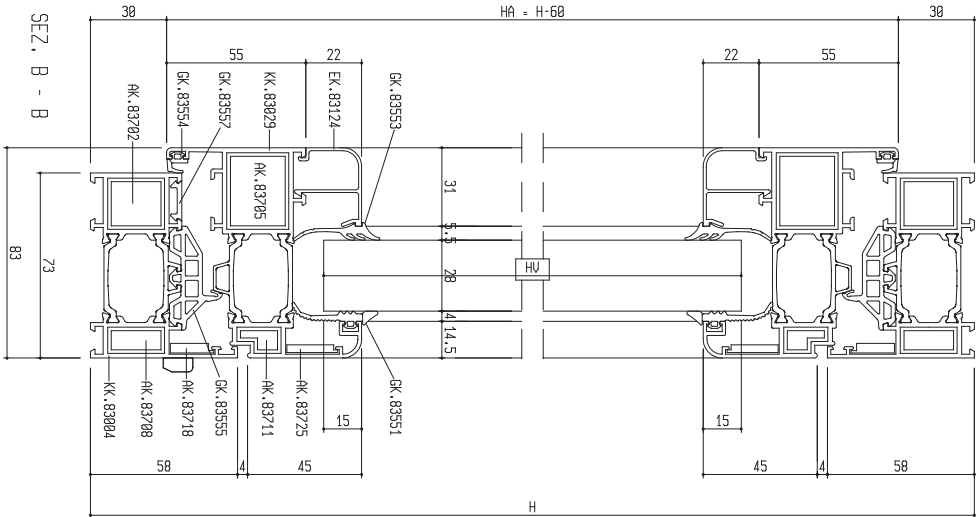

Prospetto visto dall'esterno

Peso indicativo ALLUMINIO

L..... x 7.210 = Kg..... +
H..... x 11.557 = Kg..... +
Peso totale = Kg.....

PROFILATI	CODICE	PEZZI	MISURE	TAGLIO
Traverso telaio "L"	KK.83004	2	L	45-45
Montante telaio "L"	KK.83004	2	H	45-45
Traverso anta "Z"	KK.83029	4	L/2-21	45-45
Montante anta "Z"	KK.83029	3	H-60	45-45
Montante anta "T"	KK.83040	1	H-41	45-45
Fermavetro	EK.83124	4	LH-154	90-90
Fermavetro	EK.83124	4	H-214	90-90
Astina	ZK.09528			

SEZ. A - A

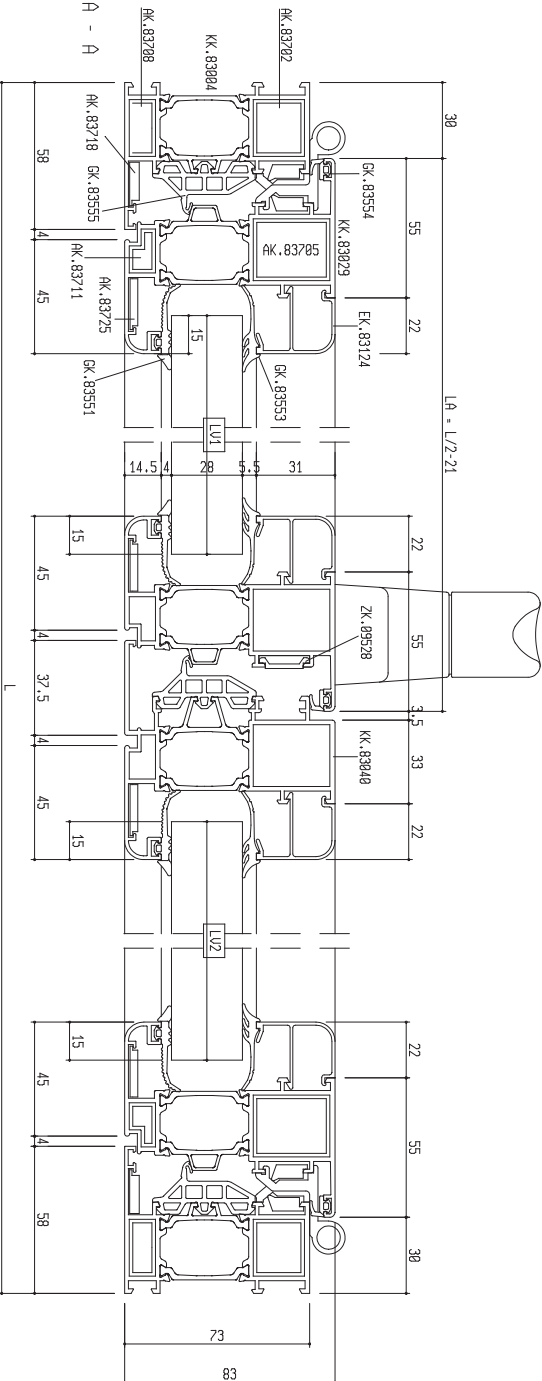

GUARNIZIONI

GUARNIZIONI	CODICE	PEZZI
Battuta interna	GK.83554	3H+2L
Battuta centrale	GK.83555	3H+2L
Cingivetro esterna	GK.83551	4H+2L
Cingivetro interna	GK.83553	4H+2L
Guarnizione filo camera	GK.83557	L
ACCESSORI PERSONALIZZATI	CODICE	PEZZI

Squadrella interna telaio	AK.83702	4
Squadrella interna anta	AK.83705	8
Squadrella esterna telaio	AK.83708	4
Squadrella esterna anta	AK.83711	8
Squadrella allineamento telaio	AK.83718	4
Squadrella allineamento anta	AK.83725	8
Angolo pressofuso fermavetro	AK.93559	8
Kit tappi battuta centrale T/Z	AK.83813	1
Spessore vetro	AK.83804	8
Angolo preformato	GK.83556	8
Regolo distanziatore	AK.93813	4
ACCESSORI COMMERCIALI	CODICE	PEZZI

ACCESSORI COMMERCIALI A CAMERA EUROPEA DI FORNITORI QUALIFICATI

DISTINTA VETRI	PEZZI	MISURE L x H
Vetro 1	1	(LUV=LH-124) x (HV=HA-124)
Vetro 2	1	(LUV=LH-124) x (HV=HA-124)

Prospetto visto dall'esterno

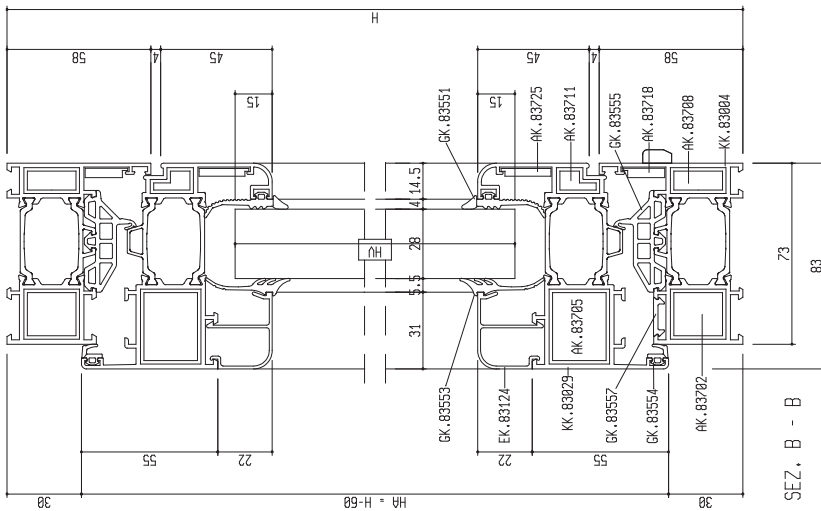

Peso indicativo ALLUMINIO

L..... x 7.210 = Kg..... +
H..... x 18.398 = Kg..... +
Peso totale = Kg.....

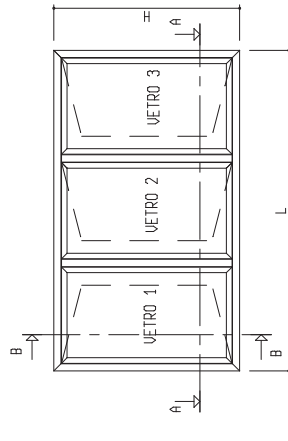

GUARNIZIONI	CODICE	PEZZI
Battuta interna	GK.83554	4H+2L
Battuta centrale	GK.83555	4H+2L
Cingivetro esterna	GK.83551	6H+2L
Cingivetro interna	GK.83553	6H+2L
Guarnizione filo camera	GK.83557	L
ACCESSORI PERSONALIZZATI	CODICE	PEZZI
Squadretta interna telaio	AK.83702	4
Squadretta interna anta	AK.83705	12
Squadretta esterna telaio	AK.83708	4
Squadretta esterna anta	AK.83711	12
Squadretta allineamento telaio	AK.83718	4
Squadretta allineamento anta	AK.83725	12
Angolo pressofuso fermavetro	AK.93559	12
* Coppia tappi battuta centrale	AK.83814R	2 *
Spessore vetro	AK.83804	12
Angolo preformato	GK.83556	4
Regolo distanziatore	AK.93813	in base alle dimensioni

* SOLUZIONE ALTERNATIVA CON TAPPI AK.83814M

PROFILATI	CODICE	PEZZI	MISURE	TAGLIO
Traverso telaio "L"	KK.83004	2	L	45-45
Montante telaio "L"	KK.83004	2	H	45-45
Traverso anta "Z"	KK.83029	6	(L-67)/3	45-45
Montante anta "Z"	KK.83029	6	H-68	45-45
* Battuta centrale riportata	KK.83035	2	H-130	90-90 * (H-132)
Fermavetro	EK.83124	6	LA-154	90-90
Fermavetro	EK.83124	6	H-214	90-90
Astina	ZK.09528			

* SOLUZIONE ALTERNATIVA CON TAPPI AK.83814M (H-132) MISURE TAGLIO 90-90 *

DISTINTA VETRI	PEZZI	MISURE L x H
Vetro 1	1	(LV1=LA-124) x (HV=HA-124)
Vetro 2	1	(LV2=LA-124) x (HV=HA-124)
Vetro 3	1	(LV3=LA-124) x (HV=HA-124)

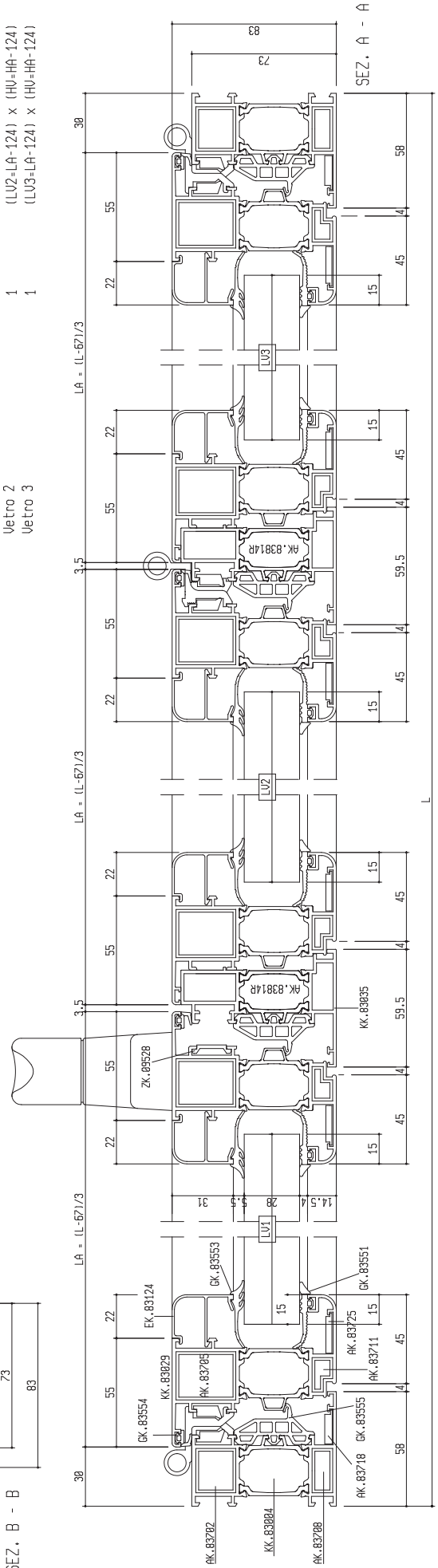

SEZ. B - B

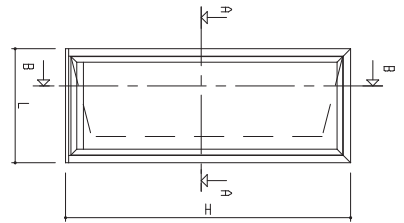
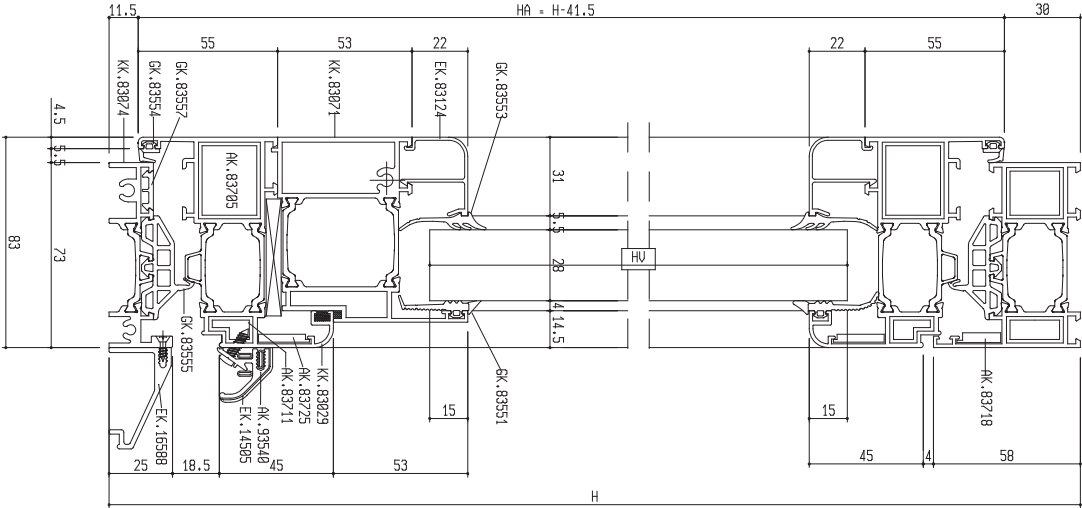

Prospetto visto dall'esterno

Peso indicativo ALLUMINIO
 L..... x 9.356 = Kg..... +
 H..... x 7.210 = Kg..... =
 Peso totale = Kg.....

PROFILATI	CODICE	PEZZI	MISURE	TAGLIO
Traverso telaio "L"	KK.83804	1	L	45-45
Montante telaio "L"	KK.83804	1	DX+1 SX H	45-90
Traverso anta "Z"	KK.83829	2	L-60	45-45
Montante anta "Z"	KK.83829	2	H-41,5	45-45
Zoccolo	KK.83871	1	LA-101	90-90
Soglia	KK.83874	1	L-63	90-90
Profilo rinforzo soglia	EK.16588	1	L	90-90
Fermavetro	EK.83124	2	L-214	90-90
Fermavetro	EK.83124	2	H-248,5	90-90
Gocciolatoio	EK.14585	1	L-138	90-90
Astina	ZK.09528	1		

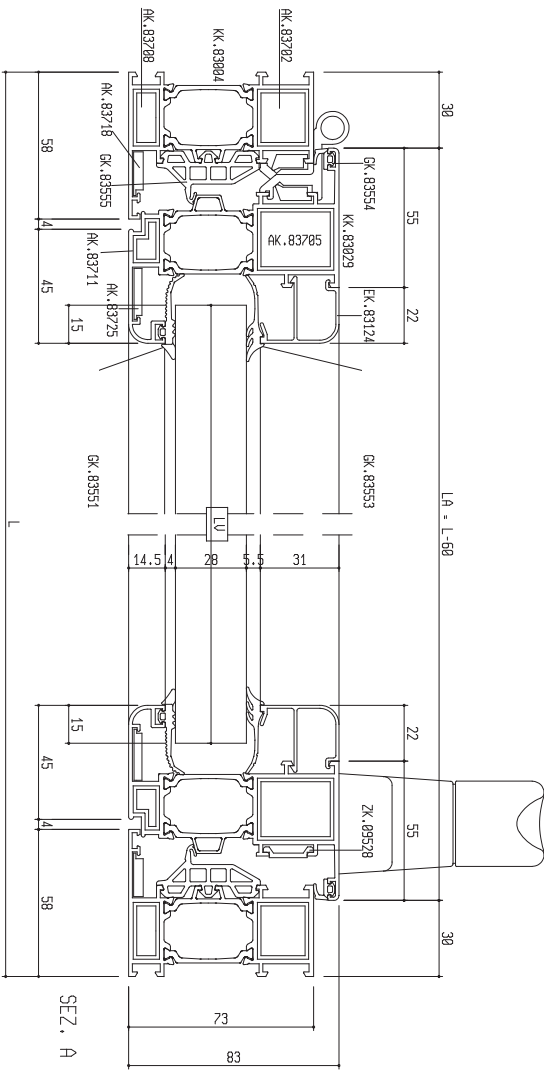

SEZ. A - A

GUARNIZIONI	CODICE	PEZZI
Battuta interna	KK.83554	2H+2L
Battuta centrale	KK.83555	2H+2L
Cingivetro esterna	KK.83551	2H+2L
Cingivetro interna	KK.83553	2H+2L
Guarnizione filo camera	KK.83557	L
ACCESSORI PERSONALIZZATI	CODICE	PEZZI
Squadretta interna telaio	KK.83702	2
Squadretta interna anta	KK.83705	4
Squadretta esterna telaio	KK.83708	2
Squadretta esterna anta	KK.83711	4
Squadretta allineamento telaio	KK.83718	2
Squadretta allineamento anta	KK.83725	4
Angolo pressofuso fermavetro	KK.93559	4
Spessore vetro	KK.83804	4
Angolo preformato	KK.83556	4
Coppia tappi gocciolatoio	KK.93540	1
Regolo distanziatore	KK.93813	in base alle dimensioni
ACCESSORI COMMERCIALI	CODICE	PEZZI
ACCESSORI COMMERCIALI A CAMERA EUROPEA DI FORNITORI QUALIFICATI		
DISTINTIVA VETRI	PEZZI	MISURE L x H
Vetro	1	(LV=LA-124) x (HV=HA-177)

GUARNIZIONI	CODICE	PEZZI
Battuta interna	GK.83554	3H+2L
Battuta centrale	GK.83555	3H+2L
Cingivetro esterna	GK.83551	4H+4L
Cingivetro interna	GK.83553	4H+4L
Guarnizione filo camera	GK.83557	L
ACCESSORI PERSONALIZZATI	CODICE	PEZZI
Squadretta interna telaio	AK.83702	2
Squadretta interna anta	AK.83705	8
Squadretta esterna telaio	AK.83708	2
Squadretta esterna anta	AK.83711	8
Squadretta allineamento telaio	AK.83718	4
Squadretta allineamento anta	AK.83725	8
* Coppia tappi battuta centrale	AK.83814R	1
Cavalloetto interno	AK.83717	2
Cavalloetto interno	AK.83721	8
Cavalloetto esterno	AK.83722	8
Angolo pressofuso fermavetro	AK.93559	16
Spessore vetro	AK.83804	16
Angolo preformato	GK.83556	4
Regolo distanziatore	AK.93813	in base alle dimensioni

Prospetto visto dall'esterno

Peso indicativo ALLUMINIO
 L..... x 12.611 = Kg..... +
 H..... x 11.557 = Kg..... =
 Peso totale = Kg.....

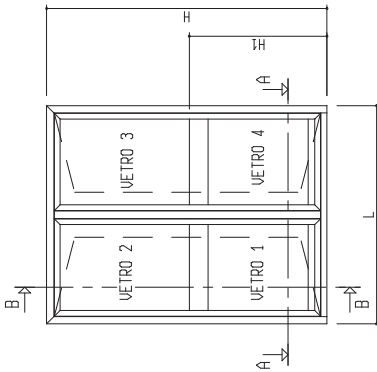

PROFILATI	CODICE	PEZZI	MISURE	TAGLIO
Traverso telaio "L"	KK.83804	1	L	45-45
Montante telaio "L"	KK.83804	1	DX+1 SX	45-90
Traverso anta "2"	KK.83829	4	(L-63,5)/2	45-45
Montante anta "2"	KK.83829	4	H-50	45-45
* Battuta centrale riportata	KK.83835	1	H-120	90-90 *
Zoccolo	KK.83871	2	LA-101	90-90
Fascia	KK.83819	2	LA-101	90-90
Soglia	KK.83801	1	L-63	90-90
Fermavetro	EK.83124	8	LA-154	90-90
Fermavetro	EK.83124	4	H1-300	90-90
Fermavetro	EK.83124	4	H-H1-107	90-90
Astina	ZK.09528			

* SOLUZIONE ALTERNATIVA CON TAPPI AK.83814M (H-122) MISURE TAGLIO 90-90

ACCESSORI COMMERCIALI	CODICE	PEZZI	MISURE L x H
Vetro 1		1	(LV1=LA-124) x (HV1=H1-270)
Vetro 2		1	(LV2=LA-124) x (HV2=H1-77)
Vetro 3		1	(LV3=LA-124) x (HV3=H1-77)
Vetro 4		1	(LV4=LA-124) x (HV4=H1-270)

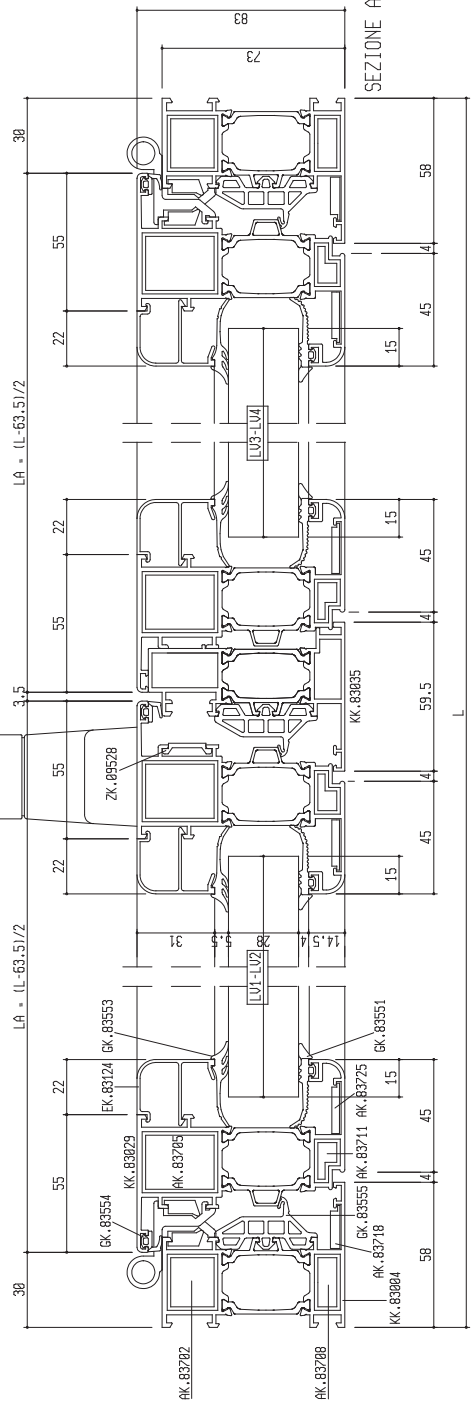
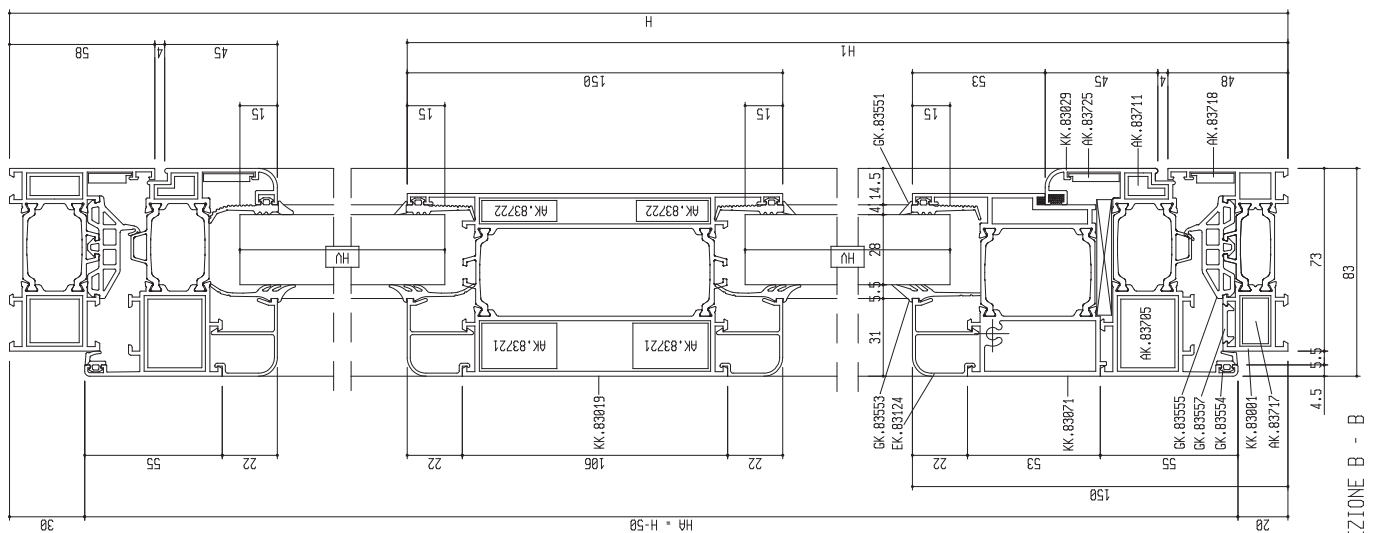

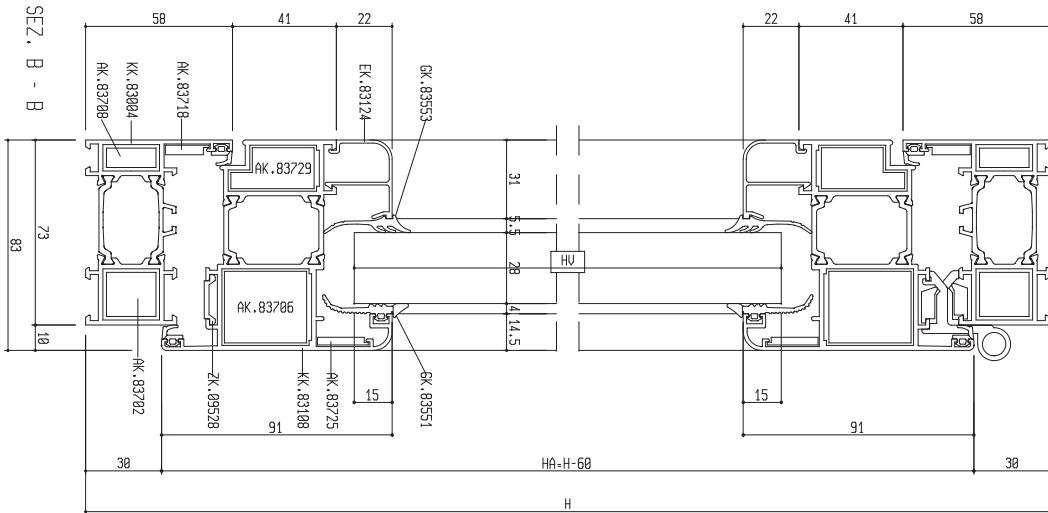

Prospetto visto dall'esterno

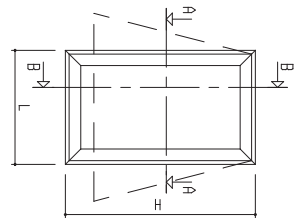

Peso indicativo ALLUMINIO
 L..... x 7,838 = Kg..... +
 H..... x 7,838 = Kg..... =
 Peso totale = Kg.....

PROFILATI	CODICE	PEZZI	MISURE	TAGLIO
Traverso telaio "L"	KK.83084	2	L	45-45
Montante telaio "L"	KK.83084	2	H	45-45
Traverso anta "Z"	KK.83108	2	L-60	45-45
Montante anta "Z"	KK.83108	2	H-60	45-45
Fermavetro	EK.83124	2	L-242	90-90
Fermavetro	EK.83124	2	H-242	90-90
Astina	ZK.09528			

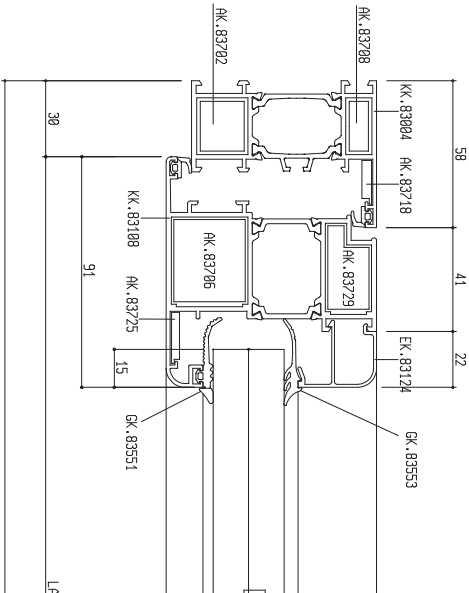

SEZ. A - A

GIARNIZIONI	CODICE	PEZZI
Battuta interna	GK.83554	2H+2L
Cingivetro esterna	GK.83551	2H+2L
Cingivetro interna	GK.83553	2H+2L
ACCESSORI PERSONALIZZATI	CODICE	PEZZI
Squadrella interna telaio	AK.83782	4
Squadrella interna anta	AK.83786	4
Squadrella esterna telaio	AK.83788	4
Squadrella esterna anta	AK.83729	4
Squadrella allineamento telaio	AK.83718	4
Squadrella allineamento anta	AK.83725	4
Angolo pressofuso fermavetro	AK.93559	4
Spessore vetro	AK.83884	4
Regolo distanziatore	AK.93813	4

In base alle dimensioni

ACCESSORI COMMERCIALI	CODICE	PEZZI
ACCESSORI COMMERCIALI A CAMERA EUROPEA DI FORNITORI QUALIFICATI		
DISTINTIVA VETRI	PEZZI	MISURE L x H
Vetro	1	(L=LA-152) x (H=HA-152)

LAVORAZIONI

- *Lavorazioni principali (Schede SL)*

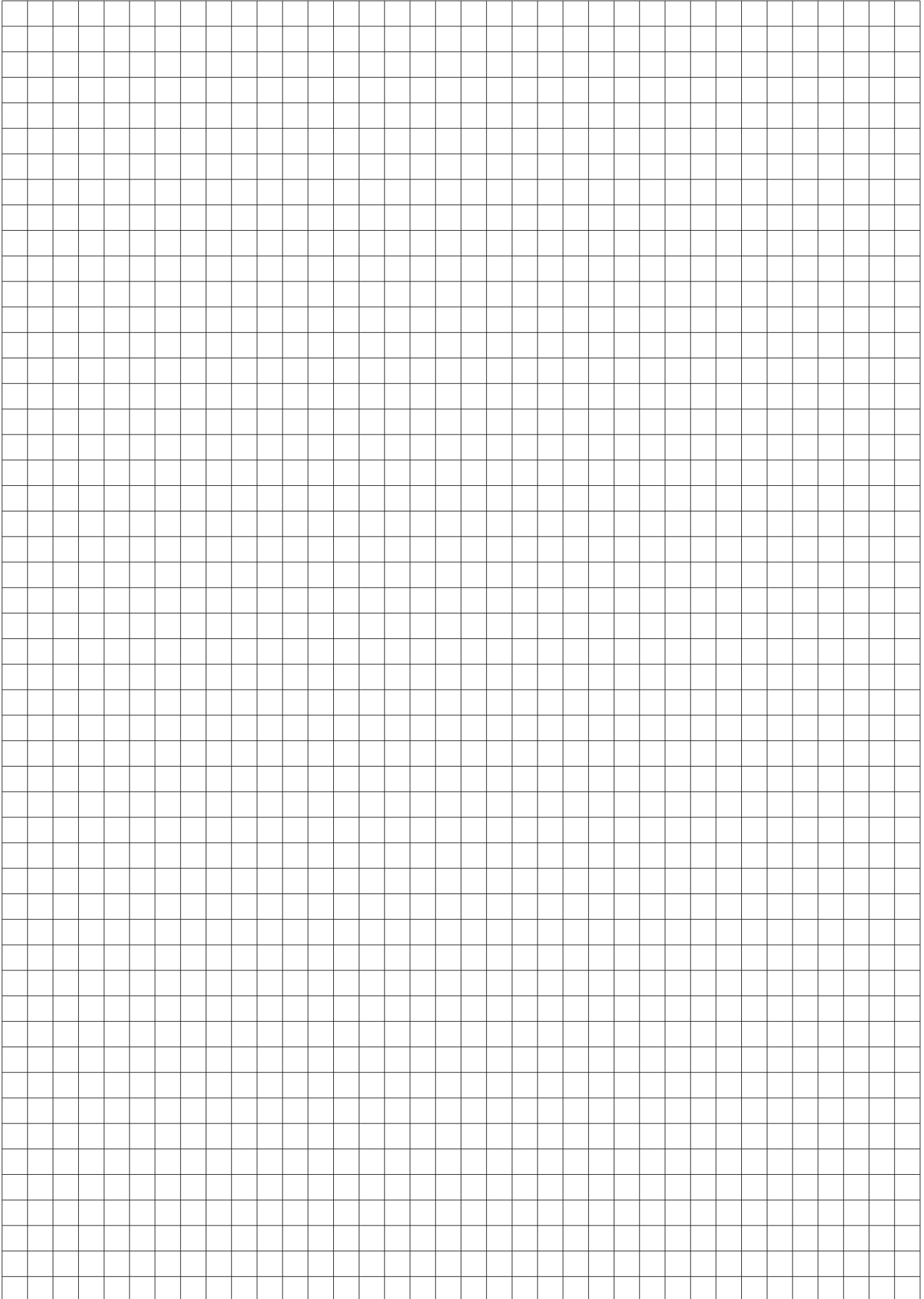

Lavorazioni su TELAI PICCOLI per SQUADRETTE AK.83701 E AK.83707

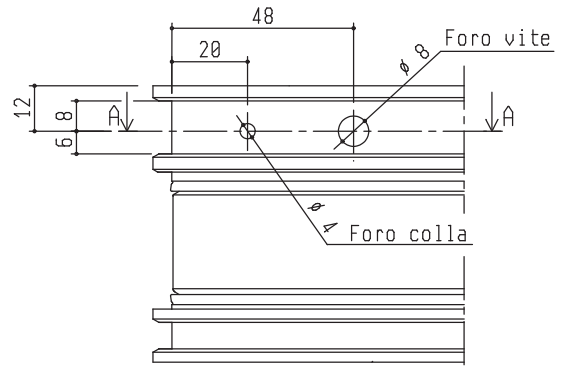
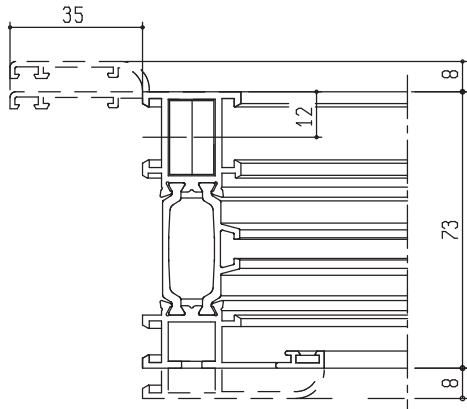

Lavorazione per squadretta interna AK.83701

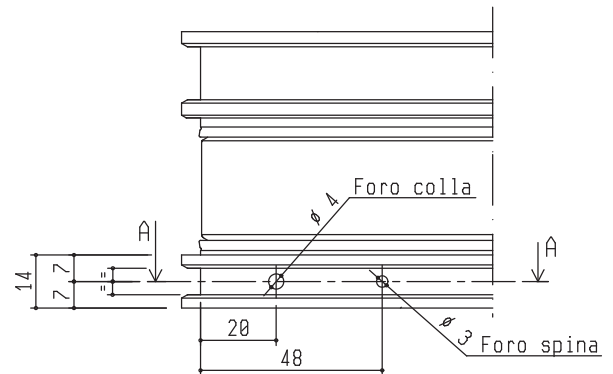
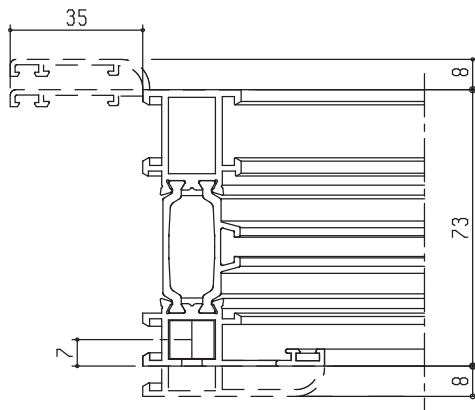
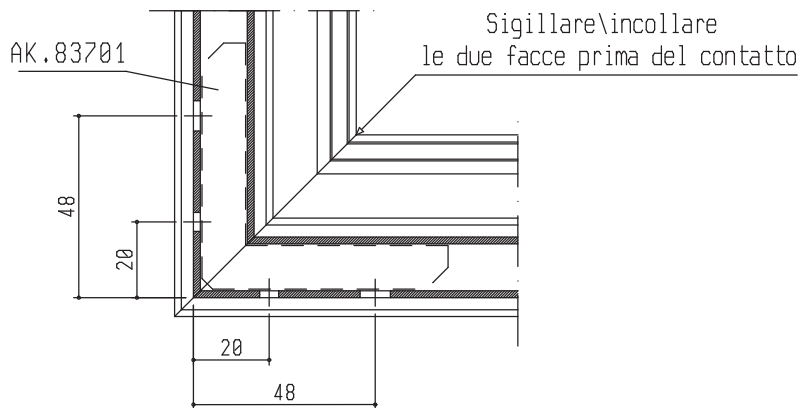

Lavorazione per squadretta esterna AK.83707

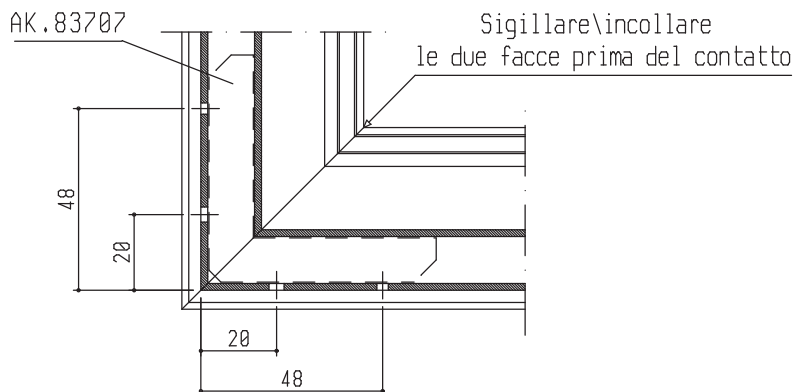

NB: SCHEDA LAVORAZIONI VALIDA PER TUTTI I TELAI FISSI PICCOLI (telai L-Z-T, soluzioni complanari, complanari/sormonto, sormonto/sormonto ecc.)

Lavorazioni su TELAI MEDI per SQUADRETTE AK.83702 E AK.83708

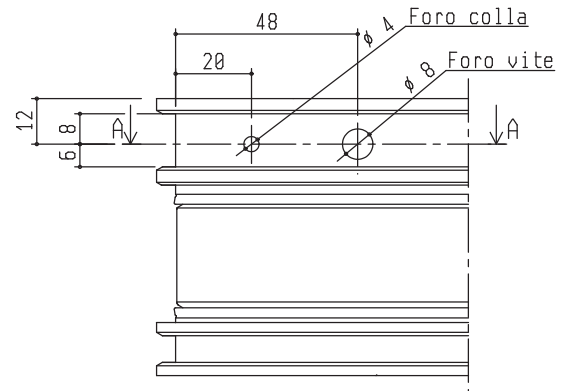
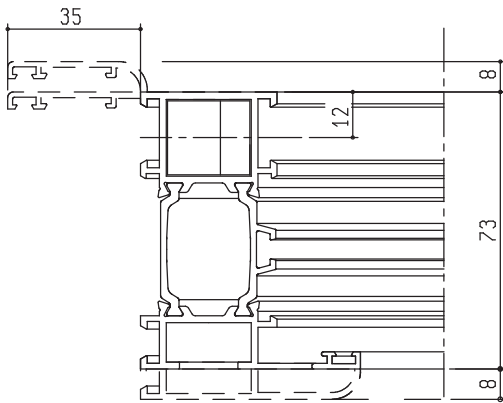

Lavorazione per squadretta interna AK.83702

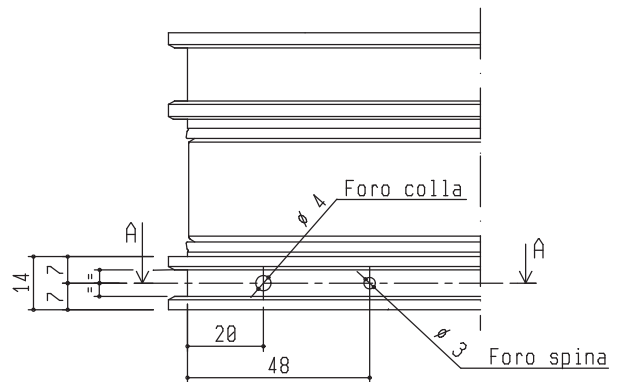
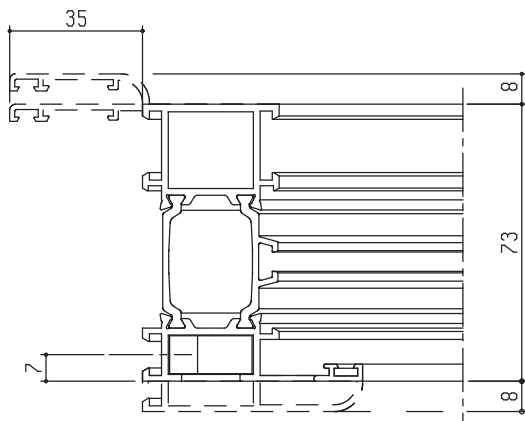
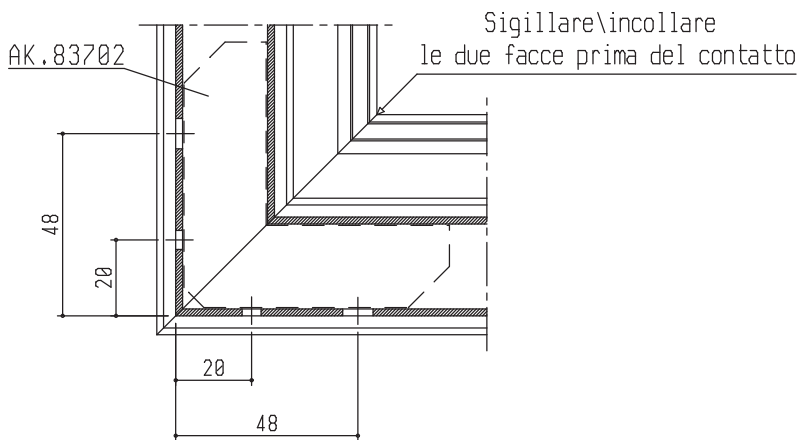

Lavorazione per squadretta esterna AK.83708

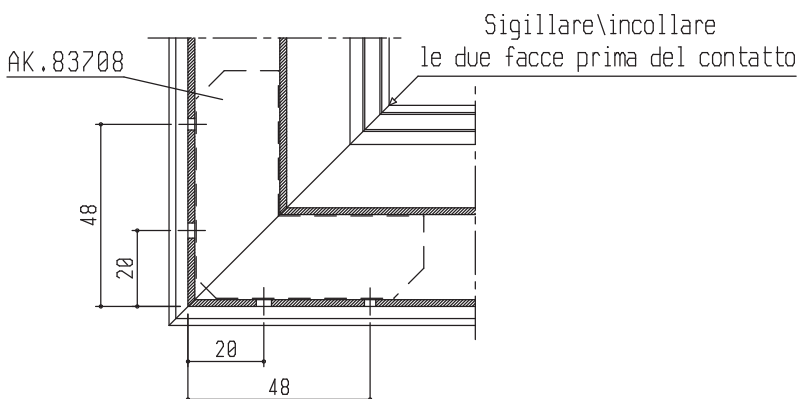

NB: SCHEDA LAVORAZIONI VALIDA PER TUTTI I TELAI FISSI MEDI
(telai L-Z-T, soluzioni complanari, complanari/sormonto, sormonto/sormonto ecc.)

Lavorazioni su TELAI GRANDI per SQUADRETTE AK.83703 E AK.83709

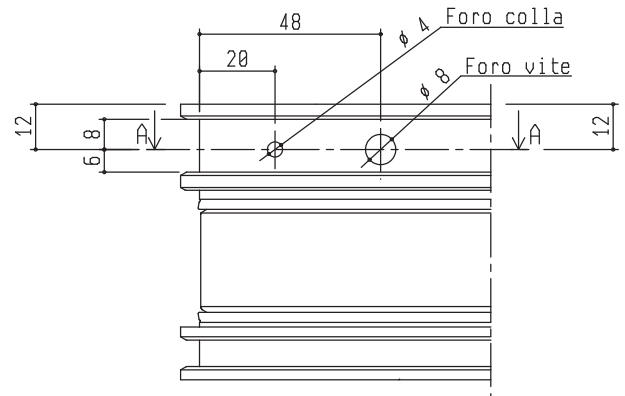
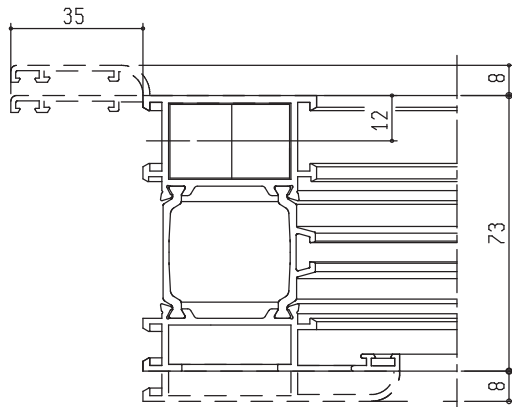

Lavorazione per squadretta interna AK.83703

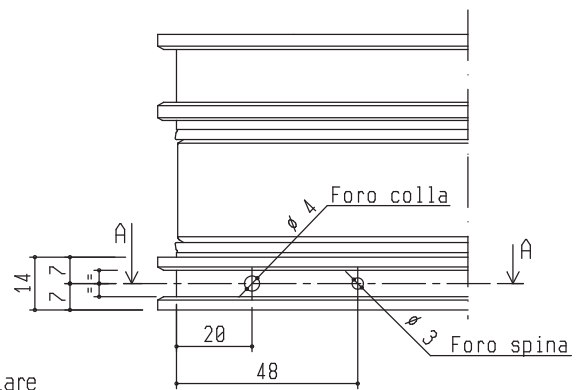
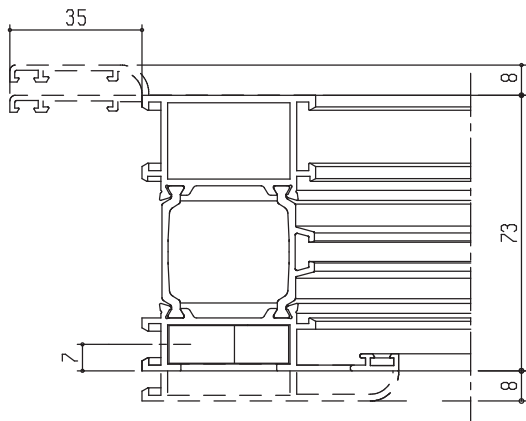
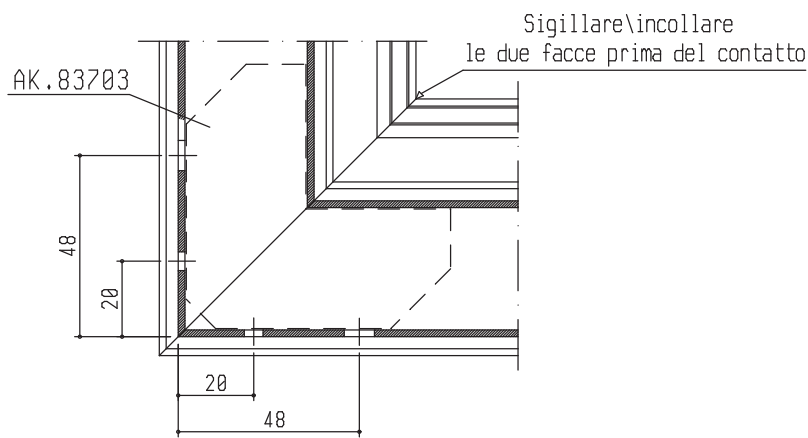

Lavorazione per squadretta esterna AK.83709

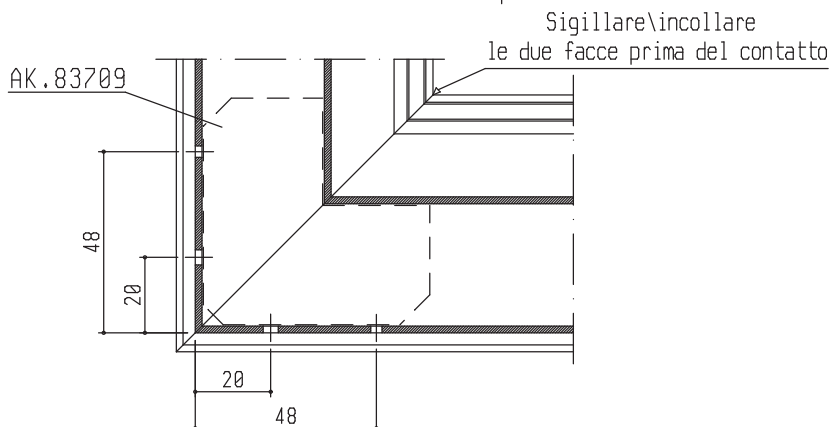

NB: SCHEDA LAVORAZIONI VALIDA PER TUTTI I TELAI FISSI GRANDI (telai L-Z-T, soluzioni complanari, complanari/sormonto, sormonto/sormonto ecc.)

Lavorazioni su ANTE PICCOLE per SQUADRETTE AK.83704 E AK.83710

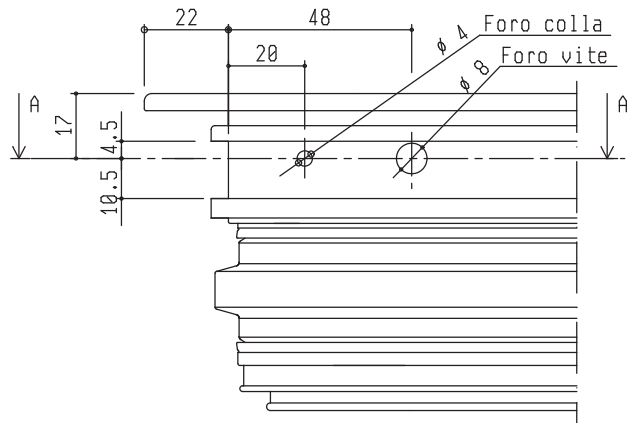
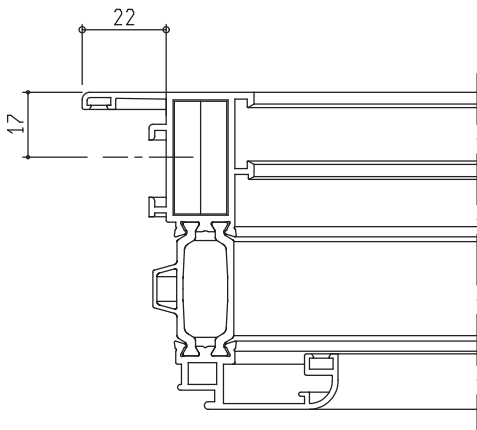

Lavorazione per squadretta interna AK.83704

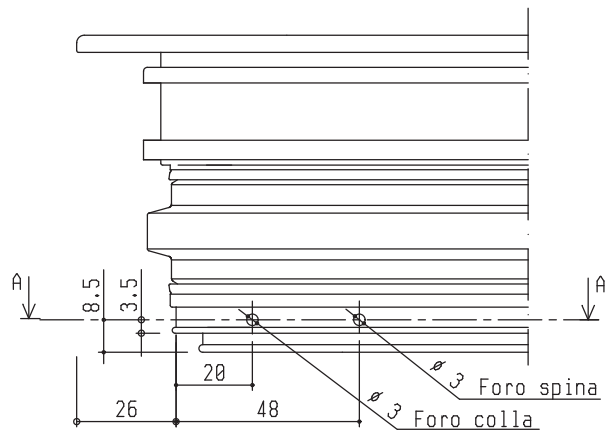
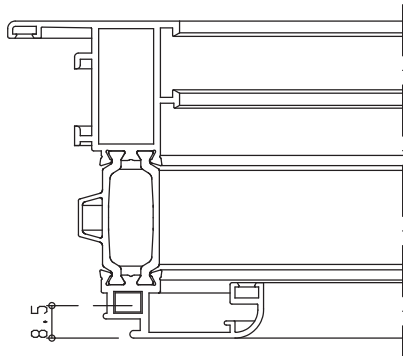
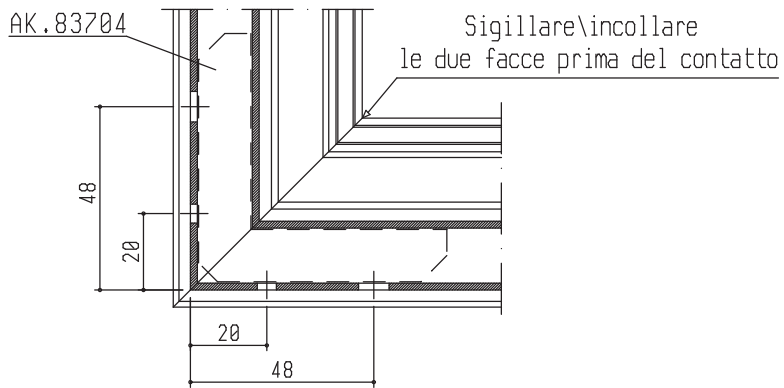

Lavorazione per squadretta esterna AK.83710

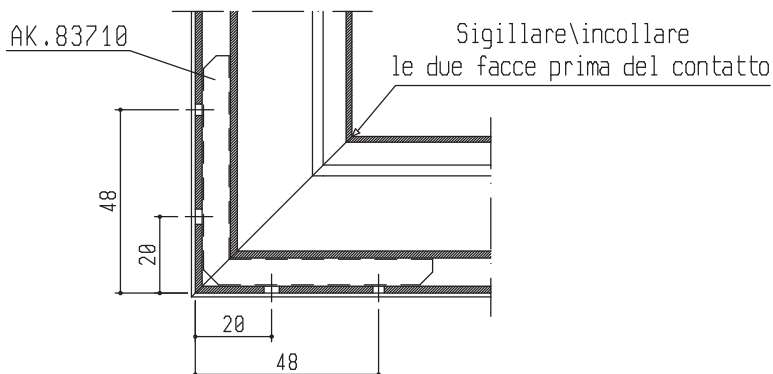

NB: SCHEDA LAVORAZIONI VALIDA PER TUTTE LE ANTE PICCOLE T-Z

Lavorazioni su ANTE MEDIE per SQUADRETTE AK.83705 E AK.83711

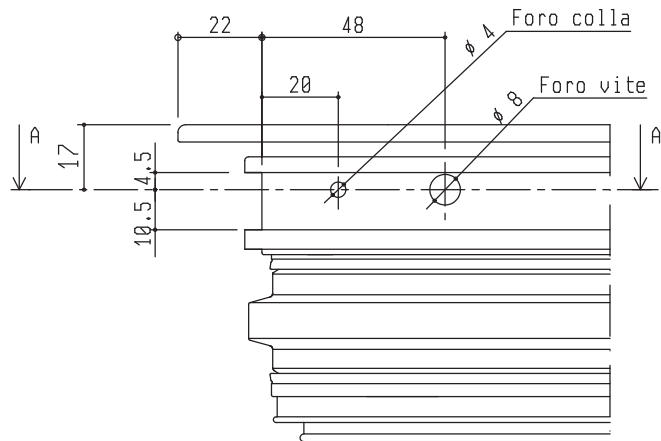
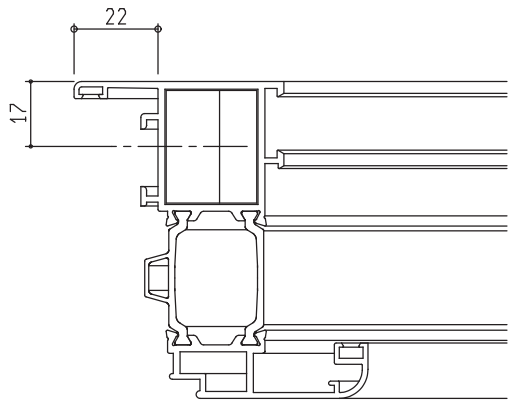

Lavorazione per squadretta esterna AK.83705

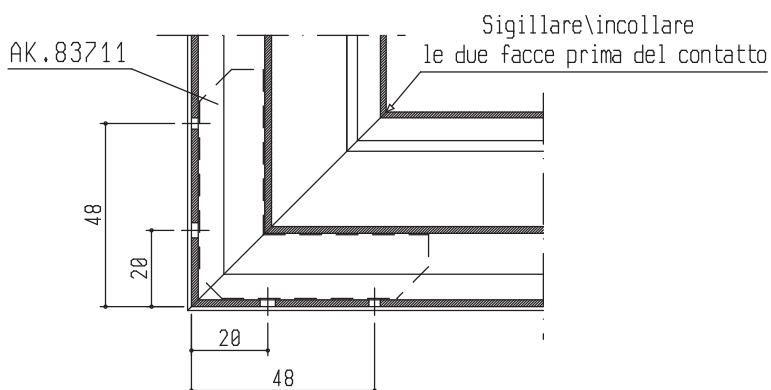
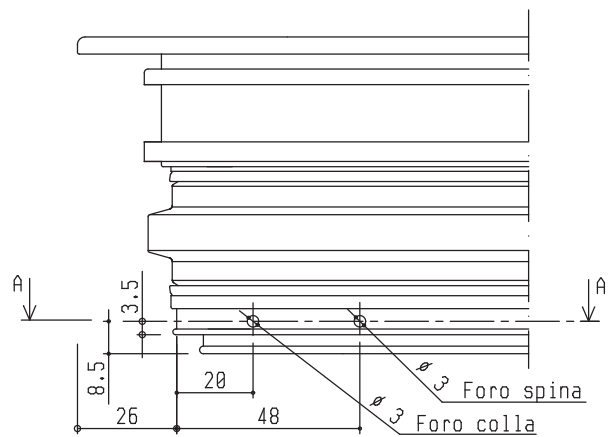
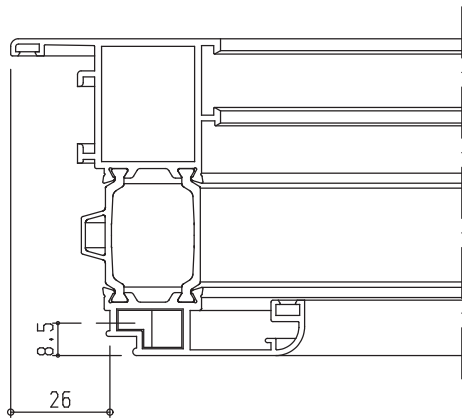
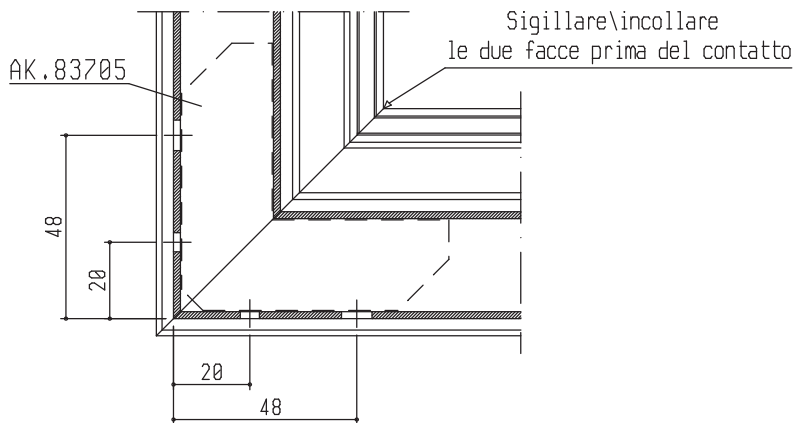

Lavorazione per squadretta esterna AK.83711

NB: SCHEDA LAVORAZIONI VALIDA PER TUTTE LE ANTE MEDIE T-Z

Lavorazioni su ANTE GRANDI per SQUADRETTE AK.83706 E AK.83712

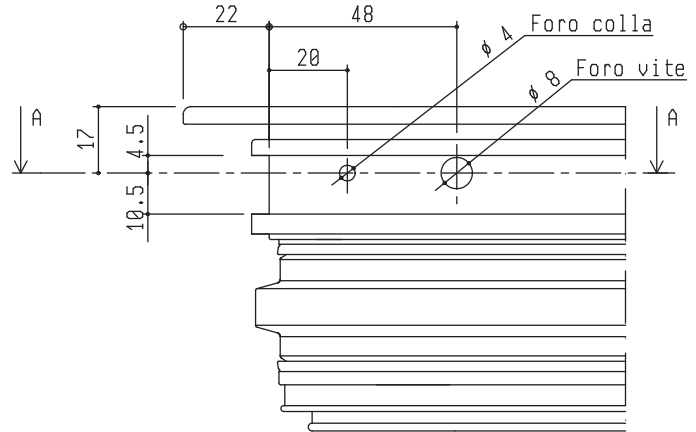
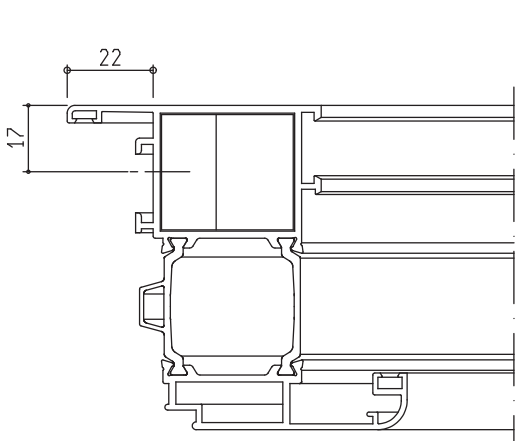

Lavorazione per squadretta interna AK.83706

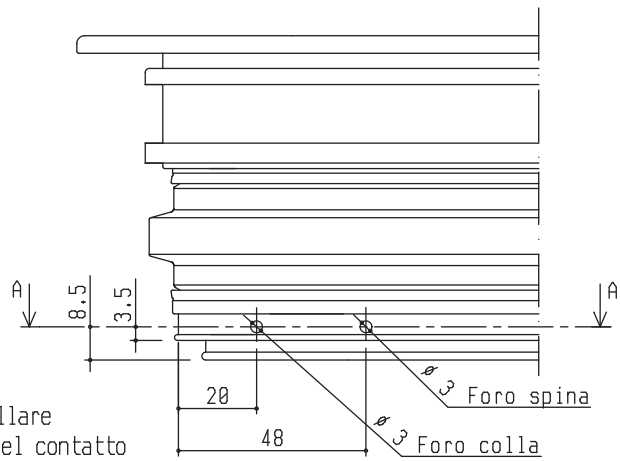
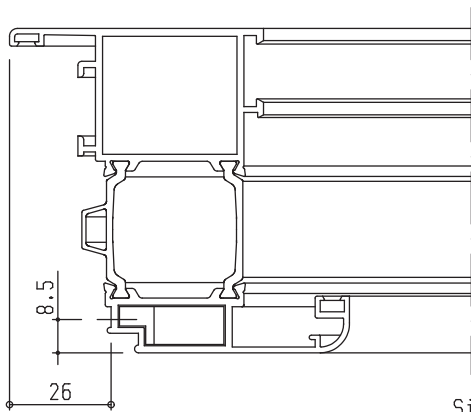
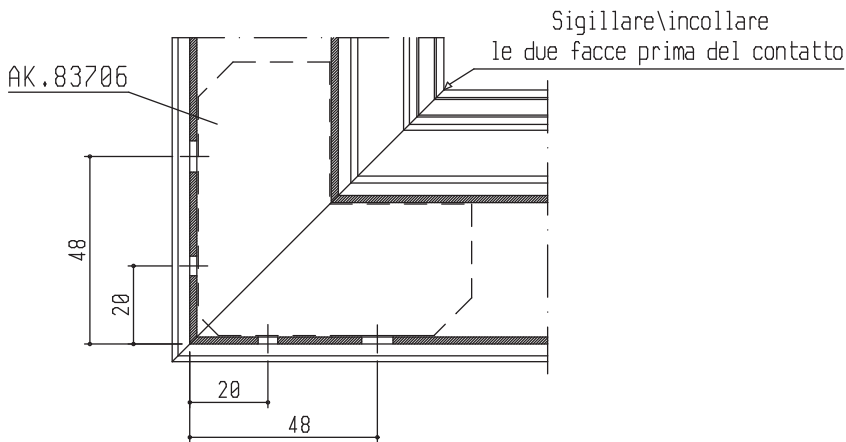

Lavorazione per squadretta esterna AK.83712

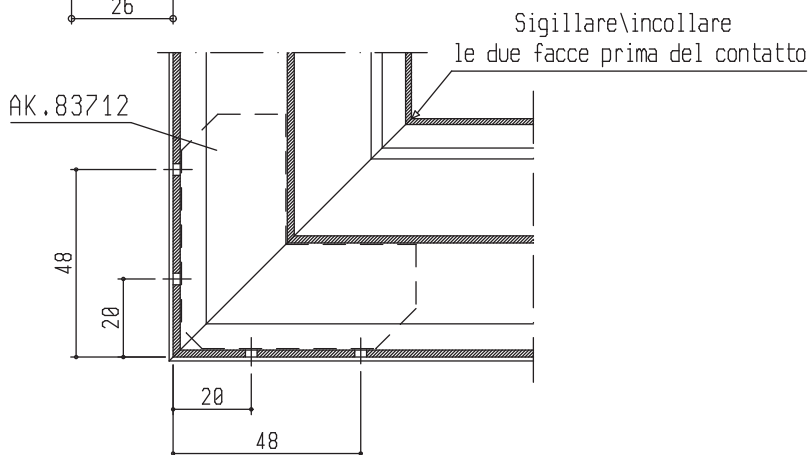

NB: SCHEDA LAVORAZIONI VALIDA PER TUTTE LE ANTE GRANDI T-Z

Lavorazioni su FASCIA da 26/70 mm KK.83010 su ante architettoniche

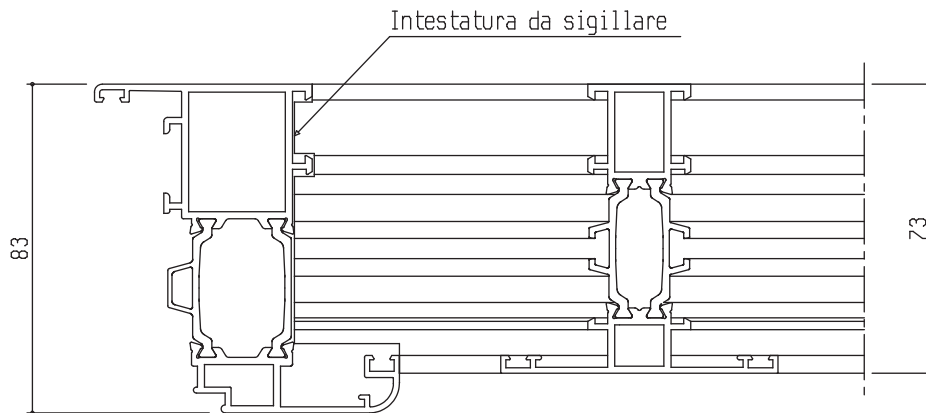

Lavorazioni e posizionamento cavallotti relativi

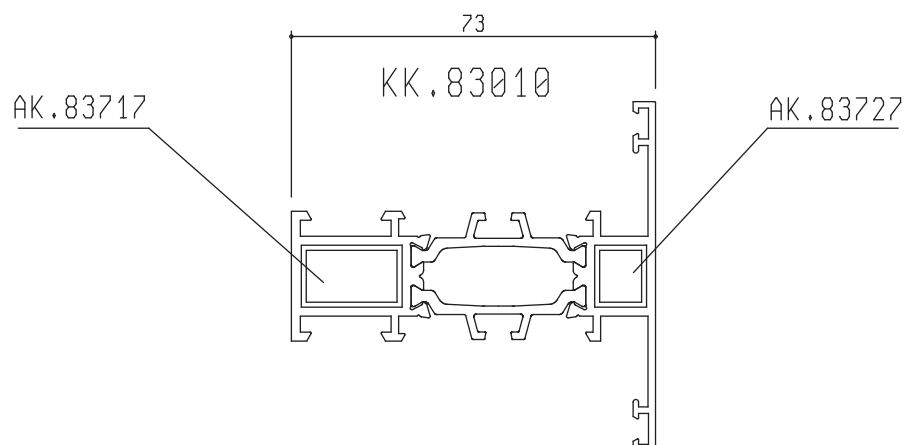
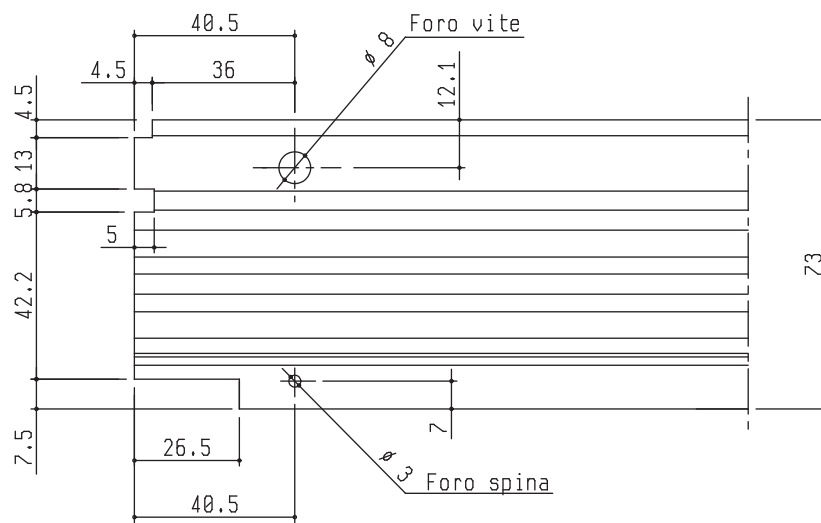

Lavorazione FASCE/ZOCCOLO su ante

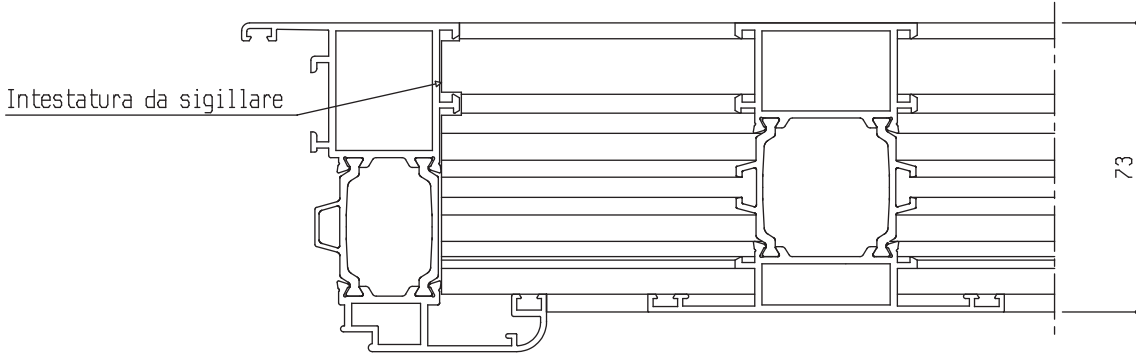

Lavorazioni e posizionamento cavallotti relativi

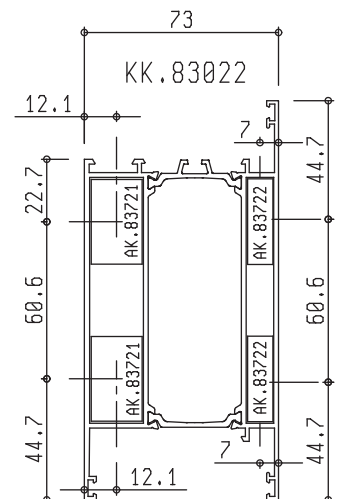
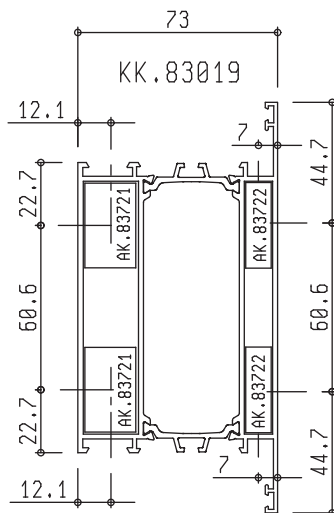
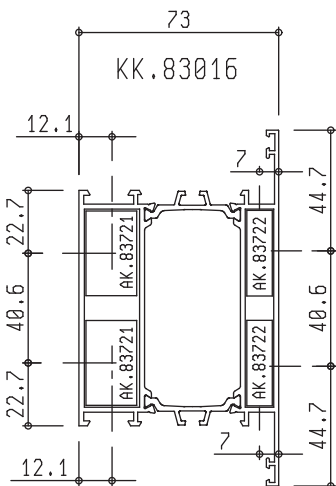
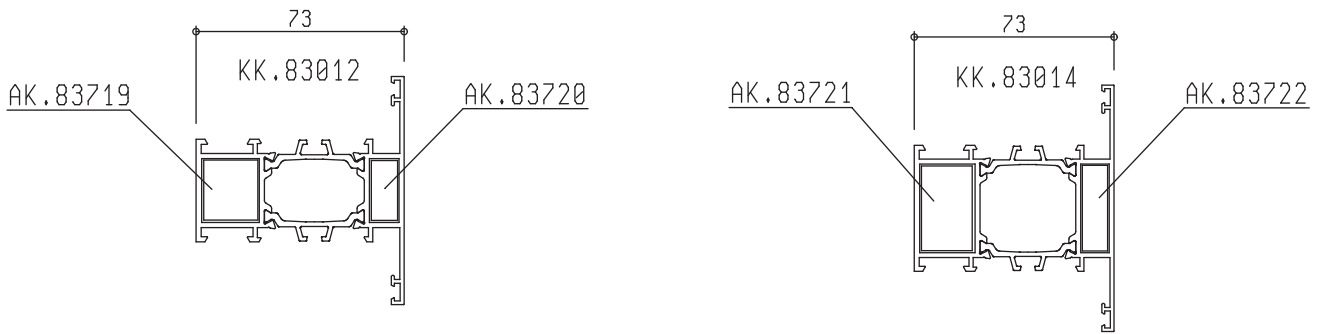
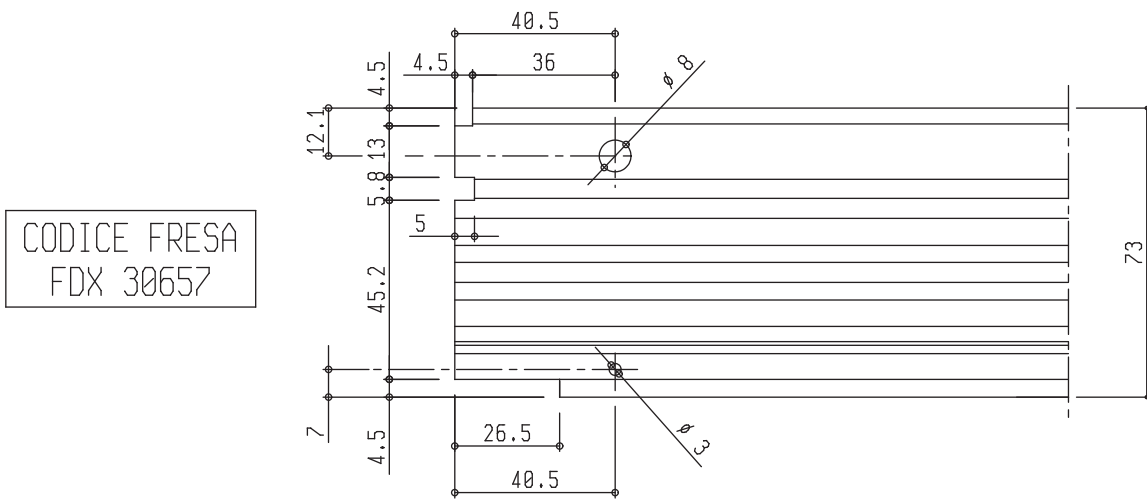

Lavorazione ZOCCOLO RIPORTATO su ante ARCHITETTONICHE

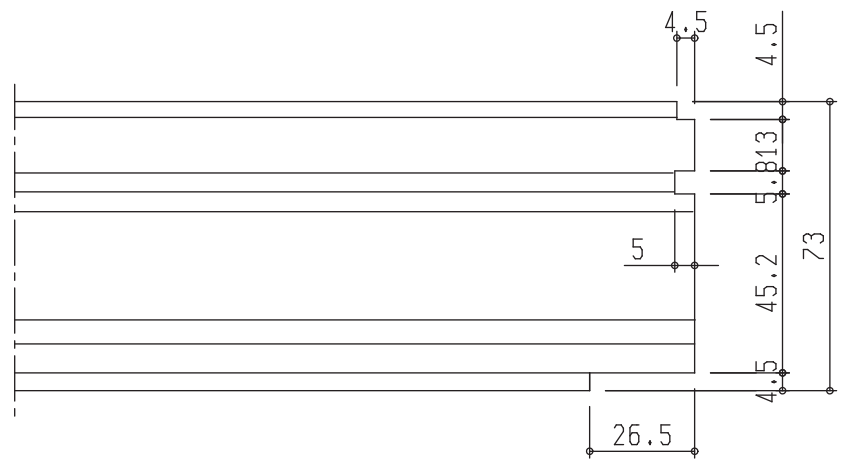
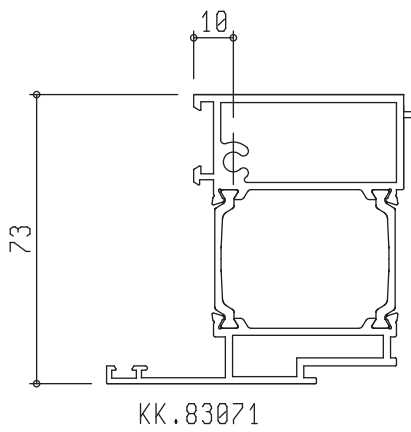
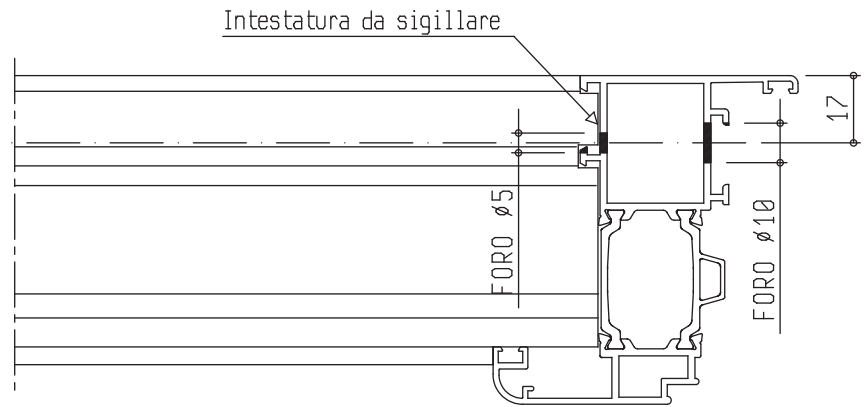
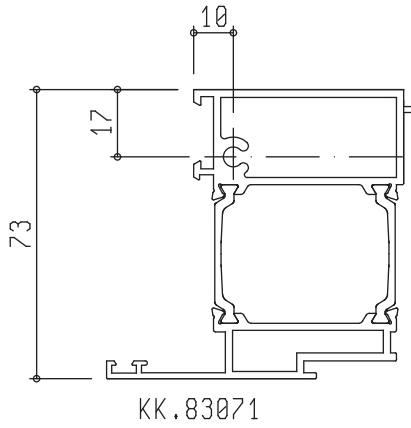

CODICE FRESA
FDX 30657



Sistemi

TGP TH73

DATA	SCHEDA
Maggio 2016	SL10

Lavorazione FASCE/ZOCCOLO SU ELEMENTI FISSI

SOLUZIONE CONSIGLIATA

SOLUZIONE ALTERNATIVA

NB: Non sono previsti tappi

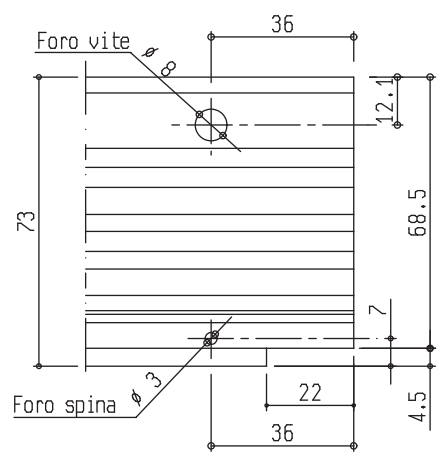
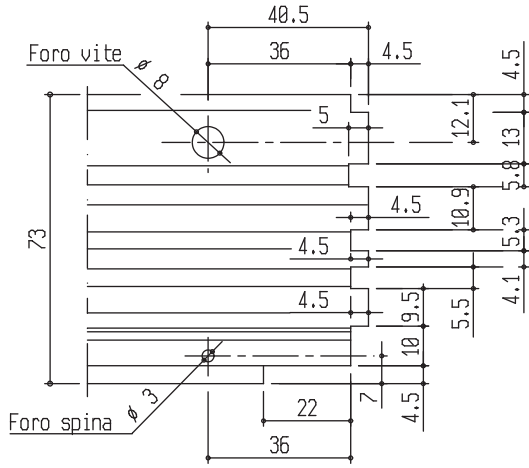
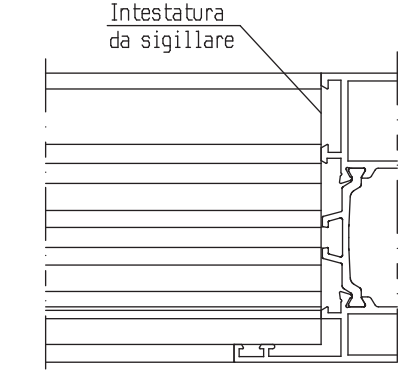
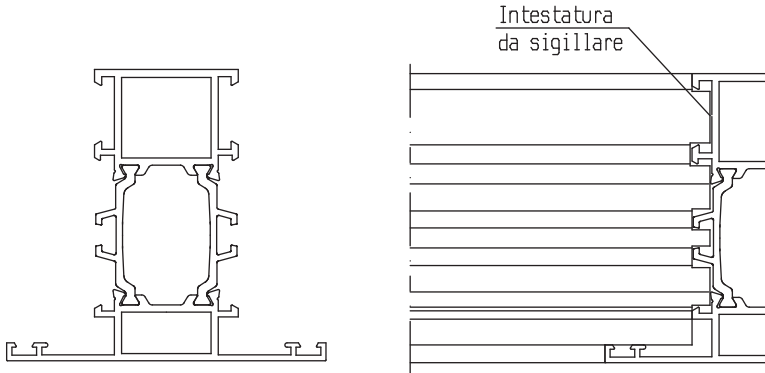

CODICE FRESA
FDX 30679

CODICE FRESA
FDX 30654

POSIZIONAMENTO CAVALLOTTI

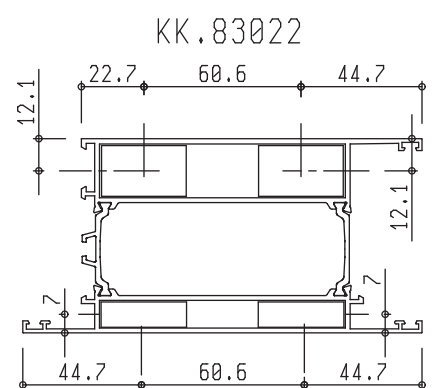
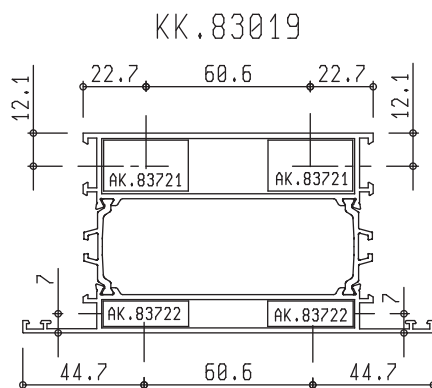
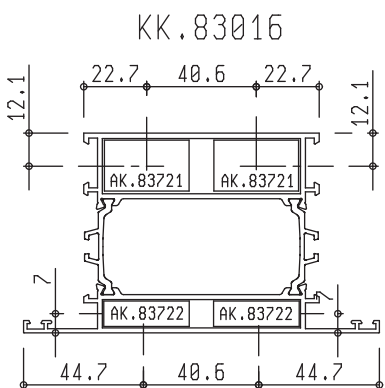
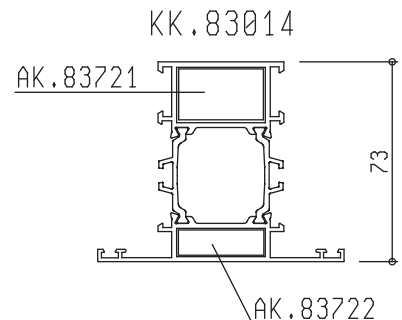
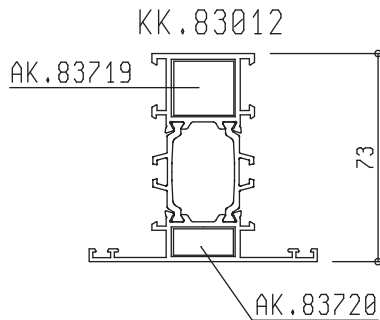
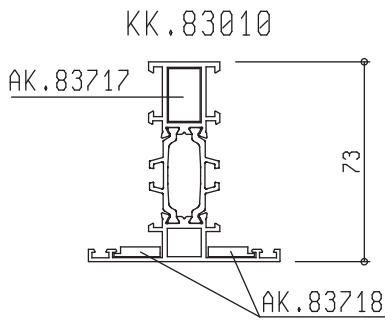

LAVORAZIONI PER SEZIONI CON SOGLIA RIBASSATA KK.83074
LAVORAZIONI SOGLIA RIBASSATA E TELAI FISSI

SOLUZIONE CONSIGLIATA

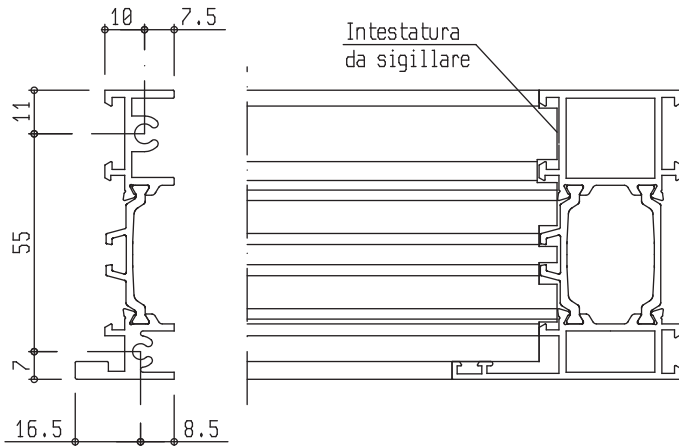

SOLUZIONE ALTERNATIVA

NB: Non sono previsti tappi

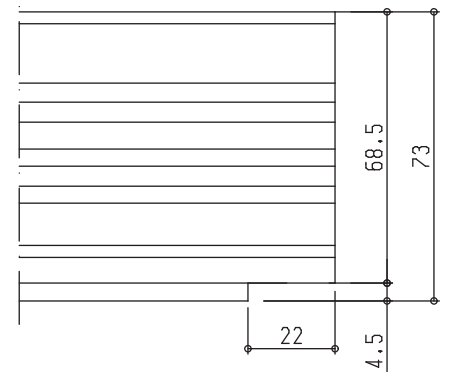
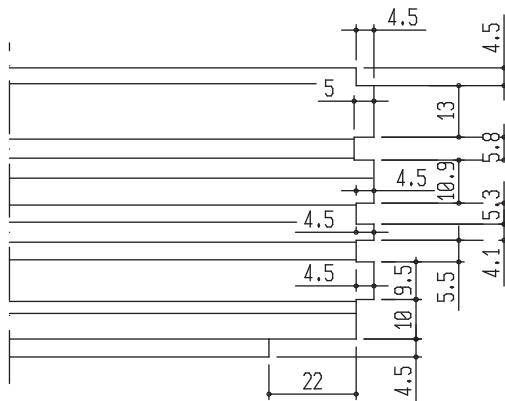
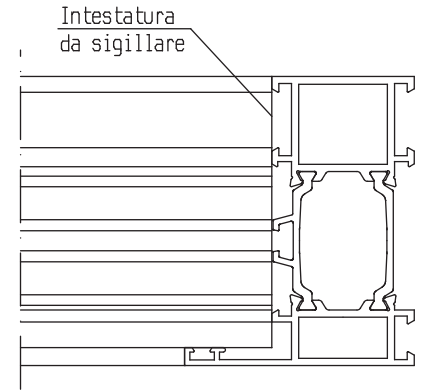

CODICE FRESA
FDX 30679

CODICE FRESA
FDX 30654

LAVORAZIONI TELAI FISSI

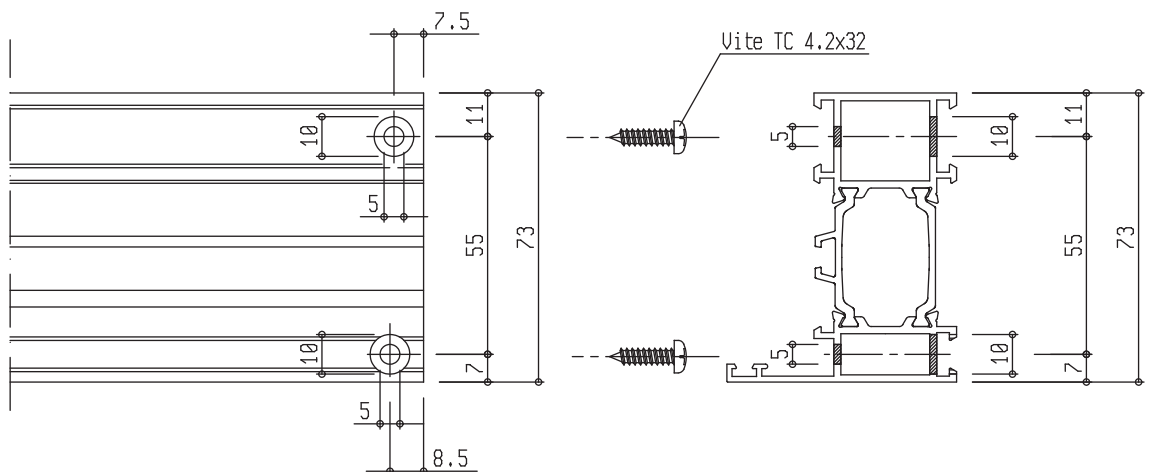

Lavorazioni su ANTA a SPORGERE KK.83108
per SQUADRETTE AK.83729 E AK.83706

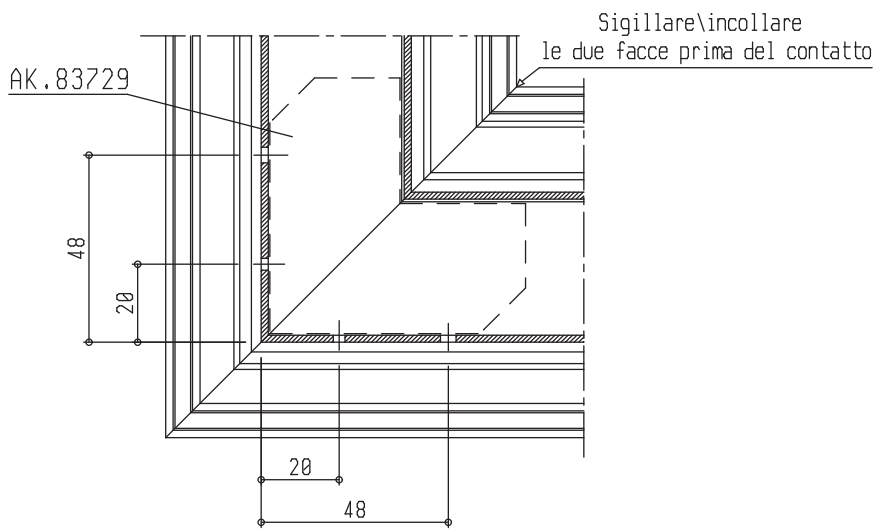
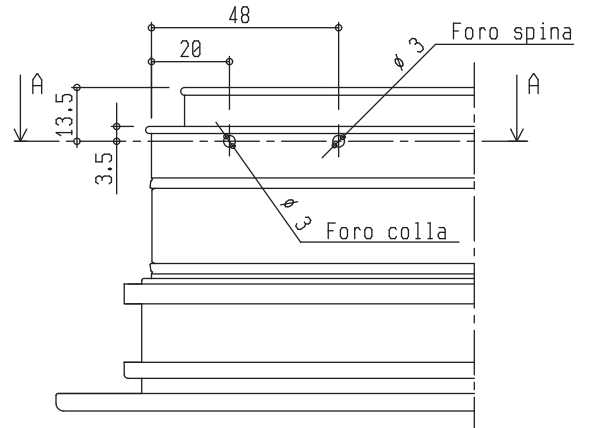
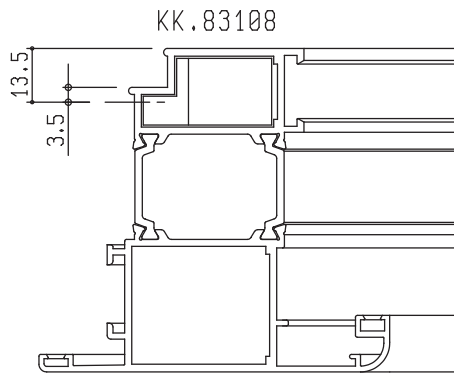

Lavorazione per squadretta interna AK.83729

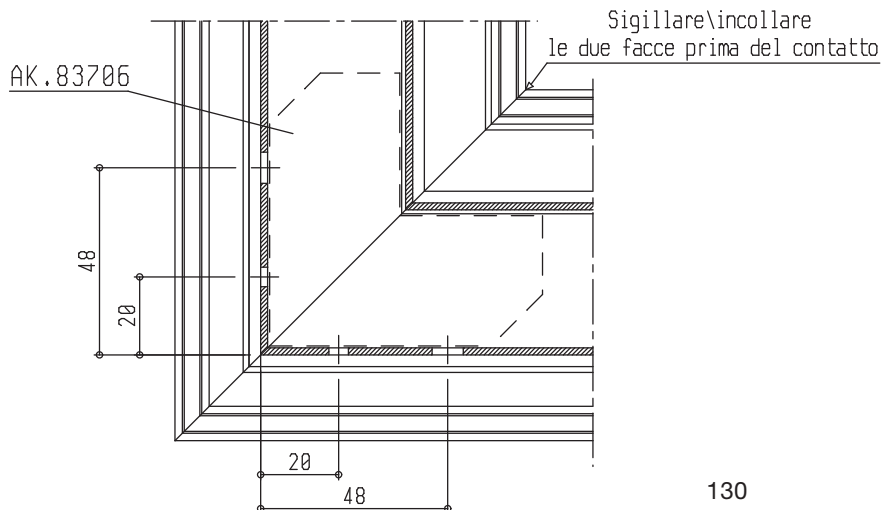
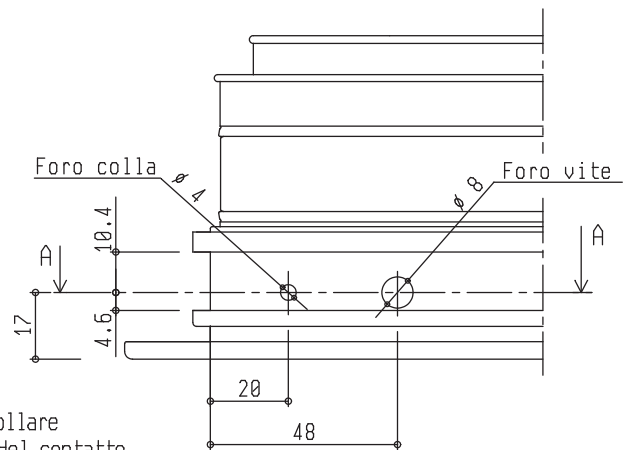
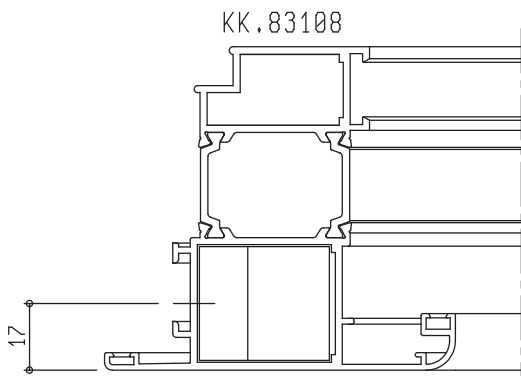

Lavorazione per squadretta esterna AK.83706

Lavorazioni su INVERSIONE DI BATTUTA per SPORGERE KK.83111
per SQUADRETTE AK.83701 E AK.83707

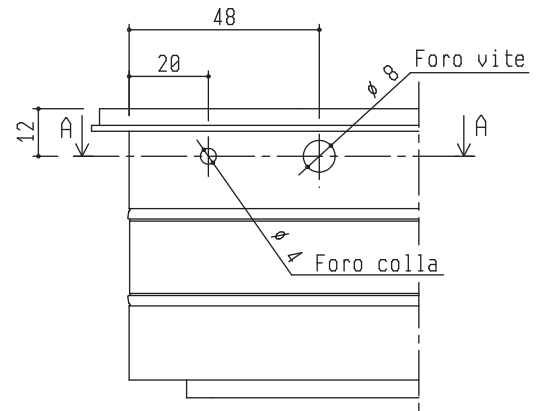
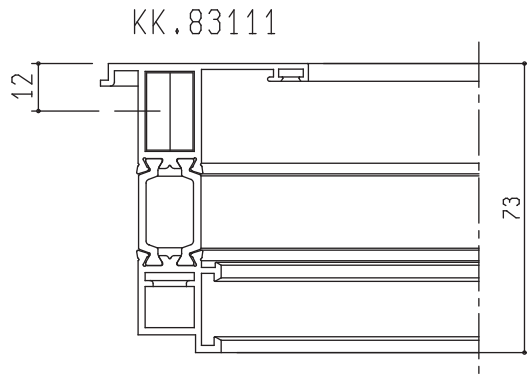

Lavorazione per squadretta
interna AK.83701

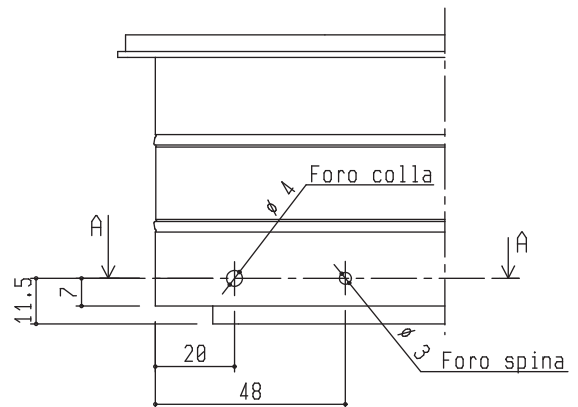
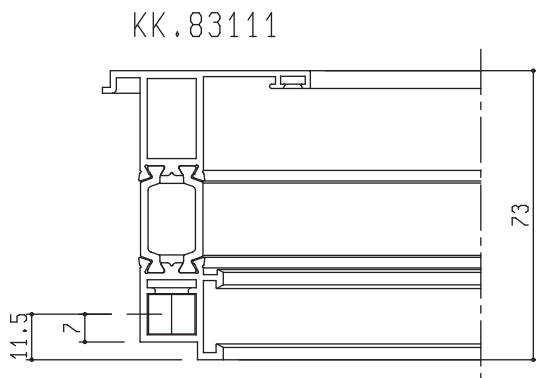
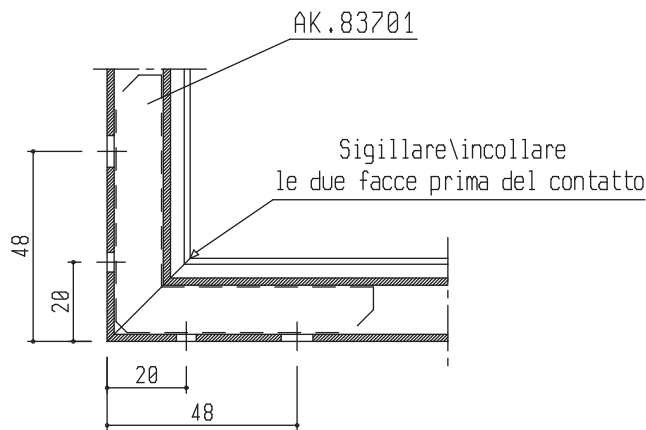

Lavorazione per squadretta
esterna AK.83707

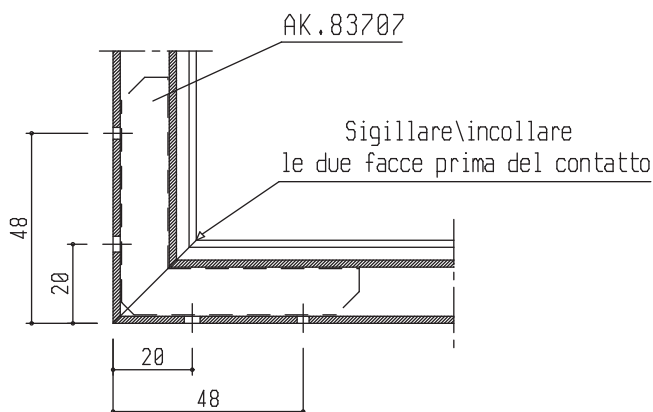

Lavorazioni per DISTANZIATORE AK.73802



TABELLA INDICATIVA PER POSIZIONAMENTO REGOLI

$A = da\ 100\ mm\ a\ 150\ mm$

$B = 500\ mm$

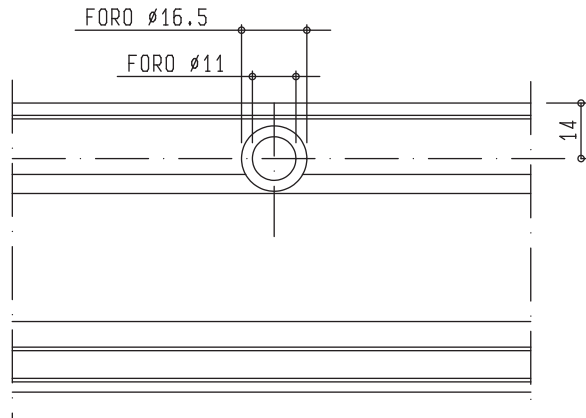
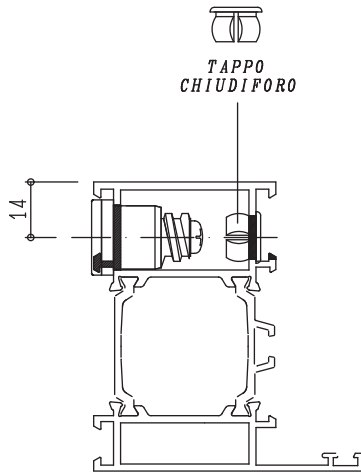
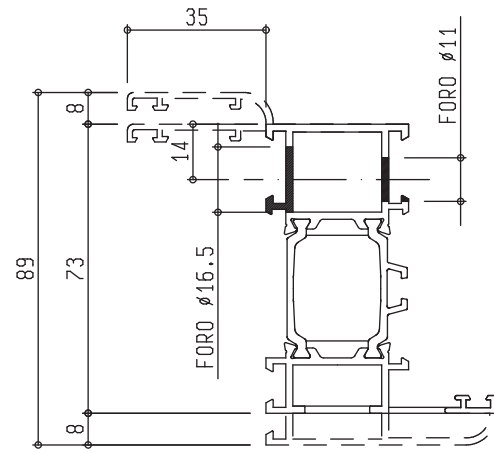
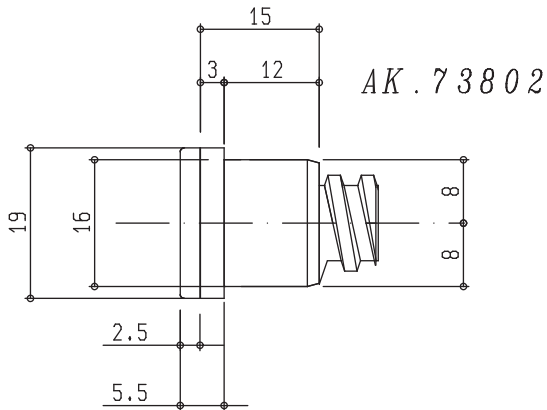
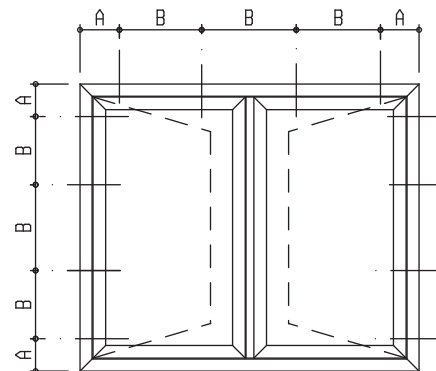
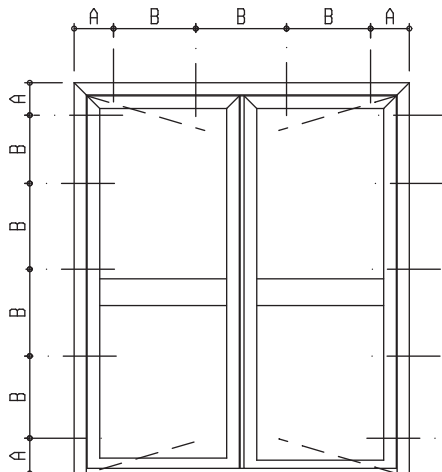

NB: SCHEDA LAVORAZIONI VALIDA PER TUTTI I TELAI FISSI
(telai L-Z-T, soluzioni complanari, complanari/sormonto, sormonto/sormonto ecc.)

Asola e fori per cremonese

DA ESEGUIRE CON PUNZONATRICE ZPX 14372 (Stazione 1A)

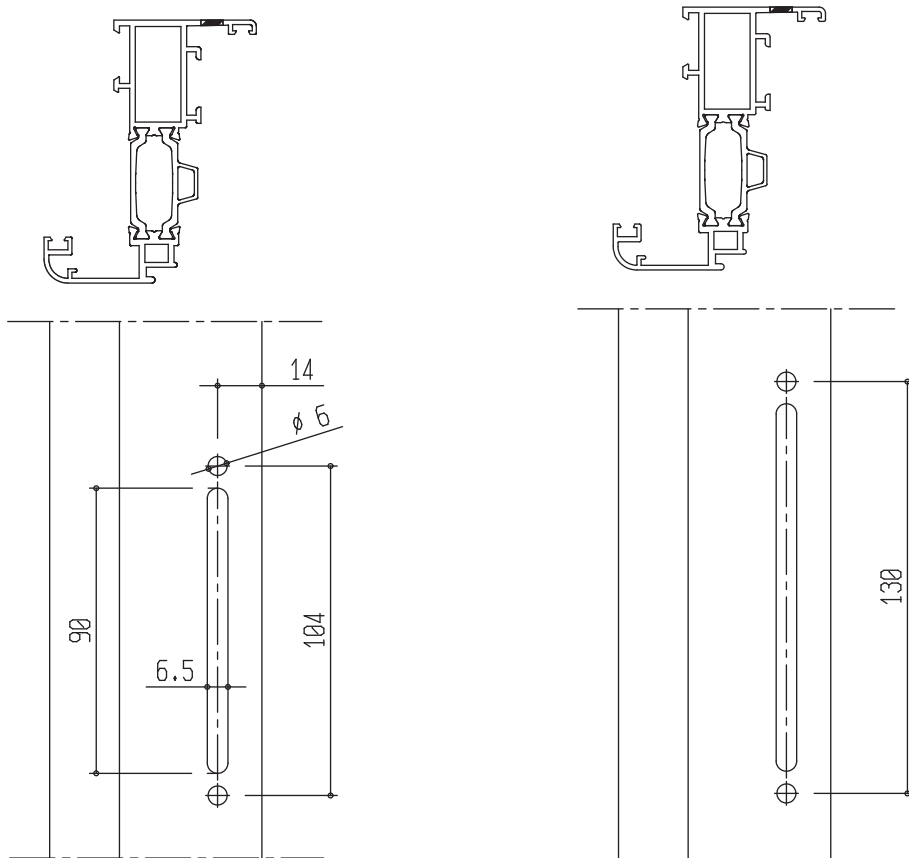

Lavorazione in 1 colpo

Lavorazione in 2 colpi

Foro su astina

DA ESEGUIRE CON PUNZONATRICE ZPX 14372 (Stazione 1B)



Spuntatura dentini passaggio astina

DA ESEGUIRE CON PUNZONATRICE ZPX 14372 (Stazione 2)

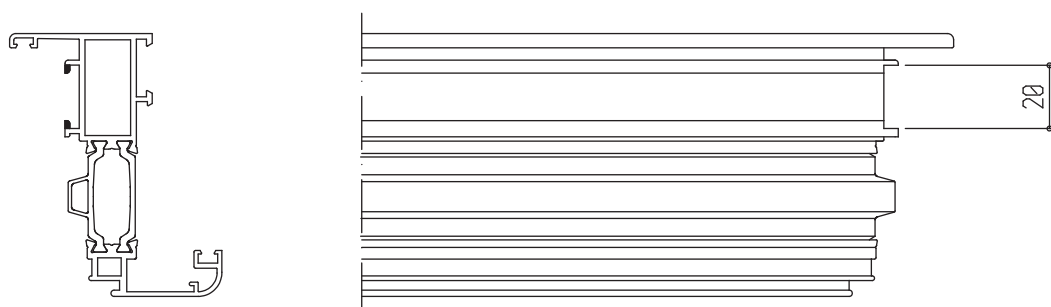

Asola drenaggio

DA ESEGUIRE CON PUNZONATRICE ZPX 14372 (Stazione 5)

TELAI COMPLANARI

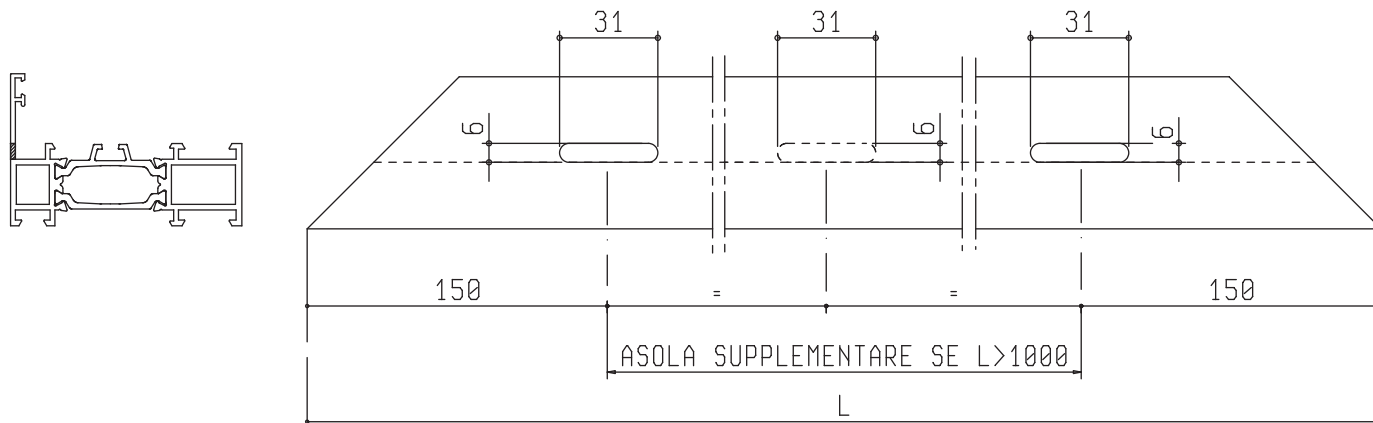

Asola areazione vetro lato vetro

DA ESEGUIRE CON PUNZONATRICE ZPX 14372 (Stazione 7)

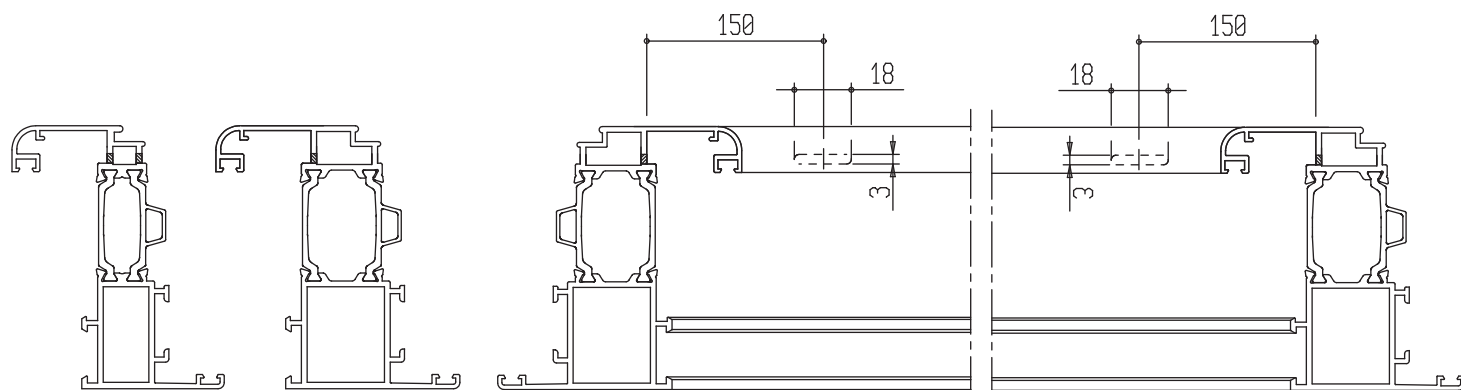

NB. Sulle ante PICCOLE
la lavorazione
sarà PASSANTE

Asola areazione vetro lato esterno

DA ESEGUIRE CON PUNZONATRICE ZPX 14372 (Stazione 8)

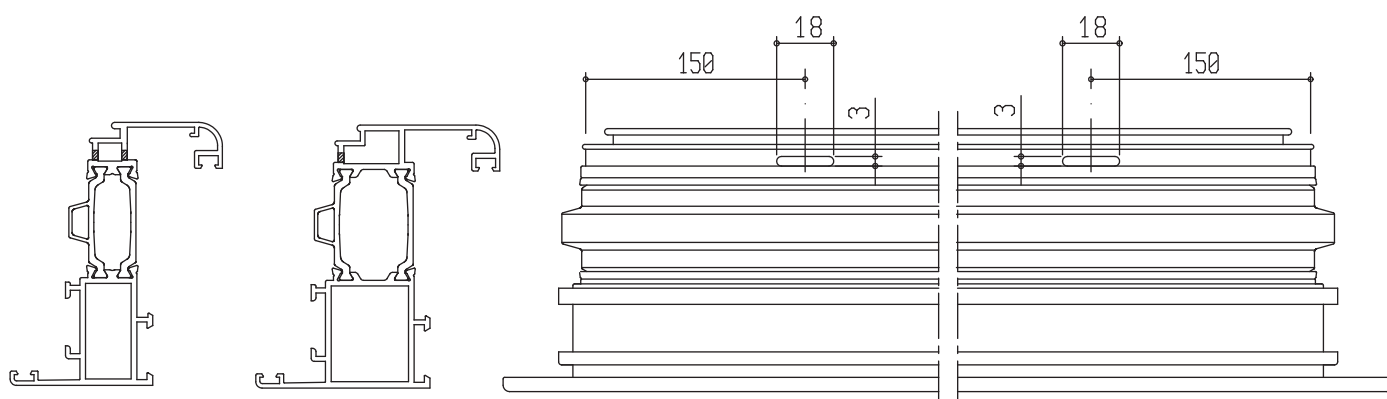

NB. Sulle ante PICCOLE
la lavorazione
sarà PASSANTE

